



Board of County Commissioners Agenda Request

7A

Agenda Item #

Requested Meeting Date: 4-14-26

Title of Item: MnDOT Intersection Control Evaluation (ICE) Reort

<input checked="" type="checkbox"/> REGULAR AGENDA <input type="checkbox"/> CONSENT AGENDA	Action Requested: <input type="checkbox"/> Approve/Deny Motion <input type="checkbox"/> Adopt Resolution (attach draft) <input type="checkbox"/> Hold Public Hearing <i>*provide copy of hearing notice that was published</i>	<input type="checkbox"/> Direction Requested <input checked="" type="checkbox"/> Discussion Item <input checked="" type="checkbox"/> Information Only
---	--	---

Submitted by: John Welle	Department: Highway Department
------------------------------------	--

Presenter (Name and Title): John Welle, Aitkin County Engineer	Estimated Time Needed: 15 minutes
--	---

Summary of Issue:

Over the past year MnDOT, with the assistance of Alliant Engineering, Inc., has conducted an evaluation of options for intersection control at the intersection of State Highways 169 and 210 in the City of Aitkin. This evaluation is in preparation for major reconstruction work planned on these two highway segments through the City of Aitkin in 2035. The purpose of the evaluation is to evaluate intersection safety, traffic mobility, and identify appropriate geometric and/or traffic control improvements to address the determined safety or operational deficiencies at the intersection. The Technical Advisory Committee (TAC) included representatives of MnDOT, Aitkin County, and the City of Aitkin. The TAC met three times during 2025 to review progress of the report. The final ICE Report is attached.

Page 34 of the report contains a summary of the four traffic control alternatives that were considered including all-way stop, modified traffic signal/cycle timing, mini-roundabout, and truck route. The recommended alternatives to enhance pedestrian safety and traffic mobility are mini roundabout with a truck route alternative.

This item is being scheduled to make the Board aware of this report and for brief discussion.

Alternatives, Options, Effects on Others/Comments:

Recommended Action/Motion:
none

Financial Impact:

Is there a cost associated with this request? Yes No

What is the total cost, with tax and shipping? \$

Is this budgeted? Yes No *Please Explain:*



US 169 & MN 210 (W JCT)

INTERSECTION CONTROL EVALUATION

REPORT

Prepared for:

MnDOT District 3
3725 12th Street North
St. Cloud, MN 56303-2107

Prepared by:

Alliant Engineering
733 Marquette Avenue, Suite 700
Minneapolis, MN 55402

2/10/2026

4000694-00

INTERSECTION CONTROL EVALUATION FOR US 169 & MN 210

City of Aitkin, Aitkin County, MN

I hereby certify that this report was prepared by me or under my direct supervision and that I am a duly Licensed Professional Engineer under the laws of the State of Minnesota.

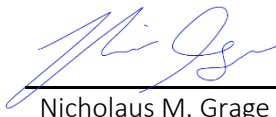

Nicholaus M. Grage

#54159

Registration No.

2/10/2026

Date

APPROVED

MnDOT District 3 Traffic Engineer

Date

REVIEWED

City of Aitkin Public Works

Date

Aitkin County Engineer

Date

TABLE OF CONTENTS

Table of Contents	ii
List of Tables	iii
List of Figures	iv
1. Introduction	1
1.1 Purpose and Need	1
1.2 Description of Location	2
1.3 Elements of Evaluation	2
2. Existing Conditions	4
2.1 Roadway and Traffic Control Characteristics.....	4
2.2 Crash Experience	6
2.2.1 Crash Rate	6
2.2.2 Crash Severity	9
2.2.3 Crash Analysis Conclusions.....	10
2.3 Traffic Volumes.....	11
2.3.1 Existing Traffic Volumes.....	11
2.3.2 Traffic Growth Rates.....	13
2.4 Traffic Operations Analysis	16
2.4.1 Level of Service Methodology	16
2.4.2 Traffic Operations Analysis Results.....	17
3. Preliminary Alternatives Analysis.....	17
3.1 Traffic Control Devices	17
3.2 Warrant and Capacity Analysis	18
3.3 Traffic Signal Warrant Analysis	18
3.4 All-Way Stop Warrant Analysis	19
3.5 Roundabout Capacity Analysis	20
3.5.1 Preferred Alternatives	21

3.6	Traffic Operations Analysis	24
3.6.1	Traffic Operations Analysis Results – Alternatives	24
3.7	Safety Analysis	26
3.8	Construction Cost Estimates	28
3.9	Benefit/Cost Analysis	29
3.10	Alternatives Evaluation Matrix	31
4.	Conclusions and Recommendations	34
5.	Appendices	35

LIST OF TABLES

Table 1.	Five-Year Crash Rate Summary	8
Table 2.	10-Year Crash Rate Summary	8
Table 3.	Level of Service Grade Definitions	16
Table 4.	Measures of Effectiveness Summary - Existing Conditions and No Build	17
Table 5.	Signal Warrant Analysis Summary	19
Table 6.	All-Way Stop Warrant Analysis Summary	19
Table 7.	Measures of Effectiveness (MOE) - Existing Year 2025	24
Table 8.	Measures of Effectiveness (MOE) - Forecast Year 2030	24
Table 9.	Measures of Effectiveness (MOE) - Forecast Year 2050	25
Table 10.	Safety Analysis Summary	27
Table 11.	Planning-Level Construct Cost Estimate Summary	28
Table 12.	Benefit/Cost Analysis Summary	30
Table 13.	Alternatives Evaluation Matrix	32

LIST OF FIGURES

Figure 1. Project Location.....	3
Figure 2. Existing Conditions	5
Figure 3. Collision Diagram.....	7
Figure 4. Existing Traffic Volumes.....	12
Figure 5. MN 210 East Leg Traffic Growth Rate Chart	13
Figure 6. Forecast Year 2030 Volumes	14
Figure 7. Forecast Year 2050 Volumes	15
Figure 8. Forecast Year 2050 Weekday Roundabout Capacity Analysis	20
Figure 9. Forecast Year 2050 Weekend Roundabout Capacity Analysis.....	21
Figure 10. Alternative 3: Mini-Roundabout.....	22
Figure 11. Alternative 4: Truck Route.....	23

1. INTRODUCTION

The Minnesota Department of Transportation (MnDOT) has identified the need to conduct an Intersection Control Evaluation (ICE) for the US Highway 169 (US 169) and Minnesota Trunk Highway 210 (MN 210) West Junction (W JCT) intersection in Aitkin, MN ahead of a 2035 resurfacing/reconstruction project in the Capital Highway Improvement Program (CHIP). The CHIP currently includes two reconstruction projects – one project on US 169 and one project on MN 210. The extents of the US 169 resurfacing/reconstruction project are from Westwood Drive to MN 210. The extents of the MN 210 reconstruction project are from 0.8 miles west of US 169 to the Ripple River Bridge.

1.1 PURPOSE AND NEED

The purpose of this ICE is to evaluate intersection safety, traffic mobility, and identify appropriate geometric and/or traffic control improvements to address the determined safety or operational deficiencies at the intersection of US 169 and MN 210 (W JCT). MnDOT is taking a proactive approach at evaluating and implementing cost-effective safety improvements that can begin to address deficiencies in the near and long term. Understanding the nature of the intersection safety problem and the need to address potential future traffic operations deficiencies, MnDOT desires an intersection improvement solution that accomplishes the following goals:

- Reduce the frequency and severity of crashes; and
- Maintain the intersection level of service into the future

To support MnDOT in identifying the appropriate intersection and traffic control improvements that meet the above stated goals, this ICE accomplishes the following:

- Documents the existing geometric, traffic operations, and safety characteristics
- Documents existing year 2025 and horizon years 2030 and 2050 traffic forecasts based upon study area historical traffic volumes and expected population growth
- Develops and evaluates high-level conceptual alternatives that will improve intersection safety characteristics to a varying degree
- Conducts a traffic operations and safety analysis of each alternative
- Develops a matrix comparing preliminary cost estimates, right of way, and other factors to help determine the optimal intersection lane geometrics and traffic control
- Identifies preferred intersection alternatives

1.2 DESCRIPTION OF LOCATION

The intersection of US 169 and MN 210 (W JCT) is in the City of Aitkin in Aitkin County, MN (see **Figure 1**: Project Location). Land use immediately surrounding the intersection is primarily downtown business district / commercial. The City of Aitkin has a population of 2,168 according to the 2020 Census.

1.3 ELEMENTS OF EVALUATION

The following elements are included in this ICE:

- Existing Conditions (Section 2.0)
- Preliminary Alternatives Analysis (Section 3.0)
- Conclusions and Recommendations (Section 4.0)

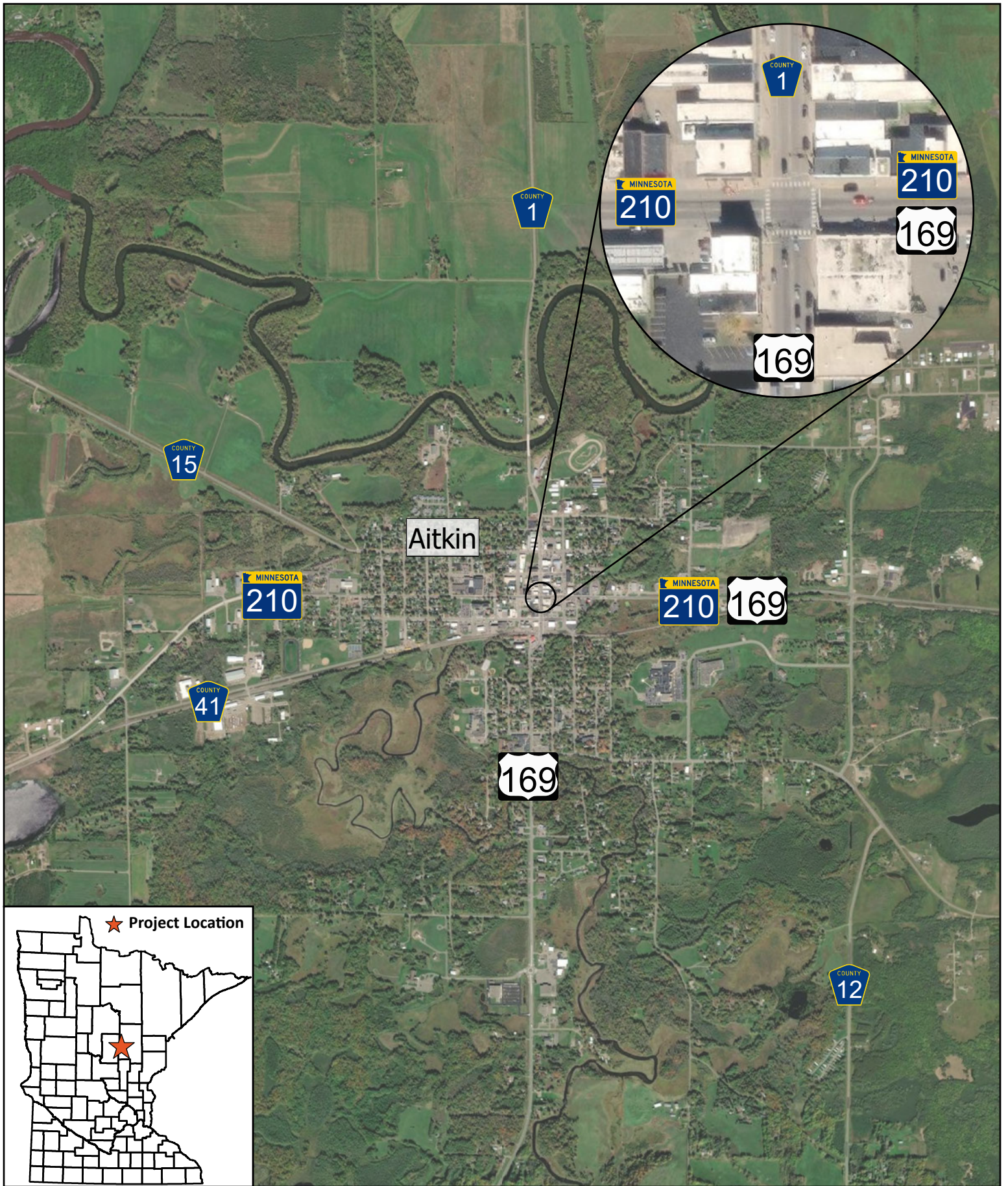

US 169 & MN 210 (W JCT) ICE

Figure 1
Project Location

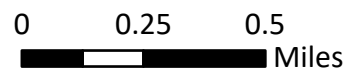

2. EXISTING CONDITIONS

The following sections document the existing conditions analysis completed for the US 169 and MN 210 (W JCT) intersection.

2.1 ROADWAY AND TRAFFIC CONTROL CHARACTERISTICS

The existing roadway characteristics are summarized below:

- **US 169** is the northbound approach at the intersection and serves as a *Principal Arterial* roadway. US 169 consists of an undivided two-lane cross-section with street parking and sidewalk facilities on both sides of the road. US 169 also follows MN 210 to the east of the study intersection. The posted speed limit is 30 miles per hour (MPH) and the Average Annual Daily Traffic (AADT) is 6,337 (2021).
- **CSAH 1 (Minnesota Avenue N)** is the southbound approach at the intersection and serves as a *Major Collector* roadway. CSAH 1 consists of an undivided two-lane cross-section with street parking and sidewalk facilities on both sides of the road. The posted speed limit is 30 MPH and the AADT is 3,853 (2024).
- **MN 210** is the eastbound and westbound approaches of the intersection and serves as a *Principal Arterial* roadway. MN 210 consists of an undivided two-lane cross-section with street parking and sidewalk facilities on both sides of the road. The posted speed limit is 30 MPH and the AADT for the east and west legs are 8,900 (2018) and 9,400 (2018), respectively.

The existing intersection characteristics are summarized as follows:

- **Intersection Control:** The US 169 and MN 210 (W JCT) intersection is currently controlled by a traffic signal. All four approaches at the intersection have pedestrian pushbuttons and crosswalk pavement markings.
 - The northbound, southbound, and eastbound approaches all operate permissively without any dedicated left-turn phasing. A dedicated westbound left-turn phase was added at the intersection in 2016 which operates protected/permissive.
- **De-facto Right-Turn Lanes:** Each intersection approach has street parking, which is restricted within 30 feet of the intersection to prevent sight line issues. This leaves a small gap between the intersection and the start of street parking. Although this area is not signed or striped as a right-turn lane, it is being used by vehicles to turn right from (on all approaches).

Key intersection characteristics, including lane geometrics and traffic control, are illustrated in **Figure 2**.

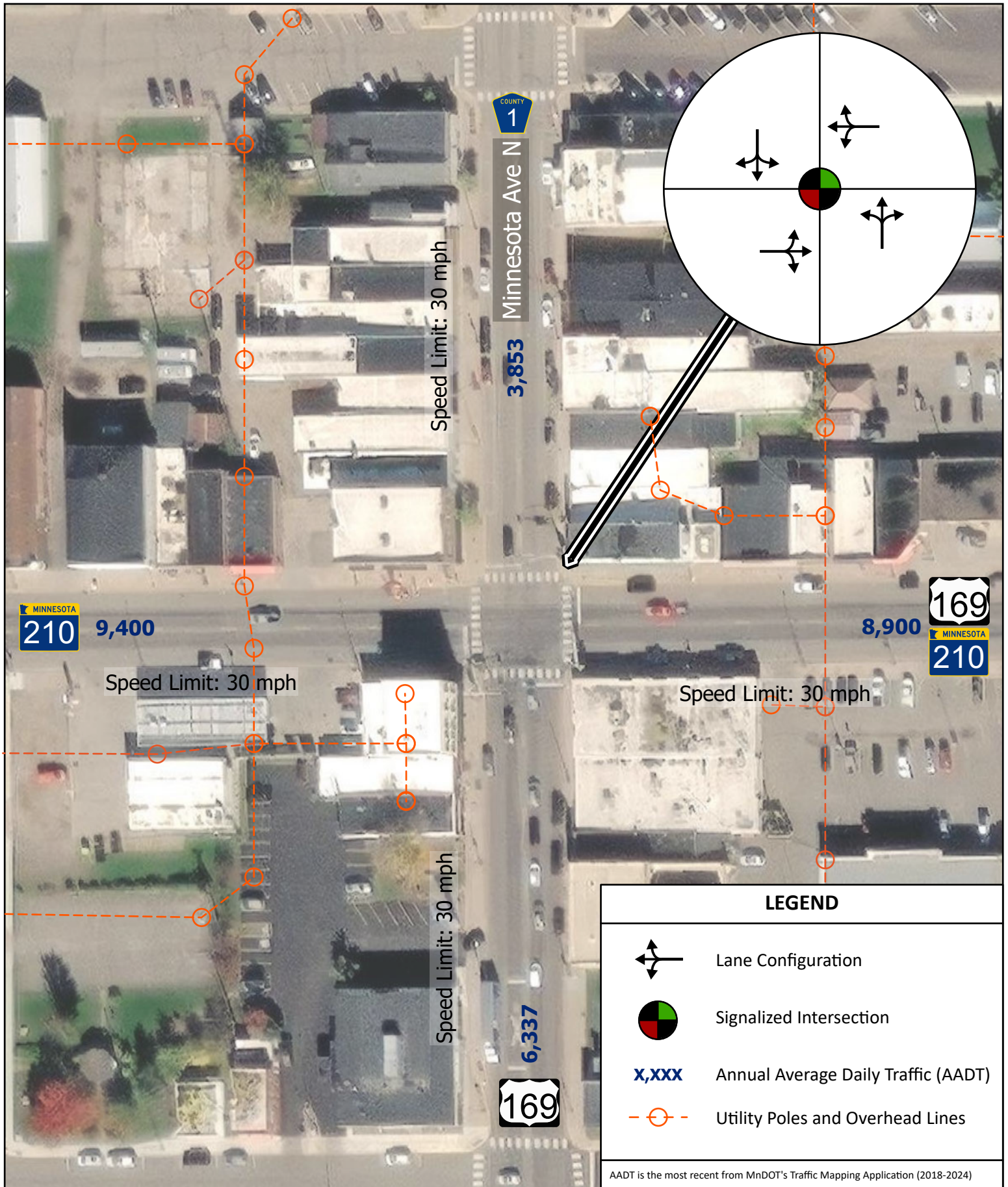

US 169 & MN 210 (W JCT) ICE

Figure 2

Existing Conditions



2.2 CRASH EXPERIENCE

Historic crash data from the most recent 10 years of data available, 2015 through 2024, was obtained from MnDOT's Crash Mapping Analysis Tool (MnCMAT2) platform. Characteristics have largely remained unchanged during this time and 10 years of data presents a more statistically relevant evaluation; however, a five-year crash rate analysis has also been included as it is the preferred analysis period for HSIP applications. It should be noted that only data from the year 2015 reflects permissive phasing on all approaches. A westbound left-turn protected/permissive phase was added at the intersection in 2016. Narratives provided by law enforcement were reviewed to ensure data accuracy. Based on the crash data provided, there were 28 reported crashes at the US 169 and MN 210 (W JCT) intersection during the 10-year analysis period (see **Figure 3**: Collision Diagram). The crashes are classified into the following types:

- 9 of 28 Crashes (32 percent) – Sideswipe
- 6 of 28 Crashes (21 percent) – Left-Turn
- 5 of 28 Crashes (18 percent) – Ped/Bike
- 3 of 28 Crashes (11 percent) – Rear End
- 2 of 28 Crashes (7 percent) – Angle
- 1 of 28 Crashes (3.6 percent) – Right-Turn
- 1 of 28 Crashes (3.6 percent) – Head On
- 1 of 28 Crashes (3.6 percent) – Run Off Road

2.2.1 CRASH RATE

History has proven that crashes are a function of exposure. Roadways with higher traffic volumes experience more crashes than similar roadways with lower volumes. Rather than simply documenting the number of crashes that occur at an intersection, the crash rate must be considered. Crash rates normalize different locations with varying traffic volumes, providing a useful tool in comparing the location with respect to safety. Actual crash rates at specific locations can also be compared to average or typical values for an intersection type. Intersection crash rates are defined as the number of crashes occurring per million entering vehicles (MEV).

Crash occurrence is somewhat random by nature. Identifying every intersection with a crash rate above the statewide average in an analysis would produce a large amount of data that may not be statistically relevant with respect to safety deficiencies. The critical crash rate identifies locations that have a crash rate higher than similar facilities by a statistically significant amount. The critical crash rate is calculated by adjusting the systemwide average based on the amount of exposure and a statistical constant indicating level of confidence. At locations where the observed crash rate exceeds the critical crash rate, it is 99.5 percent certain that an intersection or roadway segment could be improved through the modification of the existing traffic control, the configuration of the intersection, or the configuration of the roadway.

COLLISION DIAGRAM

Location: US 169 & MN 210 (W JCT)

Time Period: 2015-2025 Prepared By: CPH Date: 06/10/2025

10 Year Crash Analysis

Fatal = 0	}	Injury Total = 11
A Injury = 1		
B Injury = 4		
C Injury = 6		
Property Damage (PDD) = 17		
Total Crashes = 28		

NOT TO SCALE - CRASH LOCATIONS DEPICTED ARE NOT EXACT.

5 Year Crash Analysis

Fatal = 0	}	Injury Total = 4
A Injury = 1		
B Injury = 2		
C Injury = 1		
Property Damage (PDD) = 8		
Total Crashes = 12		

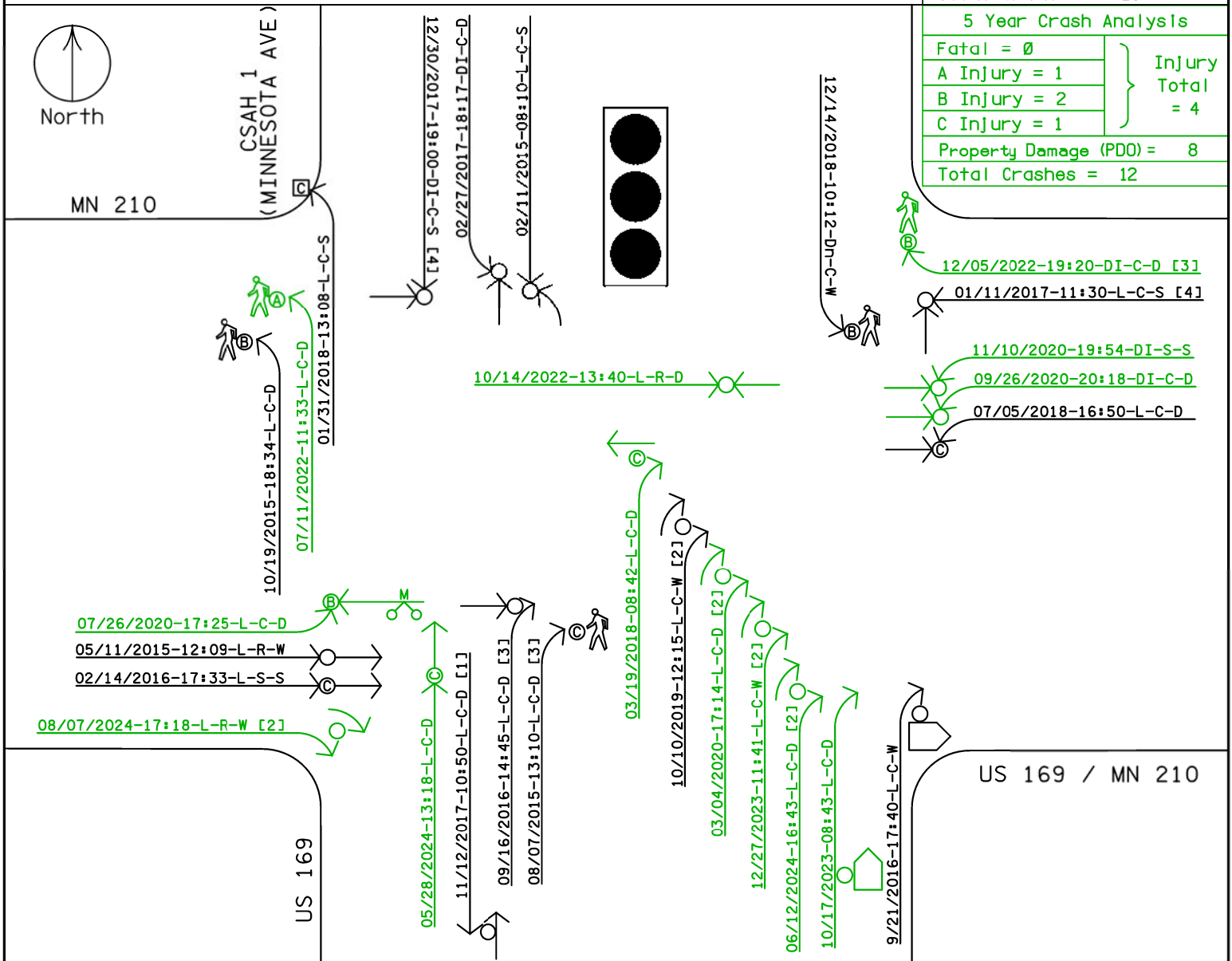

KEY

<ul style="list-style-type: none"> Vehicle Out of Control Vehicle Backing Up Vehicle Rollover Sideswipe Crash Rear End Crash Head On Crash Fixed Object Fatal Crash A Injury Crash B Injury Crash C Injury Crash PDO Crash 	<ul style="list-style-type: none"> Pedestrian Bicycle Motorcycle Parked Vehicle Left Turn Crash Right Turn Crash Right Angle Crash
--	--

NOTES

- [1] DRIVER IMPAIRED
- [2] TURNED FROM DE FACTO RIGHT-TURN LANE
- [3] RTOR
- [4] RAN RED LIGHT

Light: L = Day/Light Dn = Dawn Du = Dusk DI = Dark, Lighted DO = Dark, Lights Off D = Dark, Unlighted X = Unknown	Weather: C = Clear or Cloudy R = Rain S = Snow or Sleet F = Fog/Smog/Smoke B = Blowing Sand/Dust W = Severe Crosswinds X = Other or Unknown	Surface: D = Dry W = Wet S = Snow or Ice M = Mud/Dirt/Gravel Db = Debris O = Oily X = Other or Unknown
---	---	--

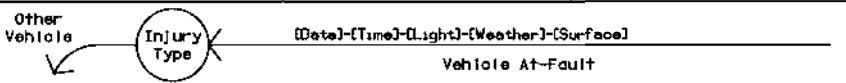

US 169 & MN 210 (W JCT) ICE

Figure 3
Collision Diagram

Table 1 and **Table 2** summarize the observed intersection crash rates compared to the statewide averages for similar traffic control types for the five- and 10-year study periods, respectively.

Table 1. Five-Year Crash Rate Summary

Intersection Crash Analysis (2020-2024)		Rate Category	Crash	Severity ⁵	K/A
Traffic Control	Traffic Signal Low Volume	Intersection	0.46	0.77	3.85
Total Crashes ¹	12	State Average ³	0.64	0.92	1.21
Total Entering Volume ²	25,997,125	Critical ⁴	1.07	1.18	5.90
K/A Crashes	1	Critical Index	0.43	0.65	0.65

1: Crash data obtained from MnCMAT2 and detailed crash narratives.

2: Calculated using AADT obtained from MnDOT's Traffic Mapping Application.

3: MnDOT's 2023 Green Sheets were used to determine state average rates.

4: A confidence level of 99.5% was assumed for critical crash rate and 90% assumed for critical severity and K/A rates.

5: Severity rate factors: 5 for Fatal, 4 for Type-A, 3 for Type-B, 2 for Type-C, and 1 for Property Damage Only crashes.

The observed five-year (2020-2024) crash rate at the intersection (0.46 crashes / MEV) is below both the statewide average for low volume traffic signals (0.64 crashes / MEV) and the corresponding critical crash rate (1.07 crashes / MEV), resulting in a critical crash rate index of 0.43. Therefore, the number of reported crashes is not considered statistically significant.

Table 2. 10-Year Crash Rate Summary

Intersection Crash Analysis (2015-2024)		Rate Category	Crash	Severity ⁵	K/A
Traffic Control	Traffic Signal Low Volume	Intersection	0.52	0.83	1.84
Total Crashes ¹	28	State Average ³	0.64	0.92	1.21
Total Entering Volume ²	54,288,579	Critical ⁴	0.93	1.10	4.04
K/A Crashes	1	Critical Index	0.55	0.75	0.46

1: Crash data obtained from MnCMAT2 and detailed crash narratives.

2: Calculated using AADT obtained from MnDOT's Traffic Mapping Application.

3: MnDOT's 2023 Green Sheets were used to determine state average rates.

4: A confidence level of 99.5% was assumed for critical crash rate and 90% assumed for critical severity and K/A rates.

5: Severity rate factors: 5 for Fatal, 4 for Type-A, 3 for Type-B, 2 for Type-C, and 1 for Property Damage Only crashes.

The observed 10-year (2015-2024) crash rate at the intersection (0.52 crashes / MEV) is below both the statewide average for low volume traffic signals (0.64 crashes / MEV), and the corresponding critical crash rate (0.93 crashes / MEV), resulting in a critical crash rate index of 0.55. Therefore, the number of reported crashes is not considered statistically significant.

2.2.2 CRASH SEVERITY

The purpose for analyzing crash severity is to identify locations that experience a low crash rate but have a high percentage of injury crashes. Conversely, locations which have high crash rates and a large proportion of property damage only (PDO) crashes may not warrant as much priority when deficiencies are being addresses. Crashes are organized into five severity types:

- Fatal (Type K)
- Serious Injury (Type A)
- Minor Injury (Type B)
- Possible Injury (Type C)
- Property Damage Only (Type PDO)

In the five-year analysis period (2020-2024), one crash resulted in serious injury (Type A), two crashes resulted in minor injury (Type B), one crash resulted in possible injury (Type C), and the remaining eight crashes resulted in property damage only (Type PDO). The observed severity rate for the five-year analysis period (0.77) is below both the statewide average (0.92) and the corresponding critical severity rate (1.18), resulting in a critical severity rate index of 0.65. Therefore, the crash severity rate is not considered statistically significant. With one serious injury crash reported, the observed five-year K/A rate (3.85 crashes / MEV) is greater than the statewide average (1.21), but lower than the corresponding critical K/A rate (5.90), resulting in a critical K/A rate index of 0.65. Therefore, the K/A rate is not considered statistically significant.

In the 10-year analysis period (2015-2024), one crash resulted in serious injury (Type A), four crashes resulted in minor injury (Type B), six crashes resulted in possible injury (Type C), and the remaining 17 crashes resulted in property damage only (Type PDO). The observed severity rate for the 10-year analysis period (0.83) is below both the statewide average (0.92) and the corresponding critical severity rate (1.10), resulting in a critical severity rate index of 0.75. Therefore, the crash severity rate is not considered statistically significant. With one serious injury crash reported, the observed 10-year K/A rate (1.84 crashes / MEV) is higher than the statewide average (1.21), but lower than the corresponding critical K/A rate (4.04), resulting in a critical K/A rate index of 0.46. Therefore, the K/A rate is not considered statistically significant.

2.2.3 CRASH ANALYSIS CONCLUSIONS

Based on the analysis of the existing intersection characteristics and crash experience, the following preliminary conclusions were made:

- The US 169 and MN 210 (W JCT) intersection has experienced 28 total reported crashes within the 10-year analysis period. The five- and 10-year crash rates are below both the statewide average and the corresponding critical rate. Therefore, the number of reported crashes is not considered statistically significant.
- The five- and 10-year severity rates are below both the statewide average and the corresponding critical severity rate. Therefore, the severity distribution is not considered statistically significant.
- With one serious injury (Type A) crash reported at the intersection, the five- and 10-year K/A rates are above the statewide average, but below the corresponding critical rate. Therefore, the number of fatal (Type K) and serious injury (Type A) crashes is not considered statistically significant.
- The predominant crash type at the intersection was sideswipe crashes, accounting for nine of the 28 total crashes. Two of the sideswipe crashes were collisions with parked cars, one was a sideswipe-opposing crash with an impaired driver, and the remaining six sideswipe crashes occurred due to confusion over the de facto right-turn lanes. This primarily occurred at the northbound right-turn (four crashes) with one crash occurring at the eastbound right-turn.
- It should be noted that five pedestrian crashes occurred within the 10-year analysis period. Three pedestrian crashes involved a left-turning vehicle and the other two crashes involved a right-turning vehicle (both right-turn on red). 100 percent of the pedestrian crashes resulted in an injury with one serious injury (Type A), three minor injury (Type B), and one possible injury (Type C).

2.3 TRAFFIC VOLUMES

This ICE evaluated intersection geometric and traffic control needs are based upon existing year 2025, forecast year 2030 and forecast year 2050 design horizons.

2.3.1 EXISTING TRAFFIC VOLUMES

Weekday turning movement counts were collected by Alliant Engineering the week of May 7th, 2025. The weekday AM and PM peak hours were determined to be 7:30 AM – 8:30 AM and 3:15 PM – 4:15 PM, respectively. Friday and Sunday turning movement counts were collected by Alliant Engineering on May 9th and May 11th, 2025, respectively. The Friday and Sunday peak hours were determined to be 3:15 PM – 4:15 PM and 12:15 – 1:15 PM, respectively. Detailed TMCs are included in **Appendix A**.

SEASONAL AND RECREATIONAL TRAFFIC VOLUMES

The US 169 and MN 210 (W JCT) intersection experiences high weekend recreational traffic volumes during the summer months. Peak hours associated with the recreational traffic are often higher or, at the very least, directional which can cause distinct operational patterns resulting in increased delay, queuing, and crashes. Two permanent Automatic Traffic Recorder (ATR) stations are located along US 169 just north (Station 4200) and south (Station 2300) of the study intersection. ATR data at Station 2300, located approximately 7 miles south of the study intersection, was found to be more representative of traffic volumes and patterns at the study intersection compared to the data from Station 4200. A detailed analysis was completed to compare TMCs collected in May of 2025 to May ATR data from Station 2300 as well as the summer months of June, July, and August.

Based on the data analyzed, Friday traffic volumes were on average 11 percent higher in the summer months than in May. Sunday traffic volumes were found to be on average five percent higher in the summer months than in May. Therefore, 1.11 and 1.05 volume adjustment factors were applied to the collected TMC data for Friday and Sunday, respectively, to more accurately represent typical weekend recreational traffic volumes. These volumes are a conservative estimate of peak volumes at the intersection. Existing weekday AM and PM peak volumes, and adjusted Friday and Sunday peak volumes, are illustrated in **Figure 4**.

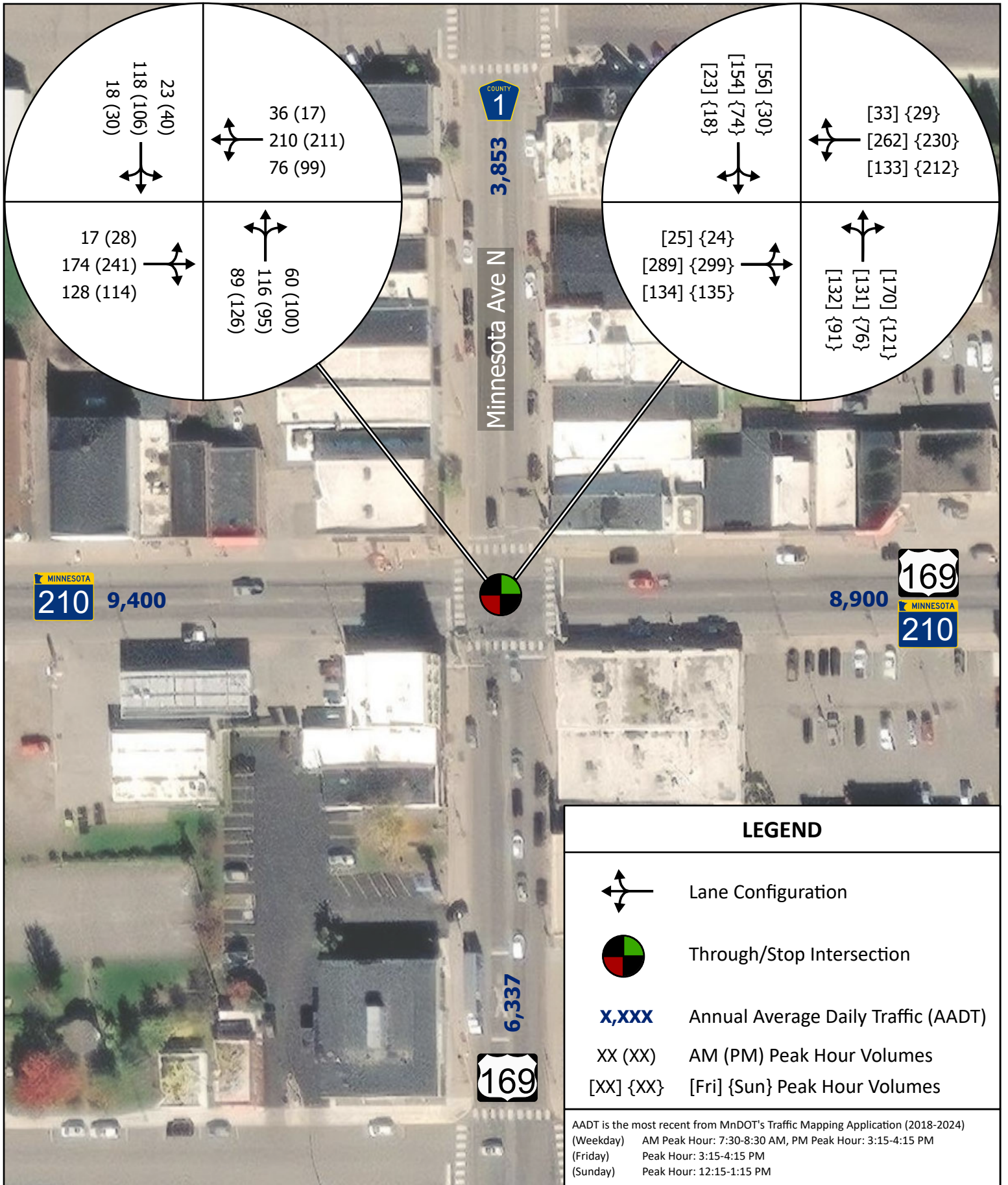

US 169 & MN 210 (W JCT) ICE

Figure 4
Existing Year 2025 Traffic Volumes

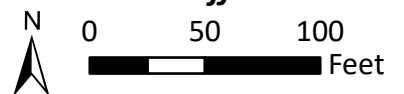

2.3.2 TRAFFIC GROWTH RATES

Historic AADT data was obtained to determine traffic growth trends at the US 169 and MN 210 (W JCT) intersection. Recent data shows that traffic volumes have generally increased over time for each of the intersection approaches except for the US 169 south leg, which has shown a steady decrease in traffic volumes starting in 2006. MnDOT’s Traffic Forecast for Cumulative ESAL worksheet recommended a growth rate between 0.50 percent and 1.37 percent for the intersection legs. Average Daily Traffic (ADT) values were estimated using the turning movement counts collected at the intersection in May of 2025. Based on the historic AADT analysis and results of the MnESAL analysis, a 1.0 percent annual traffic growth rate is recommended for the study intersection.

Figure 5 below shows the traffic growth rate analysis for the MN 210 east leg. Historic AADTs are shown in blue and estimated 2025 ADT is shown in purple. Forecast year 2030 and 2050 ADTs were calculated using the recommended 1.0 percent traffic growth rate and are shown in green below. Traffic growth rate charts for the remaining intersection legs, as well as the MnESAL results, are included in **Appendix B**.

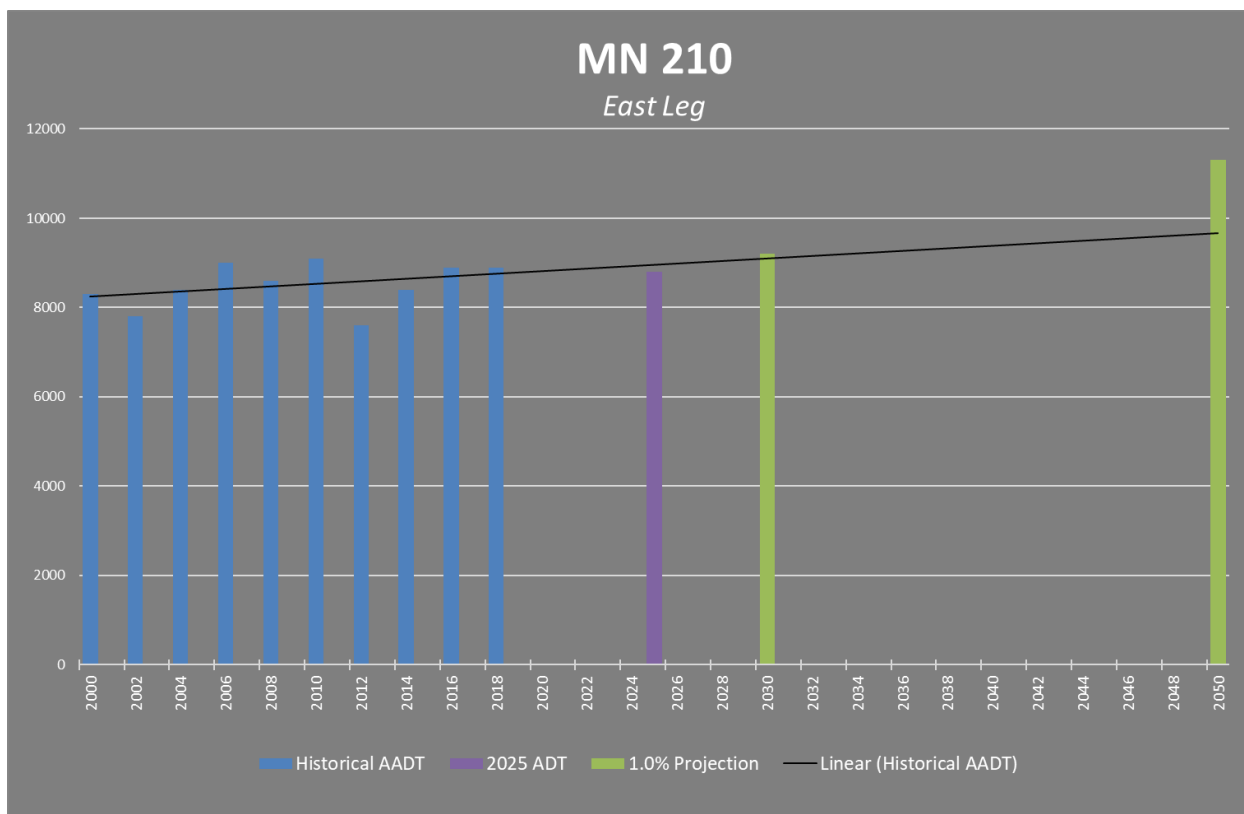
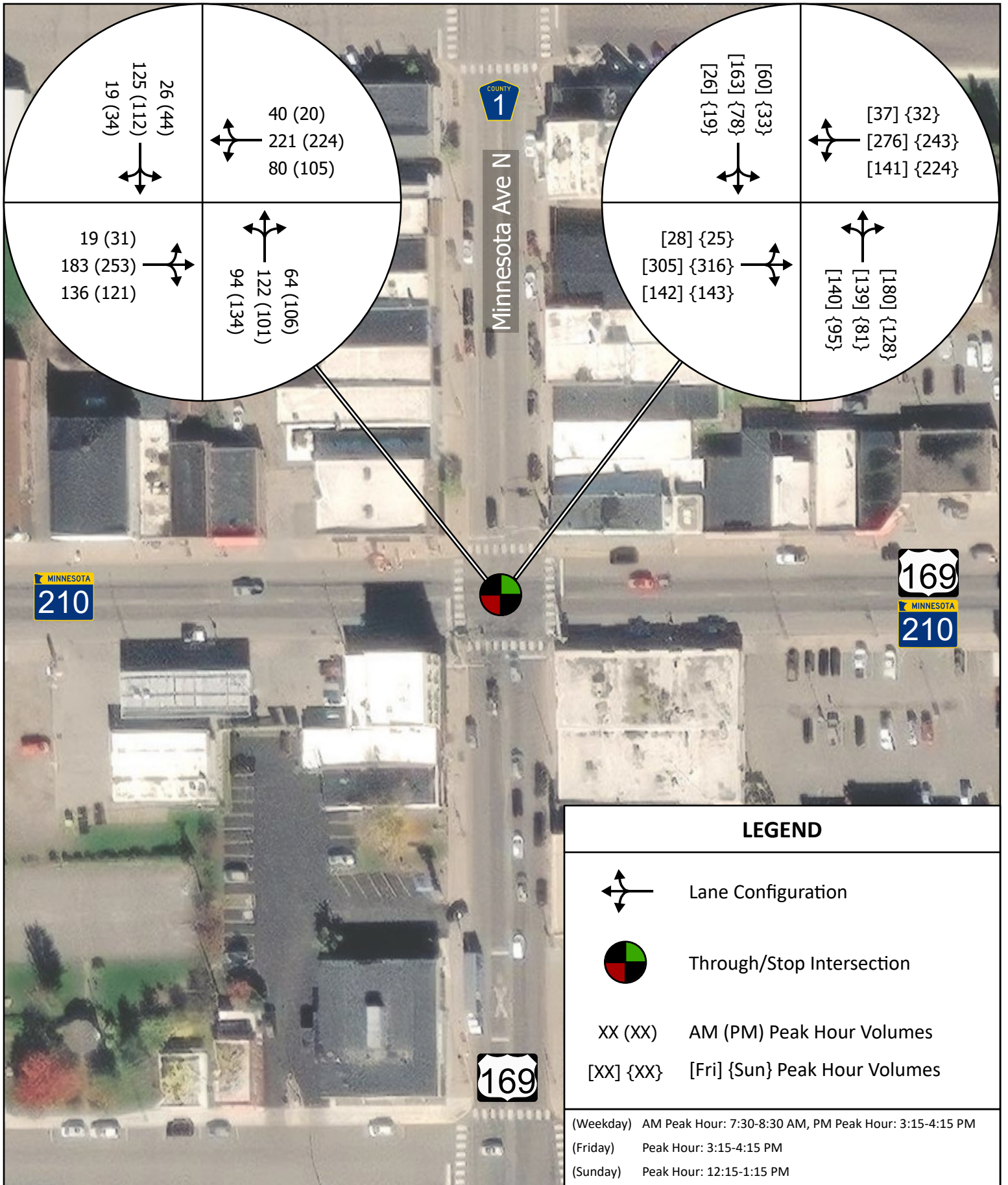

Figure 5. MN 210 East Leg Traffic Growth Rate Chart

Forecast year 2030 and 2050 volumes were calculated using the recommended 1.0 percent growth rate and are shown in **Figure 6** and **Figure 7**, respectively.



US 169 & MN 210 (W JCT) ICE

Figure 6
Forecast Year 2030 Traffic Volumes

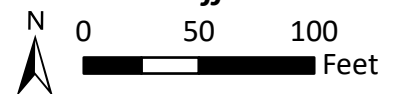

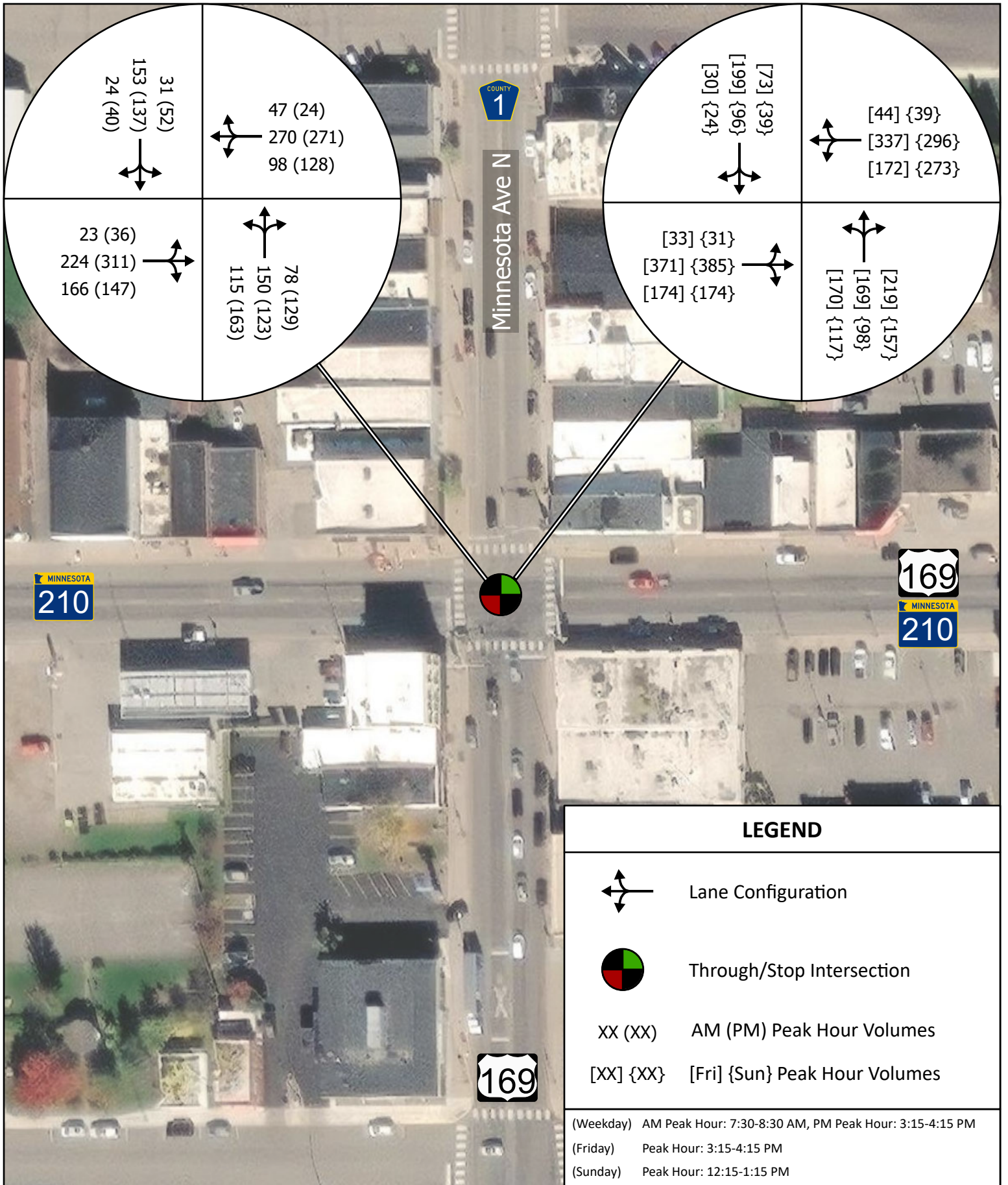

US 169 & MN 210 (W JCT) ICE

Figure 7

Forecast Year 2050 Traffic Volumes

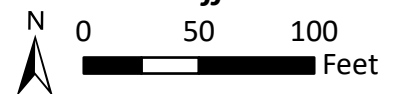

2.4 TRAFFIC OPERATIONS ANALYSIS







Understanding existing mobility of the study intersection is an important first step to identifying operational concerns. To do so, an assessment of the existing quality of mobility was completed. Using Level of Service (LOS) methodology, the quality of traffic flow was measured at the intersection under existing conditions using existing year 2025, forecast year 2030, and forecast year 2050 peak hour traffic volumes. The intersection was modeled using Synchro/SimTraffic. Results of the operations analysis, including explanation of the level of service methodology, are summarized in the following sections.

2.4.1 LEVEL OF SERVICE METHODOLOGY

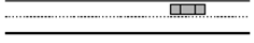
LOS is a concept used to estimate the quality of traffic flow through intersections and along roadway segments. In general, the capacity of a street is a measure of its ability to accommodate a certain volume of moving vehicles. Typically, street capacity refers to the maximum number of vehicles that can be expected to be accommodated in a given time period under the prevailing roadway characteristics and conditions. The LOS methodology is standardized by the Transportation Research Board (TRB) and is applied uniformly regardless of jurisdictional boundaries. The LOS method for arterial streets assigns an LOS grade based on delay and driver expectations of acceptable delay for the intersection control type.

LOS results are categorized on an A through F scale. LOS A represents high quality traffic operations where motorists experience little or no delay (i.e., free flow conditions). Conversely, LOS F corresponds to low quality operations with significant delays and potentially congestion. The overall intersection LOS grade is based on the weighted average delay of each movement. The delays can vary greatly based on traffic volume, lane geometry, and intersection traffic control (i.e., traffic signal, through-stop, all way stop). Grades are different at unsignalized and signalized intersections due to drivers' expectations of longer delays at signalized intersections. Although the measure of effectiveness used in determining LOS for different facility types (e.g., arterial street, rural highway, signalized intersection) may differ, the concept of the LOS grade is the same. The general relationship between capacity and LOS is displayed in **Table 3**.

Table 3. Level of Service Grade Definitions

Level of Service	Description	Delay per Vehicle (seconds)	
		Signalized Intersection	Unsignalized Intersection
A	 Free Flow: Low volumes and no delays.	0 - 10	0 - 10
B	 Stable Flow: Speeds restricted by travel conditions, minor delays.	> 10 - 20	> 10 - 15
C	 Stable Flow: Speeds and maneuverability closely controlled due to higher volumes.	> 20 - 35	> 15 - 25
D	 Stable Flow: Speeds considerably affected by change in operating conditions. High density traffic restricts maneuverability, volume near capacity.	> 35 - 55	> 25 - 35
E	 Unstable Flow: Low speeds, considerable delay, volume at or slightly over capacity.	> 55 - 80	> 35 - 50
F	 Forced Flow: Very low speeds, volume exceed capacity, long delays with stop and go traffic.	> 80	> 50

Source: Highway Capacity Manual, 2010 Edition, Transportation Research Board, Exhibits 18-4 & 19-1.

2.4.2 TRAFFIC OPERATIONS ANALYSIS RESULTS

Results of the existing and no build traffic operations analysis are shown in **Table 4**. Results of the existing traffic operations analysis show that the study intersection operates adequately during the existing 2025 and forecast year 2030 weekday peaks with overall intersection and worst approach LOS C. However, operations deteriorate under forecast year 2050 weekday volumes, resulting in overall intersection LOS D/E and worst approach LOS E/F.

Under existing Friday and Sunday peak hour volumes, the intersection operates with overall intersection LOS E/C with significant worst approach delay (LOS F/D). Operations deteriorate significantly under increased volumes, with overall intersection and worst approach LOS F in 2050. Detailed measures of effectiveness results are included in **Appendix C**.

Table 4. Measures of Effectiveness Summary - Existing Conditions and No Build

Volume Scenario	AM Peak Hour		PM Peak Hour		FRI Peak Hour		SUN Peak Hour	
	LOS	Delay (s)	LOS	Delay (s)	LOS	Delay (s)	LOS	Delay (s)
Existing Year 2025 Conditions	C / C	24.8 / 28.3	C / C	26.7 / 29.4	E / F	56.2 / 84.0	C / D	33.8 / 43.1
Forecast Year 2030 No Build Conditions	C / C	25.7 / 29.5	C / C	29.8 / 32.8	F / F	81.2 / 149.5	D / E	42.3 / 61.7
Forecast Year 2050 No Build Conditions	D / E	40.5 / 55.4	E / F	55.5 / 88.2	F / F	364.6 / 730.2	F / F	210.9 / 530.9

Overall Intersection LOS / Worst Approach LOS
Overall Intersection Delay / Worst Approach Delay

3. PRELIMINARY ALTERNATIVES ANALYSIS

To address intersection safety concerns and preserve traffic mobility, a preliminary alternatives analysis was completed. The goal of the alternatives analysis was to identify engineering considerations, expected traffic operations and safety impacts, and to present the key decision-making factors that aid in developing the study recommendations.

3.1 TRAFFIC CONTROL DEVICES

An iterative process was used to develop intersection traffic control and geometric alternatives at the study intersection with the goal of improving safety and preserving mobility for all users into the future. Preliminary analysis considered the following traffic control devices:

- **Traffic Signal** – Continuation of existing traffic signal control with potential lane configuration changes
- **All-Way Stop** – Conversion of existing traffic signal control to all-way stop control, with potential lane configuration changes
- **Roundabout** – Construct a roundabout at the intersection

3.2 WARRANT AND CAPACITY ANALYSIS

A traffic signal and all way stop warrant analysis, as well as a preliminary roundabout capacity analysis, were completed for the US 169 and MN 210 (W JCT) intersection. The traffic signal and all-way stop warrant analysis were completed in accordance with the Minnesota Manual on Uniform Traffic Control Devices (MnMUTCD). The MnMUTCD contains specific engineering standards, or warrants, that define the minimum conditions under which further consideration of an all way stop or traffic signal is appropriate. These warrants are important for applying consistency in traffic control across intersections throughout the transportation system.

3.3 TRAFFIC SIGNAL WARRANT ANALYSIS

A signal warrant analysis was completed for the US 169 and MN 210 (W JCT) intersection under existing year 2025, forecast year 2030, and forecast year 2050 traffic volumes. The warrant analysis was conducted in accordance with the MnMUTCD. For a traffic signal to be considered for implementation at the intersection, at least one of the following warrant criteria must be met:

- **Warrant 1:** Eight-Hour Vehicular Volume
- **Warrant 2:** Four-Hour Vehicular Volume
- **Warrant 3:** Peak Hour
- **Warrant 4:** Pedestrian Volume
- **Warrant 5:** School Crossing
- **Warrant 6:** Coordinated Signal System
- **Warrant 7:** Crash Experience
- **Warrant 8:** Roadway Network
- **Warrant 9:** Intersection Near a Grade Crossing

Warrant 1, Warrant 2, and Warrant 3 were reviewed under existing and forecast traffic volumes for weekday conditions. Warrant 7 was reviewed using historical crash data. The remaining traffic signal warrants are not applicable at the US 169 and MN 210 (W JCT) intersection, or minimum warrant standards are not met. The right-turn volumes on the minor street approaches were either included or omitted based on existing lane configurations and the recommended procedures documented in the MnDOT ICE Manual. **Table 5** presents a summary of the MnMUTCD signal warrant analysis results. The detailed signal warrant analysis results are included in **Appendix D**.

Table 5. Signal Warrant Analysis Summary

Volume Scenario	Warrant 1 - Eight-Hour Vehicular Volumes				Warrant 2 - Four-Hour Vehicular Volumes		Warrant 3 - Peak Hour		Warrant 7 - Crash Experience	
	1A	1B	1C	Met?	Hours	Met?	3B	Met?	Crashes	Met?
2025 Existing	12	10	11	YES	12	YES	11	YES	3	NO
2030 No Build	12	10	12	YES	12	YES	11	YES	3	NO
2050 No Build	13	12	12	YES	13	YES	12	YES	3	NO

Results of the signal warrant analysis indicate that all three volume scenarios meet Warrant 1 (Eight-Hour Vehicular Volumes), Warrant 2 (Four-Hour Vehicular Volumes), and Warrant 3 (Peak Hour). Therefore, a traffic signal is warranted under existing and forecast year volume scenarios.

3.4 ALL-WAY STOP WARRANT ANALYSIS

An all-way stop warrant analysis was completed for the US 169 and MN 210 (W JCT) intersection under existing year 2025, forecast year 2030, and forecast year 2050 volumes. The warrant analysis was conducted in accordance with the MnMUTCD. For an all-way stop to be considered, one of the following warrant criteria must be met:

- **Warrant Criteria A** – Signal Justified
- **Warrant Criteria B** – Crash Experience
- **Warrant Criteria C** – Minimum Volumes and Major Approach Maximum Delay

Results of the all-way stop warrant analysis are summarized in **Table 6**.

Table 6. All-Way Stop Warrant Analysis Summary

Volume Scenario	Criteria A - Signal Justified	Criteria B - Crash History		Criteria C - Minimum Volumes and Minor Approach Maximum Delay		
	Met?	Crashes	Met?	C1	C2	Met?
2025 Existing	YES	3	NO	12	29	NO
2030 No Build	YES	3	NO	12	32	YES
2050 No Build	YES	3	NO	14	88	YES

Results of the all-way stop warrant analysis indicate that Criteria A is met under all existing and forecast year volume scenarios. Additionally, Criteria C is met under both forecast year scenarios. Therefore, an all-way stop is warranted for existing and forecast year traffic volumes.

3.5 ROUNDABOUT CAPACITY ANALYSIS

A planning-level roundabout capacity analysis was completed for the US 169 and MN 210 intersection under existing year 2025, forecast year 2030, and forecast year 2050 traffic volumes for weekday conditions. The analysis was conducted in accordance with the Highway Capacity Manual (HCM 2016). The purpose of the analysis was to determine whether a roundabout would be a suitable alternative for the intersection under existing and forecast traffic volumes.

Results of the roundabout capacity analysis using forecast year 2050 weekday and weekend traffic volumes are shown in

Figure 8 and Figure 9, respectively. Results indicate that a single-lane roundabout is expected to accommodate peak hour weekday and weekend traffic volumes for existing year 2025, forecast year 2030, and forecast year 2050. Additional planning-level roundabout capacity analyses are included in Appendix E.

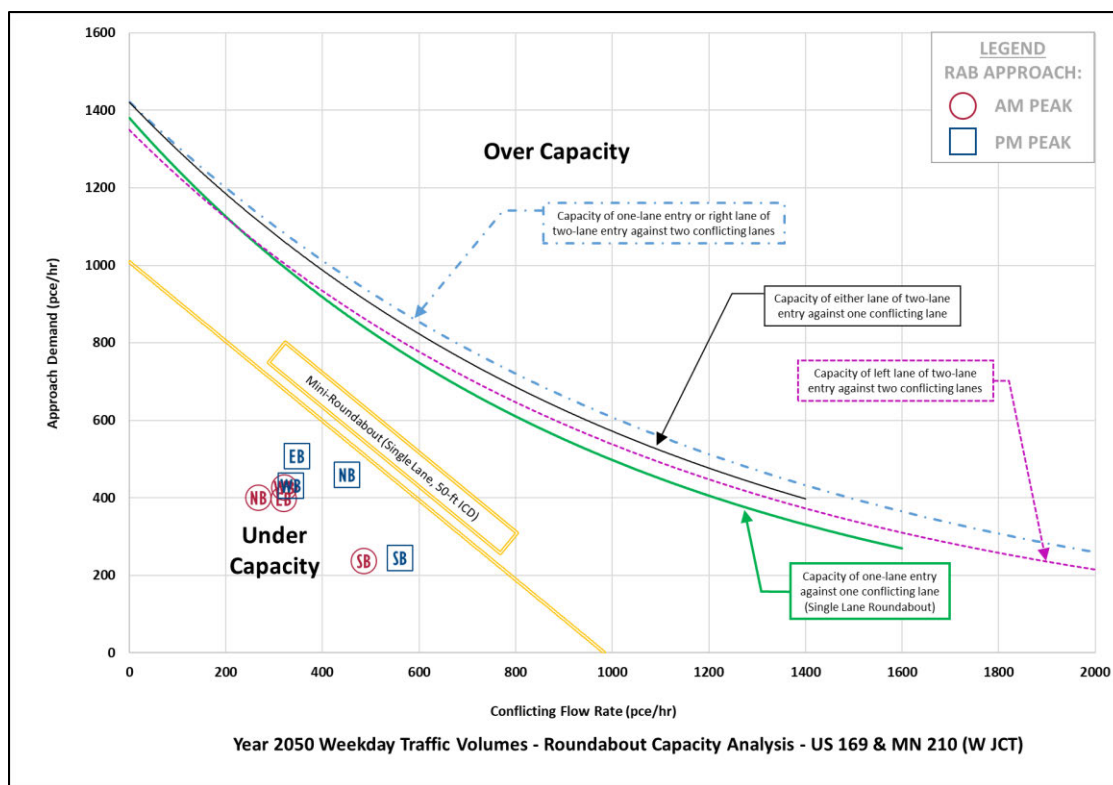

Figure 8. Forecast Year 2050 Weekday Roundabout Capacity Analysis

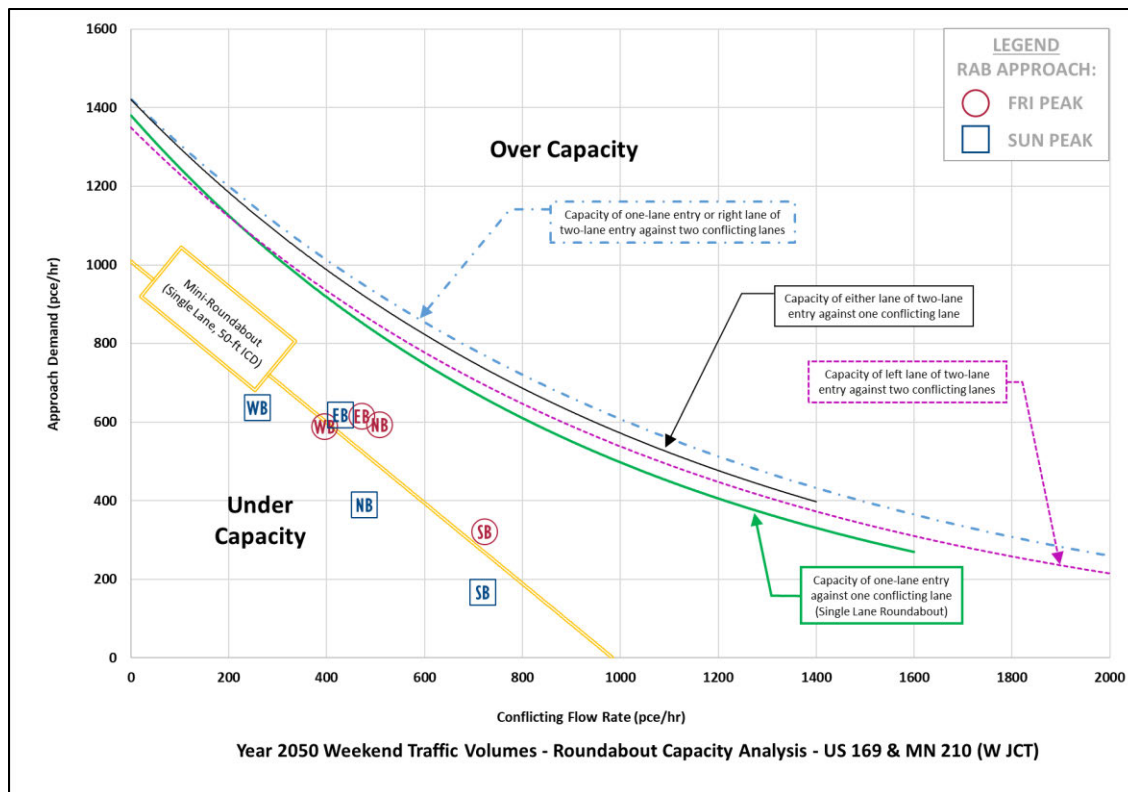
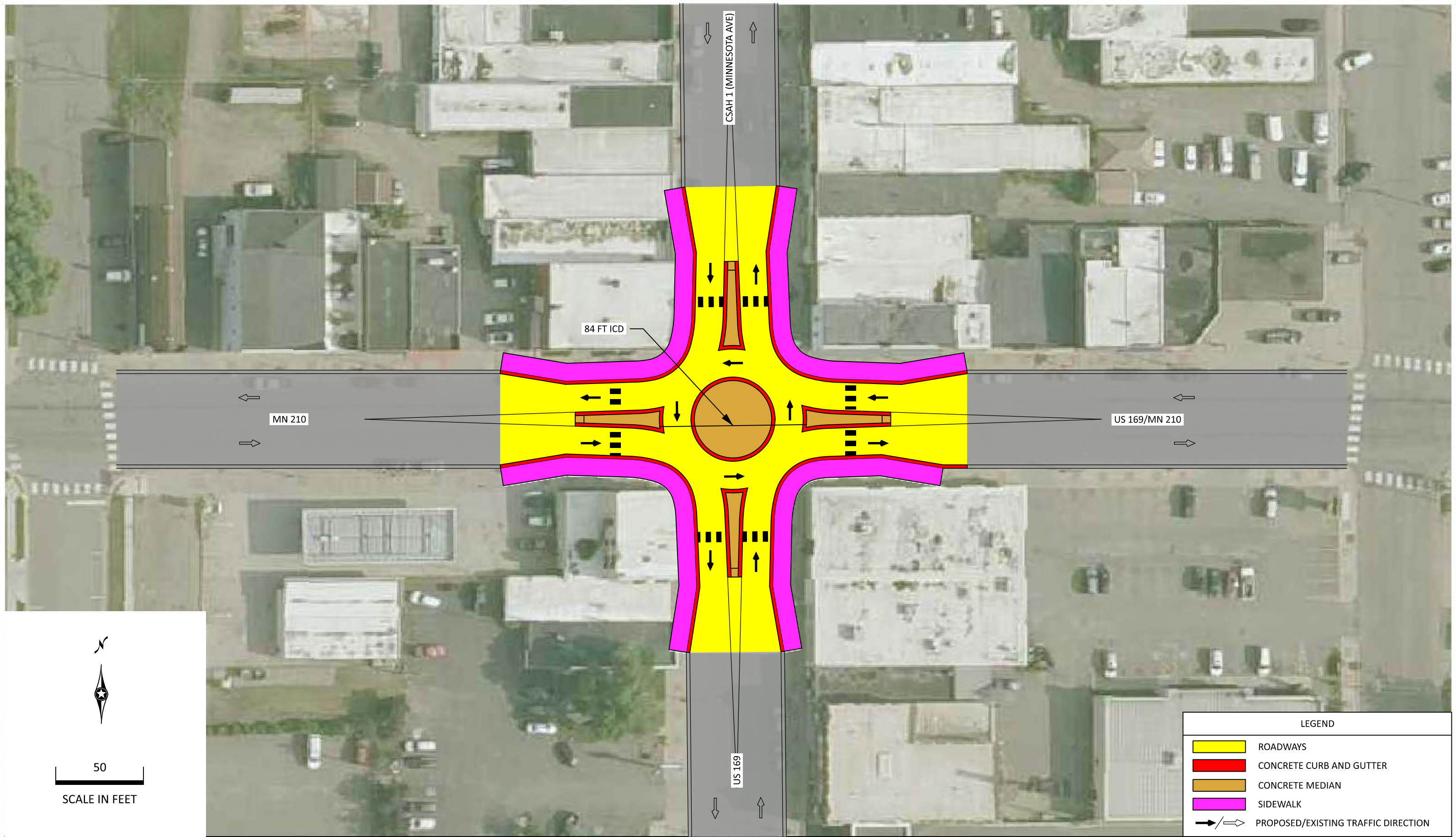

Figure 9. Forecast Year 2050 Weekend Roundabout Capacity Analysis

3.5.1 PREFERRED ALTERNATIVES

Based on the results of the warrant and capacity analysis, three intersection alternatives were developed. Intersection alternatives are detailed below:

- **Alternative 0: No Build** – Continuation of existing signal control without any changes to existing lane configuration
- **Alternative 1: All-Way Stop** – Implementation of all-way stop control without any changes to existing lane configuration
- **Alternative 2: Modified Signal Timing** – This alternative includes replacement of the existing signal system without any changes to existing lane configurations. The traffic signal will still operate free, with increased green time for the westbound left-turn phase
- **Alternative 2A: Modified Signal Timing + Dedicated Right-Turn Lanes** – This alternative includes replacement of the existing signal system and the same signal timing changes as Alternative 2. Additionally, street parking will be further restricted to provide dedicated right-turn lanes for each approach
- **Alternative 3: Mini Roundabout** – Construct a mini roundabout at the intersection. A high-level conceptual layout of Alternative 3 is included in **Figure 10**
- **Alternative 4: Truck Route** – This alternative would sign a route for MN 47 and CSAH 12 that re-routes heavy commercial vehicle traffic outside of downtown Aitkin. The proposed truck route is shown in **Figure 11**



US 169 & MN 210 (W JCT) ICE

Figure 10
Alternative 3: Mini-Roundabout

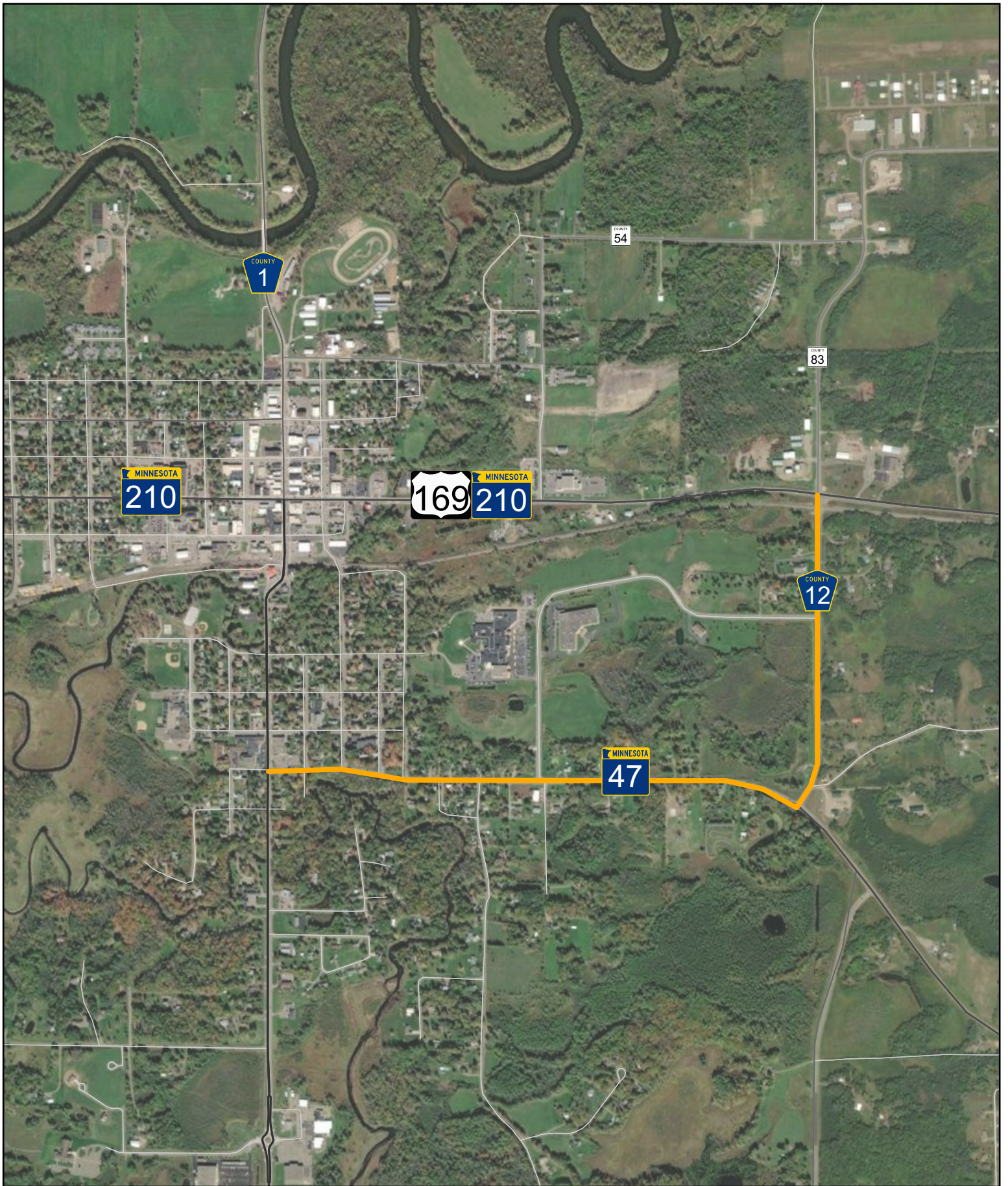

US 169 & MN 210 (W JCT) ICE

Figure 11

Alternative 4: Truck Route

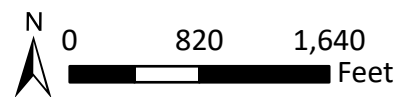

3.6 TRAFFIC OPERATIONS ANALYSIS

A traffic operations analysis was completed for each alternative under existing year 2025, forecast year 2030, and forecast year 2050 peak hour traffic volumes. Non-roundabout alternatives were modeled using Synchro/SimTraffic. Alternative 3: Mini Roundabout was modeled using VISSIM. The purpose of this analysis is to evaluate and compare the performance of each preferred alternative.

3.6.1 TRAFFIC OPERATIONS ANALYSIS RESULTS – ALTERNATIVES

Results of the alternatives traffic operations analysis for existing year 2025, forecast year 2030, and forecast year 2050 are summarized in **Table 7**, **Table 8**, and **Table 9**, respectively. Detailed measures of effectiveness are included in **Appendix F**.

Table 7. Measures of Effectiveness (MOE) - Existing Year 2025

Alternative	AM Peak Hour		PM Peak Hour		FRI Peak Hour		SUN Peak Hour	
	LOS	Delay (s)	LOS	Delay (s)	LOS	Delay (s)	LOS	Delay (s)
Existing Conditions	C / C	24.8 / 28.3	C / C	26.7 / 29.4	E / F	56.2 / 84.0	C / D	33.8 / 43.1
Alternative 1: All-Way Stop	C / D	17.6 / 27.5	C / D	18.7 / 28.0	F / F	60.7 / 95.2	D / E	25.6 / 40.4
Alternative 2: Modified Signal Timing	C / C	20.2 / 27.4	C / C	29.9 / 33.3	E / E	60.3 / 77.6	D / D	35.6 / 41.5
Alternative 2A: Modified Signal Timing +RTLs	B / C	17.8 / 24.8	C / C	25.0 / 25.9	D / D	37.3 / 43.4	C / C	27.3 / 30.8
Alternative 3: Mini Roundabout	A / A	2.1 / 2.5	A / A	2.9 / 3.4	A / A	4.0 / 5.0	A / A	2.9 / 3.6
Alternative 4: Truck Route	C / C	21.4 / 23.7	C / C	26.2 / 28.2	D / E	41.8 / 56.0	C / D	31.9 / 41.7

Overall Intersection LOS / Worst Approach LOS
Overall Intersection Delay / Worst Approach Delay

Table 8. Measures of Effectiveness (MOE) - Forecast Year 2030

Alternative	AM Peak Hour		PM Peak Hour		FRI Peak Hour		SUN Peak Hour	
	LOS	Delay (s)	LOS	Delay (s)	LOS	Delay (s)	LOS	Delay (s)
2030 No Build	C / C	25.7 / 29.5	C / C	29.8 / 32.8	F / F	81.2 / 149.5	D / E	42.3 / 61.7
Alternative 1: All-Way Stop	C / D	19.2 / 30.6	C / D	20.4 / 30.1	F / F	92.9 / 165.0	D / F	30.8 / 52.1
Alternative 2: Modified Signal Timing	C / C	28.2 / 31.9	C / C	32.4 / 34.9	E / F	79.4 / 100.0	D / D	43.2 / 54.3
Alternative 2A: Modified Signal Timing +RTLs	C / C	23.5 / 26.1	C / C	26.5 / 27.8	D / D	39.3 / 44.9	C / C	29.5 / 34.2
Alternative 3: Mini Roundabout	A / A	2.3 / 2.7	A / A	3.1 / 3.6	A / A	4.5 / 5.8	A / A	3.2 / 4.0
Alternative 4: Truck Route	C / C	24.8 / 28.6	C / C	26.9 / 29.9	D / E	49.1 / 70.2	D / E	41.1 / 60.1

Overall Intersection LOS / Worst Approach LOS
Overall Intersection Delay / Worst Approach Delay

Table 9. Measures of Effectiveness (MOE) - Forecast Year 2050

Alternative	AM Peak Hour		PM Peak Hour		FRI Peak Hour		SUN Peak Hour	
	LOS	Delay (s)	LOS	Delay (s)	LOS	Delay (s)	LOS	Delay (s)
2050 No Build	D / E	40.5 / 55.4	E / F	55.5 / 88.2	F / F	364.6 / 730.2	F / F	210.9 / 530.9
Alternative 1: All-Way Stop	D / F	34.6 / 61.3	F / F	56.7 / 89.8	F / F	388.3 / 674.2	F / F	176.9 / 418.6
Alternative 2: Modified Signal Timing	D / D	45.7 / 53.0	E / E	56.7 / 64.9	F / F	356.9 / 564.1	F / F	178.7 / 417.0
Alternative 2A: Modified Signal Timing +RTLs	C / D	32.0 / 37.9	D / D	38.1 / 43.5	F / F	191.8 / 290.5	E / F	57.0 / 94.1
Alternative 3: Mini Roundabout	A / A	3.0 / 3.6	A / A	4.5 / 5.2	A / A	7.6 / 9.8	A / A	5.0 / 5.9
Alternative 4: Truck Route	C / D	29.8 / 36.1	D / E	51.0 / 65.3	F / F	262.9 / 547.4	F / F	189.0 / 461.2

Overall Intersection LOS / Worst Approach LOS
Overall Intersection Delay / Worst Approach Delay

Key findings of the operations analysis are listed below:

- All alternatives are expected to improve worst approach delay under the forecast year 2050 Friday and Sunday peak hours. Despite this improvement, all alternatives are expected to operate at overall intersection and worst approach LOS E/F by 2050 (weekdays), except for the mini-roundabout alternative.
- Results for Alternative 1: All-Way Stop and Alternative 2: Modified Signal Timing show minimal change from the No Build for weekday peak hours. The remainder of the alternatives show improved overall intersection and worst approach delay for the weekday peak hours.
- Considering the high westbound left -turn volumes at the intersection, the modified signal timing alternatives increase green time for the westbound left-turn phase while maintaining the free operations of the existing signal. Increasing green time for the westbound left-turn phase results in less green time for the eastbound phase. However, eastbound and westbound through volumes are also very high, and without a dedicated westbound left-turn lane, any vehicle waiting to make a westbound left-turn during the permissive turning phase has a small chance of finding a gap in eastbound traffic. Therefore, the westbound queues become substantial. Without making changes to lane configurations, it is difficult to improve operations under a signalized alternative.
 - It should be noted that operations under Alternative 2A: Modified Signal Timing + Dedicated Right-Turn Lanes do improve compared to both the No Build and Alternative 2: Modified Signal Timing (without lane configuration changes). The implementation of left-turn lanes (specifically for the westbound approach) would be expected to improve operations under a signalized alternative.
- Alternative 3: Mini Roundabout is the only alternative that is expected to significantly improve operations under all peak hour volume scenarios into forecast year 2050. Under the mini roundabout alternative, the intersection is expected to operate at overall intersection and worst approach LOS A under all weekday and weekend peak hours.

3.7 SAFETY ANALYSIS

A detailed safety analysis was completed to understand the anticipated safety improvement of each alternative. The safety analysis included investigating the change in crash types and/or the elimination of certain crash types for each alternative.

Alternative 1: All-Way Stop and Alternative 2: Optimized Signal Timing are expected to have the same expected safety as the No Build. The future safety impact of Alternative 2A: Optimized Signal Timing + Dedicated Right-Turn Lanes was estimated by assuming that all sideswipe-same crashes would be eliminated by pushing the start of parking further away from the intersection, and by providing a clearly designated right-turn lane for each approach. The future safety impact of Alternative 3: Mini-Roundabout were estimated using statewide average values for similar intersection types. The statewide average crash rate and severity distribution for single-lane roundabouts from MnDOT's *A Study of Traffic Safety at Roundabouts in Minnesota* were utilized to estimate expected future crashes for the roundabout alternative. The future safety impact of Alternative 4: Truck Route was estimated by assuming all crashes that involved a heavy commercial vehicle would be eliminated. It should be noted that this estimate assumes that 100 percent of trucks will use the truck route, which may be a conservative estimate. **Table 10** summarizes the results of the safety analysis, while detailed results are included in **Appendix G**.

Key findings of the safety analysis are listed below:

- No changes to safety are expected under Alternative 1: All-Way Stop or Alternative 2: Optimized Signal Timing.
- Alternative 2A: Optimized Signal Timing + Dedicated Right-Turn Lanes, Alternative 3: Mini Roundabout, and Alternative 4: Truck Route, are expected to decrease the crash rate compared to the No Build.
 - Although Alternative 2A and Alternative 4 are expected to decrease the crash rate, they are expected to increase the injury rate. These alternatives are expected to eliminate low-severity crash types which causes the injury rate to increase.
- Alternative 3: Mini Roundabout is expected to directly address pedestrian crashes and safety concerns at the intersection by providing traffic calming, two-stage pedestrian crossings, and shorter crossing distances.
 - Roundabouts are typically expected to increase rear-end and sideswipe crash types. However, the particular sideswipe safety issue at this intersection would essentially be eliminated with the construction of a roundabout.

Table 10. Safety Analysis Summary

	Alternative 0 (No Build)	Alternative 1 All-Way Stop	Alternative 2 Modified Signal Timing	Alternative 2A Modified Signal Timing + RTLs	Alternative 3 Mini Roundabout	Alternative 4 Truck Route
Observed/Estimated Crash Rate (Crashes/MEV)	0.52	0.52	0.52	0.39	0.32	0.40
Observed/Estimated Injury Crashes (Percent of Total Crashes)	39.3%	39.3%	39.3%	52.4%	24.5%	50.0%
2050 Estimated Crash Cost (2030 Dollars)	\$521,768	\$521,768	\$521,768	\$507,494	\$170,618	\$509,533

3.8 CONSTRUCTION COST ESTIMATES

High-level cost estimates were generated for the intersection alternatives based on a review of the site and previous project experience. The construction cost estimates are summarized in **Table 11**. These include a 30 percent contingency to account for risk or any unknowns that may not be identified without more detailed engineering. Construction cost estimates include 10 percent for professional service fees but exclude right-of way costs. Professional service fees include final design, plan specifications and estimates, construction administration, and any other work needed to facilitate construction. Further preliminary engineering is necessary to refine the construction cost estimates to accurately account for actual construction limits, grading, wetland impacts, drainage, and other design considerations, or to be suitable for project programming. The cost estimates shown are only intended to be used for the purpose of relative comparison within this ICE report. High-level construction cost estimates are included in **Appendix H**.

Table 11. Planning-Level Construct Cost Estimate Summary

Alternative	Construction Cost Estimate (2030 Dollars)
Alternative 1 All-Way Stop	\$10,000
Alternative 2 Modified Signal Timing	\$500,000
Alternative 2A Modified Signal Timing + RTLs	\$600,000
Alternative 3 Mini Roundabout	\$1,310,256
Alternative 4 Truck Route	\$10,000

During concept layout development it was determined that Alternative 2A: Modified Signal Timing + Dedicated Right-Turn Lanes is not feasible from a construction standpoint. Based on the existing intersection footprint, trucks would not be able to turn from the proposed right-turn lanes without either:

- Encroaching in other lanes on entry and exit, or
- By making geometric modifications that would require significant right of way and business impacts in each quadrant

Truck turning movements were also completed for Alternative 3: Mini Roundabout. Due to space constraints at the intersection, trucks will be required to drive over the splitter island on entry and approach of the proposed mini roundabout. Truck turning movements for Alternative 2A and Alternative 3 are included in **Appendix I**. Alternative 4: Truck Route could be implemented in combination with any of the alternatives to discourage truck traffic from using the intersection to continue east on US 169 / MN 210. However, it should be noted that implementing the proposed truck route would not eliminate 100 percent of truck traffic from the intersection, but it would significantly reduce truck turning movements, specifically the northbound right-turn and westbound left-turn movements.

3.9 BENEFIT/COST ANALYSIS

An economic benefit/cost analysis was completed in accordance with the MnDOT Office of Investment Management's *Benefit/Cost Analysis for Transportation Projects* procedures and assumes a 20-year analysis period. The benefit/cost ratio is a comparison between the estimated traffic operations and safety benefit for the intersection alternatives, the estimated construction cost, and any expected operational maintenance cost over this period (e.g. lighting, street signs). The highest benefit/cost ratio represents the most economically reactive solution. Benefit/cost ratios less than 1.0 may not be considered an economically viable alternative; however, they may be worth considering as a proactive long-term solution. At the end of the analysis period there is remaining capital value with each infrastructure component, which is also accounted for in the total cost. The 20-year traffic operation and safety benefit values are influenced by this decision and reflected in the benefit/cost ratio. The economic benefit/cost analysis for the intersection alternatives are summarized in **Table 12** and provided in detail in **Appendix J**.

Key findings of the benefit/cost analysis are listed below:

- All alternatives, except Alternative 2: Modified Signal Timing, are expected to have a positive B/C ratio greater than 1.0.
 - With a positive operational benefit and very low estimated construction cost, Alternative 1: All-Way Stop is expected to have a very high B/C. However, this alternative is not expected to have a positive impact on existing intersection safety.
 - Alternative 2: Modified Signal Timing is the only alternative with a negative operational benefit and a negative B/C ratio.
 - Alternative 4: Truck Route has the highest benefit/cost ratio of the alternatives (943.6). It should be noted that this alternative assumes that 100 percent of truck traffic will utilize the truck route.
- Alternative 1: All-Way Stop and Alternative 2: Modified Signal timing are not expected to have any impact on existing safety. All other alternatives are expected to have a positive safety benefit, with Alternative 3: Mini Roundabout, having the highest.

Table 12. Benefit/Cost Analysis Summary

	Alternative 1 All-Way Stop	Alternative 2 Modified Signal Timing	Alternative 2A Modified Signal Timing + RTLs	Alternative 3 Mini Roundabout	Alternative 4 Truck Route
Total Traffic Operation Benefit	\$ 5,521,373	\$ (2,055,889)	\$ 16,256,551	\$ 52,440,180	\$ 9,255,800
Total Safety Benefit	\$ -	\$ -	\$ 210,040	\$ 5,134,058	\$ 180,034
Total Cost ¹	\$ 10,000	\$ 500,000	\$ 600,000	\$ 852,886	\$ 10,000
Benefit to Cost Ratio	552.1	-4.1	27.4	67.5	943.6

¹Total cost is a 20-year estimate (2030-2050) that includes the discounted construction cost plus professional fees minus the remaining capital value at the end of the analysis period.

3.10 ALTERNATIVES EVALUATION MATRIX

A comparison matrix summarizing the key decision factors with respect to the project goals is provided in **Table 13**. The key decision-making factors include:

- **Pros and Cons** – Qualitative assessment of key advantages and disadvantages of the preferred intersection alternatives
- **Safety Evaluation** – Assessment of expected impact on motorist safety and the degree to which existing safety deficiency is improved
- **Traffic Operations Evaluation** – Documentation of anticipated future traffic operations
- **Economic Evaluation** – Construction cost estimates and benefit/cost ratios

Table 13. Alternatives Evaluation Matrix



Alternative	Concept Layout	Description	Pros and Cons	Expected Safety (10-Year Analysis)	Warrant Evaluation	Expected Operations	Benefit/Cost Analysis
No Build		The "No Build" alternative carries the current geometry and traffic control (traffic signal) forward without any changes to existing lane configuration	<p>Pros:</p> <ol style="list-style-type: none"> 1. No construction cost 2. No R/W acquisition 3. Traffic signal warrants are met under existing and forecast year traffic volumes <p>Cons:</p> <ol style="list-style-type: none"> 1. No improvement to known safety concerns 2. No improvement to future operation concerns 3. Ongoing maintenance and electricity costs 	<p>Fully or partially addressed known safety issues:</p> <p>None</p> <p>Unaddressed known safety issues:</p> <ol style="list-style-type: none"> 1. Sideswipes (9 of 28 existing) as a consequence of de facto right-turn lane use) 2. Left-turn crashes (6 of 28 existing) 3. Ped/bike crashes (5 of 28 existing) <p>Potential new safety issues:</p> <p>None</p>	<p>2025 Volumes</p> <ul style="list-style-type: none"> -Warrant 1 (8-hour): MET -Warrant 2 (4-hour): MET -Warrant 3 (peak hour): MET -Warrant 7 (crash history): not met <p>2030 Volumes</p> <ul style="list-style-type: none"> -Warrant 1 (8-hour): MET -Warrant 2 (4-hour): MET -Warrant 3 (peak hour): MET -Warrant 7 (crash history): not met <p>2050 Volumes</p> <ul style="list-style-type: none"> -Warrant 1 (8-hour): MET -Warrant 2 (4-hour): MET -Warrant 3 (peak hour): MET -Warrant 7 (crash history): not met 	<p>Intersection Overall Delay / LOS -- Worst Approach Delay / LOS:</p> <ul style="list-style-type: none"> - 24.8s / C -- 28.3s / C (2025 AM) - 26.7s / C -- 29.4s / C (2025 PM) - 56.2s / E -- 84.0s / F (2025 FRI) - 33.8s / C -- 43.1s / D (2025 SUN) <p>- 25.7s / C -- 29.5s / C (2030 AM)</p> <ul style="list-style-type: none"> - 29.8s / C -- 32.8s / C (2030 PM) - 81.2s / F -- 149.5s / F (2030 FRI) - 42.3s / D -- 61.7s / E (2030 SUN) <p>- 40.5s / D -- 55.4s / E (2050 AM)</p> <ul style="list-style-type: none"> - 55.5s / E -- 88.2s / F (2050 PM) - >300s / F -- >300s / F (2050 FRI) - 210.9s / F -- <300s / F (2050 SUN) 	<p>Operational Benefit:</p> <p>N/A</p> <p>Safety Benefit:</p> <p>N/A</p> <p>Total Cost:</p> <p>N/A</p> <p>B/C Ratio:</p> <p>N/A</p>
Alternative 1 All-Way Stop Control		This alternative replaces existing signalized traffic control with all-way stop control without any change to existing lane configuration	<p>Pros:</p> <ol style="list-style-type: none"> 1. May reduce angle and left-turn crashes 2. No R/W acquisition expected 3. Low cost <p>Cons:</p> <ol style="list-style-type: none"> 1. No improvement to known safety concerns 2. May potentially result in non-compliance or roll-throughs 3. Anticipated to increase mainline rear-end crashes; potentially severe angle and left-turn crashes due to non-compliance 4. Minimal improvement to overall intersection/worst approach delay 	<p>Fully or partially addressed known safety issues:</p> <ol style="list-style-type: none"> 1. Established right of way priority for vehicles and pedestrians 2. May positively improve (but not eliminate) angle and left-turn crashes <p>Unaddressed known safety issues:</p> <ol style="list-style-type: none"> 1. Sideswipes (9 of 28 existing) as a consequence of de facto right-turn lane use) <p>Potential new safety issues:</p> <ol style="list-style-type: none"> 1. Expect an increase in non compliance/rolling stops 2. Increase in mainline rear-end crashes 	<p>2025 Volumes</p> <ul style="list-style-type: none"> A: Signal Justified: MET B: Crash History: not met C1: Volume condition: MET C2: Delay condition: not met <p>2030 Volumes</p> <ul style="list-style-type: none"> A: Signal Justified: MET B: Crash History: not met C1: Volume condition: MET C2: Delay condition: MET <p>2050 Volumes</p> <ul style="list-style-type: none"> A: Signal Justified: MET B: Crash History: not met C1: Volume condition: MET C2: Delay condition: MET 	<p>Intersection Overall Delay / LOS -- Worst Approach Delay / LOS:</p> <ul style="list-style-type: none"> - 17.6s / C -- 27.5s / D (2025 AM) - 18.7s / C -- 28.0s / D (2025 PM) - 60.7s / F -- 95.2s / F (2025 FRI) - 25.6s / D -- 40.4s / E (2025 SUN) <p>- 19.2s / C -- 30.6s / D (2030 AM)</p> <ul style="list-style-type: none"> - 20.4s / C -- 30.1s / D (2030 PM) - 92.9s / F -- 165.0s / F (2030 FRI) - 30.8s / D -- 52.1s / F (2030 SUN) <p>- 34.6s / D -- 61.3s / F (2050 AM)</p> <ul style="list-style-type: none"> - 56.7s / F -- 89.8s / F (2050 PM) - >300s / F -- >300s / F (2050 FRI) - 176.9s / F -- <300s / F (2050 SUN) 	<p>Operational Benefit:</p> <p>\$5.5M</p> <p>Safety Benefit:</p> <p>N/A</p> <p>Total Cost:</p> <p>\$10,000</p> <p>B/C Ratio:</p> <p>552.1</p>
Alternative 2 Modified Signal Timing		This alternative replaces aging infrastructure with a new traffic signal system and optimizes signal timing, without any changes to existing lane configuration	<p>Pros:</p> <ol style="list-style-type: none"> 1. No R/W acquisition needed 2. Traffic signal warrants are met under existing and forecast year traffic volumes 3. Moderate cost <p>Cons:</p> <ol style="list-style-type: none"> 1. No improvement to known safety concerns 2. Although a minor improvement to worst approach delay is expected, no improvement to overall intersection delay is expected 3. Ongoing maintenance and electricity costs 	<p>Fully or partially addressed known safety issues:</p> <p>None</p> <p>Unaddressed known safety issues:</p> <ol style="list-style-type: none"> 1. Sideswipes (9 of 28 existing) as a consequence of de facto right-turn lane use) 2. Left-turn crashes (6 of 28 existing) 3. Ped/bike crashes (5 of 28 existing) <p>Potential new safety issues:</p> <p>None</p>	<p>2025 Volumes</p> <ul style="list-style-type: none"> -Warrant 1 (8-hour): MET -Warrant 2 (4-hour): MET -Warrant 3 (peak hour): MET -Warrant 7 (crash history): not met <p>2030 Volumes</p> <ul style="list-style-type: none"> -Warrant 1 (8-hour): MET -Warrant 2 (4-hour): MET -Warrant 3 (peak hour): MET -Warrant 7 (crash history): not met <p>2050 Volumes</p> <ul style="list-style-type: none"> -Warrant 1 (8-hour): MET -Warrant 2 (4-hour): MET -Warrant 3 (peak hour): MET -Warrant 7 (crash history): not met 	<p>Intersection Overall Delay / LOS -- Worst Approach Delay / LOS:</p> <ul style="list-style-type: none"> - 20.2s / C -- 27.4s / C (2025 AM) - 29.9s / C -- 33.3s / C (2025 PM) - 60.7s / E -- 77.6s / E (2025 FRI) - 35.6s / D -- 41.5s / D (2025 SUN) <p>- 28.2s / C -- 31.9s / C (2030 AM)</p> <ul style="list-style-type: none"> - 21.4s / C -- 34.9s / C (2030 PM) - 79.4s / E -- 100.0s / F (2030 FRI) - 43.2s / D -- 54.3s / D (2030 SUN) <p>- 45.7s / D -- 53.0s / D (2050 AM)</p> <ul style="list-style-type: none"> - 56.7s / E -- 64.9s / E (2050 PM) - >300s / F -- >300s / F (2050 FRI) - 178.7s / F -- <300s / F (2050 SUN) 	<p>Operational Benefit:</p> <p>\$2.1M</p> <p>Safety Benefit:</p> <p>N/A</p> <p>Total Cost:</p> <p>\$500,000</p> <p>B/C Ratio:</p> <p>4.1</p>

Table 13. Alternatives Evaluation Matrix (Continued)

Alternative	Concept Layout	Description	Pros and Cons	Expected Safety (10-Year Analysis)	Warrant Evaluation	Expected Operations	Benefit/Cost Analysis
Alternative 2A Modified Signal Timing + Dedicated Right-Turn Lanes		This alternative replaces aging infrastructure with a new traffic signal system and optimizes signal timing. Additionally, dedicated right-turn lanes will be constructed for each intersection approach	<p>Pros:</p> <ol style="list-style-type: none"> 1. Improve safety by mitigating sideswipes between trucks and cars that result from de facto right turn lane use 2. Moderate improvement to operations 3. Traffic signal warrants are met under existing and forecast year traffic volumes <p>Cons:</p> <ol style="list-style-type: none"> 1. Reconstructing intersection corners to provide dedicated right-turn lanes for all approaches would require significant building impacts 2. Loss of convenient parking for businesses 3. Does not address safety concerns with left-turn and ped/bike crashes 4. Improvements do not fully address future operational concerns 5. Ongoing maintenance and electricity costs 	<p>Fully or partially addressed known safety issues:</p> <ol style="list-style-type: none"> 1. Sideswipes (9 of 28 existing) as a consequence of de facto right-turn lane use) <p>Unaddressed known safety issues:</p> <ol style="list-style-type: none"> 1. Left-turn crashes (6 of 28 existing) 2. Ped/bike crashes (5 of 28 existing) <p>Potential new safety issues:</p> <p>None</p>	<p>2025 Volumes</p> <ul style="list-style-type: none"> -Warrant 1 (8-hour): MET -Warrant 2 (4-hour): MET -Warrant 3 (peak hour): MET -Warrant 7 (crash history): not met <p>2030 Volumes</p> <ul style="list-style-type: none"> -Warrant 1 (8-hour): MET -Warrant 2 (4-hour): MET -Warrant 3 (peak hour): MET -Warrant 7 (crash history): not met <p>2050 Volumes</p> <ul style="list-style-type: none"> -Warrant 1 (8-hour): MET -Warrant 2 (4-hour): MET -Warrant 3 (peak hour): MET -Warrant 7 (crash history): not met 	<p>Intersection Overall Delay / LOS --</p> <p>Worst Approach Delay / LOS:</p> <ul style="list-style-type: none"> - 17.8s / B -- 24.8s / C (2025 AM) - 25.0s / C -- 25.9s / C (2025 PM) - 37.3s / D -- 43.4s / D (2025 FRI) - 27.3s / C -- 30.8s / C (2025 SUN) <p>- 23.5s / C -- 26.1s / C (2030 AM)</p> <p>- 26.5s / C -- 27.8s / C (2030 PM)</p> <p>- 39.3s / D -- 44.9s / D (2030 FRI)</p> <p>- 29.5s / C -- 34.2s / C (2030 SUN)</p> <p>- 32.0s / C -- 37.9s / D (2050 AM)</p> <p>- 38.1s / D -- 43.5s / D (2050 PM)</p> <p>- 191.8s / F -- 290.5s / F (2050 FRI)</p> <p>- 57.0s / E -- 94.1s / F (2050 SUN)</p>	<p>Operational Benefit:</p> <p>\$16.3M</p> <p>Safety Benefit:</p> <p>\$210,000</p> <p>Total Cost:</p> <p>\$600,000</p> <p>B/C Ratio:</p> <p>27.4</p>
Alternative 3 Mini Roundabout		This alternative constructs a mini-roundabout at the intersection	<p>Pros:</p> <ol style="list-style-type: none"> 1. Improve safety by mitigating frequency and severity of ped/bike crashes 2. Effectively eliminates angle and left-turn crashes 3. Effectively eliminates existing sideswipe safety issue caused by defacto right-turn lane use, without impacts to adjacent buildings 4. Provides traffic calming and two-stage crossing for pedestrians 5. Expected to significantly improve overall intersection and side-street delay under all volume scenarios 6. No R/W acquisition expected <p>Cons:</p> <ol style="list-style-type: none"> 1. May increase frequency of rear-end and sideswipe crashes 2. High cost 3. Special design for trucks - trucks will be required to mount the entering and exiting splitter islands in order to complete their movement 	<p>Fully or partially addressed known safety issues:</p> <ol style="list-style-type: none"> 1. Sideswipes (9 of 28 existing) as a consequence of de facto right-turn lane use) 2. Left-turn crashes (6 of 28 existing) 3. Ped/bike crashes (5 of 28 existing) <p>Unaddressed known safety issues:</p> <p>None</p> <p>Potential new safety issues:</p> <p>None</p>	<p>A single-lane roundabout is expected to accommodate peak hour traffic volumes under existing and forecast volume scenarios</p>	<p>Intersection Overall Delay / LOS --</p> <p>Worst Approach Delay / LOS:</p> <ul style="list-style-type: none"> - 2.1s / A -- 2.5s / A (2025 AM) - 2.9s / A -- 3.4s / A (2025 PM) - 4.0s / A -- 5.0s / A (2025 FRI) - 2.9s / A -- 3.6s / A (2025 SUN) <p>- 2.3s / A -- 2.7s / A (2030 AM)</p> <p>- 3.1s / A -- 3.6s / A (2030 PM)</p> <p>- 4.5s / A -- 5.8s / A (2030 FRI)</p> <p>- 3.2s / A -- 4.0s / A (2030 SUN)</p> <p>- 3.0s / A -- 3.6s / A (2050 AM)</p> <p>- 4.5s / A -- 5.2s / A (2050 PM)</p> <p>- 7.6s / A -- 9.8s / A (2050 FRI)</p> <p>- 5.0s / A -- 5.9s / A (2050 SUN)</p>	<p>Operational Benefit:</p> <p>\$52.4M</p> <p>Safety Benefit:</p> <p>\$5.1M</p> <p>Total Cost:</p> <p>\$850,000</p> <p>B/C Ratio:</p> <p>67.5</p>
Alternative 4 Truck Route		This alternative designates a specific route for trucks without using the US 169 & MN 210 intersection. The truck route would be promoted by signing, and would utilize MN 47 and CSAH 12 to route around the study intersection	<p>Pros:</p> <ol style="list-style-type: none"> 1. Effectively eliminates existing sideswipe safety issue by re-routing trucks, without impacts to adjacent buildings 2. Significant improvement to intersection operations 3. Can be implemented in combination with any of the other intersection improvement alternatives 4. No R/W acquisition expected 5. Low cost <p>Cons:</p> <ol style="list-style-type: none"> 1. Improvement to safety and operations are estimated assuming that 100 percent of existing truck volume will re-route 2. Coordination with local agencies and stakeholders (residents along MN 47 and CSAH 12) would be required before implementing a truck route 3. Potential pavement and intersection improvements along the proposed truck route would need to be evaluated before implementation 	<p>Fully or partially addressed known safety issues:</p> <ol style="list-style-type: none"> 1. Sideswipes (9 of 28 existing) as a consequence of de facto right-turn lane use) <p>Unaddressed known safety issues:</p> <ol style="list-style-type: none"> 1. Left-turn crashes (6 of 28 existing) 2. Ped/bike crashes (5 of 28 existing) <p>Potential new safety issues:</p> <p>None</p>	<p>N/A</p>	<p>Intersection Overall Delay / LOS --</p> <p>Worst Approach Delay / LOS:</p> <ul style="list-style-type: none"> - 21.4s / C -- 23.7s / C (2025 AM) - 26.2s / C -- 28.2s / C (2025 PM) - 41.8s / D -- 56.0s / E (2025 FRI) - 31.9s / C -- 41.7s / D (2025 SUN) <p>- 24.8s / C -- 28.6s / C (2030 AM)</p> <p>- 26.9s / C -- 29.9s / C (2030 PM)</p> <p>- 49.1s / D -- 70.2s / E (2030 FRI)</p> <p>- 41.1s / D -- 60.1s / E (2030 SUN)</p> <p>- 29.8s / C -- 36.1s / D (2050 AM)</p> <p>- 51.0s / D -- 65.3s / E (2050 PM)</p> <p>- 262.9s / F -- >300s / F (2050 FRI)</p> <p>- 189.0s / F -- <300s / F (2050 SUN)</p>	<p>Operational Benefit:</p> <p>\$9.3M</p> <p>Safety Benefit:</p> <p>\$180,000</p> <p>Total Cost:</p> <p>\$10,000</p> <p>B/C Ratio:</p> <p>943.6</p>

4. CONCLUSIONS AND RECOMMENDATIONS

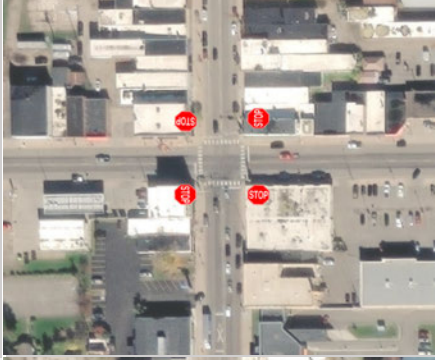
Recommendations for the US 169 and MN 210 (W JCT) intersection are made based upon discussions with MnDOT District 3 and local agencies, results of the intersection operations and safety analysis, results of the benefit-cost analysis, and consideration of key decision factors presented in this report. Based on the information presented in this ICE, a mini roundabout is recommended at the intersection.

Alternative 1: All-Way Stop and Alternative 2: Modified Signal Timing are not viable intersection alternatives because they are not expected to improve intersection safety, which is a primary goal of this study. Although Alternative 2A: Modified Signal Timing + Dedicated Right-Turn Lanes is expected to have a safety improvement, this alternative is not feasible from a construction standpoint. Based on the existing intersection footprint, trucks would not be able to turn from the proposed right-turn lanes without either encroaching in other lanes on entry and exit, or by making geometric modifications that would require significant right of way and business impacts in each quadrant. Alternative 3: Mini Roundabout is expected to provide the following benefits:

- A mini roundabout is the only alternative that is expected to significantly improve both overall intersection and worst approach operations, even during weekend peaks into forecast year 2050
- Traffic calming
- Significant improvement for pedestrians – downtown Aitkin attracts substantial pedestrian volumes, specifically during the summer months. A mini roundabout will provide a two-stage crossing for pedestrians and will decrease the total crossing distance
- Can be constructed within the existing intersection footprint with none to minimal right of way impacts

Alternative 4: Truck Route resulted in the highest benefit/cost ratio of the alternatives due to its positive operational and safety benefits combined with an extremely low construction cost estimate. Although the benefit/cost ratio for this alternative is high, it is not expected to have as significant of an impact to safety and operations as Alternative 3: Mini Roundabout. Specifically, the truck route alternative is not expected to improve pedestrian safety.

It should be noted that due to space constraints, trucks will be required to drive over the splitter islands on entry and exit of the mini roundabout. If Alternative 3: Mini Roundabout and Alternative 4: Truck Route were implemented together to minimize the number of trucks utilizing the intersection, vehicles and pedestrians could navigate the intersection more comfortably, and splitter islands would require less maintenance over time. Alternative 4: Truck Route could be considered for implementation with the proposed Alternative 3: Mini Roundabout. Coordination with local agencies and stakeholders, as well as an evaluation of existing pavement condition and intersection safety along the proposed truck route, would be needed prior to implementation.

5. APPENDICES

- A. Turning Movement Counts
- B. Traffic Forecasting Results
- C. Existing & No Build Detailed MOE
- D. Signal Warrant Analysis Results
- E. Roundabout Capacity Analysis Results
- F. Intersection Alternatives Detailed MOE
- G. Safety Analysis Results
- H. Detailed Cost Estimates
- I. Truck Turning Movements
- J. Benefit/Cost Analysis Results

APPENDIX A: TURNING MOVEMENT COUNTS

ALLIANT ENGINEERING, INC.

733 S Marquette Ave #700, Minneapolis, MN 55402

Intersection: US 169 & MN 210 (W Jct)
 Date: 5/7/2025
 Duration: 0000-2400

Site Code: 200
 Ref Pt: N/A
 Page No: 1 of 5

All Vehicles (Cars & Trucks) Printed

Start Time	Minnesota Avenue Southbound						MN 210 Westbound						US 169 Northbound						MN 210 Eastbound						Int. Veh. Total	Int. Ped/ Bike Total	
	U-Turn	Left	Thru	Right	App. Total	Peds/ Bikes	U-Turn	Left	Thru	Right	App. Total	Peds/ Bikes	U-Turn	Left	Thru	Right	App. Total	Peds/ Bikes	U-Turn	Left	Thru	Right	App. Total	Peds/ Bikes			
0:00	--	--	--	1	1	--	--	--	--	3	3	--	--	--	--	--	0	--	--	1	1	--	2	--	6	--	
0:15	--	--	--	2	2	--	--	--	2	2	4	--	--	--	1	--	1	--	--	2	2	--	2	--	9	--	
0:30	--	--	--	2	2	--	--	--	3	--	3	--	--	--	--	--	0	--	--	1	2	--	3	--	8	--	
0:45	--	1	--	1	2	--	--	1	1	1	3	--	--	--	--	--	0	--	--	1	1	--	2	--	7	--	
Hour Total	--	1	--	6	7	--	--	1	6	6	13	--	--	--	1	--	1	--	--	3	6	--	9	--	30	--	
1:00	--	--	--	1	1	--	--	--	1	--	1	--	--	--	--	--	0	--	--	--	1	--	1	--	3	--	
1:15	--	--	--	--	0	--	--	--	4	1	5	--	--	--	--	--	0	--	--	1	1	--	2	--	7	--	
1:30	--	--	--	--	0	--	--	--	2	1	3	--	--	--	--	--	0	--	--	1	1	--	2	--	5	--	
1:45	--	1	--	--	1	--	--	1	3	--	4	--	--	--	--	--	0	--	--	--	--	--	0	--	5	--	
Hour Total	--	1	--	1	2	--	--	1	10	2	13	--	--	--	--	--	--	--	--	2	3	--	5	--	20	--	
2:00	--	1	--	1	2	--	--	--	1	--	1	--	--	--	--	--	0	--	--	3	2	--	5	--	8	--	
2:15	--	--	--	--	0	--	--	--	--	--	0	--	--	--	--	--	0	--	--	--	3	--	3	--	3	--	
2:30	--	1	--	--	1	--	--	--	1	--	1	--	--	--	--	--	0	--	--	--	1	--	1	--	3	--	
2:45	--	--	--	--	0	--	--	--	3	--	3	--	--	--	--	--	0	--	--	--	--	--	0	--	3	--	
Hour Total	--	2	--	1	3	--	--	--	5	--	5	--	--	--	--	--	--	--	--	3	6	--	9	--	17	--	
3:00	--	1	--	--	1	--	--	--	1	1	2	--	--	--	1	--	1	--	--	--	1	--	1	--	5	--	
3:15	--	--	--	--	0	--	--	--	1	--	1	--	--	--	2	--	2	--	--	--	1	--	1	--	4	--	
3:30	--	--	--	1	1	--	--	--	--	--	0	--	--	1	--	--	1	--	--	--	--	--	0	--	2	--	
3:45	--	--	--	1	1	--	--	--	--	3	3	--	--	--	--	--	0	--	--	1	1	--	2	--	6	--	
Hour Total	--	1	--	2	3	--	--	--	2	4	6	--	--	--	1	3	4	--	--	1	2	1	4	--	17	--	
4:00	--	--	1	--	1	--	--	--	4	1	5	--	--	--	1	--	1	--	--	1	2	--	3	--	10	--	
4:15	--	--	--	2	2	--	--	--	7	2	9	1	--	--	1	1	2	--	--	1	4	--	5	--	18	1	
4:30	--	2	--	1	3	--	--	--	8	--	8	--	--	1	--	--	1	--	--	5	2	--	7	--	19	--	
4:45	--	--	3	2	5	--	--	--	3	1	4	--	--	--	1	--	1	--	--	1	7	--	8	--	18	--	
Hour Total	--	2	4	5	11	--	--	--	22	4	26	1	--	--	1	3	1	5	--	8	15	--	23	--	65	1	
5:00	--	2	--	2	4	--	--	--	4	2	6	--	--	--	1	--	1	--	--	2	8	--	10	--	21	--	
5:15	--	5	1	5	11	--	--	--	8	4	12	1	--	--	1	2	--	3	--	3	10	--	13	--	39	1	
5:30	--	7	2	6	15	--	--	--	15	7	22	1	--	--	1	5	4	10	--	3	15	--	18	--	65	1	
5:45	--	5	4	2	11	--	--	--	18	17	35	--	--	--	2	5	2	9	--	4	16	--	20	--	75	--	
Hour Total	--	19	7	15	41	--	--	--	45	30	75	2	--	--	4	12	7	23	--	12	49	--	61	--	200	2	
6:00	--	10	1	8	19	--	--	--	8	11	19	--	--	--	3	3	6	--	--	8	23	--	31	--	75	--	
6:15	--	13	3	7	23	--	--	--	1	17	13	31	--	--	6	4	2	12	--	--	8	20	2	30	--	96	--
6:30	--	9	4	8	21	--	--	--	3	19	15	37	--	--	3	5	2	10	--	--	9	20	4	33	--	101	--
6:45	--	17	2	9	28	--	--	--	--	29	20	49	--	--	1	9	3	13	--	--	23	28	4	55	--	145	--
Hour Total	--	49	10	32	91	--	--	--	4	73	59	136	--	--	10	21	10	41	--	--	48	91	10	149	--	417	--
7:00	--	10	8	8	26	--	--	--	2	35	26	63	--	--	1	14	3	18	--	--	12	31	4	47	--	154	--
7:15	--	21	16	14	51	--	--	--	4	28	35	67	1	--	3	15	5	23	--	--	13	40	5	58	--	199	1
7:30	--	23	22	10	55	--	--	--	5	43	33	81	--	--	3	14	3	20	--	--	18	52	11	81	--	237	--
7:45	--	24	40	15	79	--	--	--	3	43	44	90	--	--	5	33	8	46	--	--	24	53	9	86	--	301	--
Hour Total	--	78	86	47	211	--	--	--	14	149	138	301	1	--	12	76	19	107	--	--	67	176	29	272	--	891	1
8:00	--	29	42	19	90	2	--	--	3	40	26	69	1	--	6	44	3	53	--	--	19	63	10	92	--	304	3
8:15	--	13	12	16	41	--	--	--	6	48	25	79	1	--	9	27	4	40	1	--	15	42	6	63	--	223	2
8:30	--	18	16	23	57	--	--	--	2	30	20	52	--	--	9	9	2	20	--	--	18	40	3	61	--	190	--
8:45	--	17	13	11	41	--	--	--	1	38	21	60	--	--	9	17	5	31	--	--	20	51	9	80	--	212	--
Hour Total	--	77	83	69	229	2	--	--	12	156	92	260	2	--	33	97	14	144	1	--	72	196	28	296	--	929	5
9:00	--	17	25	29	71	--	--	--	2	47	20	69	--	--	3	18	6	27	--	--	31	47	6	84	--	251	--
9:15	--	30	14	26	70	1	--	--	6	26	18	50	1	--	9	14	4	27	1	--	32	43	9	84	3	231	6
9:30	--	15	11	23	49	1	--	--	6	34	17	57	1	--	8	14	5	27	--	--	31	45	9	85	1	218	3
9:45	--	21	16	23	60	--	--	--	6	46	21	73	--	--	8	15	8	31	--	--	29	35	8	72	--	236	--
Hour Total	--	83	66	101	250	2	--	--	20	153	76	249	2	--	28	61	23	112	1	--	123	170	32	325	4	936	9
10:00	--	21	24	20	65	--	--	--	4	50	20	74	--	--	9	16	3	28	1	--	31	55	5	91	--	258	1
10:15	--	25	23	31	79	--	--	--	6	37	19	62	--	--	9	19	4	32	--	--	20	55	6	81	1	254	1
10:30	--	14	17	21	52	--	--	--	2	36	19	57	--	--	6	20	3	29	1	--	35	56	7	98	--	236	1
10:45	--	16	21	27	64	--	--	--	2	46	24	72	--	--	3	31	5	39	--	--	28	57	7	92	--	267	--
Hour Total	--	76	85	99	260	--	--	--	14	169	82	265	--	--	27	86	15	128	2	--	114	223	25	362	1	1015	3
11:00	--	22	27	29	78	--	--	--	7	43	24	74	--	--	5	19	11	35	--	--	31	39	10	80	1	267	1
11:15	--	15	20	24	59	1	--	--	7	52	22	81	--	--	5	23	8	36	--	--	25	40	8	73	1	249	2
11:30	--	25	19	21	65	1	--	--	4	41	25	70	1	--	5	18	6	29	--	--	23	44	21	88	--	252	2
11:45	--	22	18	17	57	--	--	--	4	49	26	79	2	--	10	18	7	35	1	--	29	50	7	86	--	257	3
Hour Total	--	84	84	91	259	2	--	--	22	185	97	304	3	--	25	78	32	135	1	--	108	173	46	327	2	1025	8
12:00	--	22	21	28	71	1	--	--	11	51	26	88	--	--	12	28	8	48	--	--	29	47	5	81	1	288	2
12:15	--	23	17	22	62	1	--	--	4	62	25	91	1	--	8	18	6	32	1	--	26	56	9	91	--	276	3
12:30	--	20	8	30	58	2	--	--	10	42	31	83	2	--	8	14	3	25	1	--	29	42	9	80	1	246	6
12:45	--	18	20	24	62	--	--	--	5	59	17	81	--	--	6	29	7	42	--	--	33	41	8	82	1	267	1
Hour Total	--	83	66	104	253	4	--	--	30	214	99	343	3	--	34	89	24	147	2	--	117	186	31	334	3	1077	12
13:00	--	22	22	23	67	--	--	--	7	47	22	76	--	--	5	20	4	29	2	--	25	45	5	75	--	247	2
13:15	--	22	17	29	68	--	--	--	3	43	18	64	--	--	8	15	6	29	1	--	27	38	7	72	2	233	3
13:30	--	25	25	30	80	--	--	--	10	48	29	87	3	--	6	16	6	28	4	--	18	41	9	68	1	263	8
13:45	--	15	20																								

Hour Total	--	72	70	98	240	--	--	22	175	87	284	2	--	34	114	23	171	2	--	108	179	23	310	3	1005	7
15:00	--	24	26	18	68	3	--	2	50	28	80	3	--	8	22	3	33	1	--	32	46	2	80	1	261	8
15:15	--	34	33	32	99	2	--	6	54	23	83	4	--	10	30	8	48	1	--	22	46	5	73	2	303	9
15:30	--	28	31	23	82	4	--	4	62	28	94	6	--	11	37	6	54	7	--	27	49	6	82	1	312	18
15:45	--	31	14	20	65	2	--	11	62	32	105	2	--	11	18	9	38	1	--	27	64	1	92	3	300	8
Hour Total	--	117	104	93	314	11	--	23	228	111	362	15	--	40	107	26	173	10	--	108	205	14	327	7	1176	43
16:00	--	33	17	25	75	3	--	7	63	31	101	1	--	8	21	7	36	--	--	23	52	5	80	4	292	8
16:15	--	29	22	24	75	--	--	4	62	34	100	--	--	4	23	7	34	--	--	26	42	11	79	2	288	2
16:30	--	30	18	19	67	--	--	8	76	36	120	2	--	7	28	7	42	1	--	27	54	16	97	2	326	5
16:45	--	32	23	27	82	1	--	4	60	27	91	1	--	6	18	2	26	1	--	24	66	2	92	--	291	3
Hour Total	--	124	80	95	299	4	--	23	261	128	412	4	--	25	90	23	138	2	--	100	214	34	348	8	1197	18
17:00	--	30	20	28	78	--	--	5	41	39	85	--	--	12	30	9	51	--	--	22	53	6	81	--	295	--
17:15	--	18	19	19	56	1	--	7	48	25	80	--	--	8	24	1	33	2	--	15	44	4	63	--	232	3
17:30	--	17	13	17	47	--	--	5	43	22	70	--	--	2	18	2	22	--	--	26	45	9	80	2	219	2
17:45	--	14	14	20	48	--	--	6	35	18	59	--	--	5	19	3	27	4	--	20	30	6	56	2	190	6
Hour Total	--	79	66	84	229	1	--	23	167	104	294	--	--	27	91	15	133	6	--	83	172	25	280	4	936	11
18:00	--	15	17	19	51	--	--	1	41	15	57	3	--	4	15	5	24	--	--	19	30	5	54	--	186	3
18:15	--	18	11	12	41	1	--	5	24	16	45	1	--	4	14	4	22	1	--	15	20	7	42	--	150	3
18:30	--	17	14	21	52	--	--	--	31	15	46	--	--	2	10	--	12	--	--	19	31	3	53	--	163	--
18:45	--	15	21	12	48	--	--	2	20	20	42	--	--	5	7	3	15	1	--	12	38	7	57	1	162	2
Hour Total	--	65	63	64	192	1	--	8	116	66	190	4	--	15	46	12	73	2	--	65	119	22	206	1	661	8
19:00	--	12	22	19	53	--	--	1	31	12	44	1	--	7	14	--	21	--	--	12	23	7	42	--	160	1
19:15	--	5	6	7	18	--	--	--	16	10	26	1	--	2	13	1	16	--	--	17	13	1	31	--	91	1
19:30	--	17	10	15	42	--	--	2	20	10	32	1	--	3	11	1	15	--	--	13	24	6	43	--	132	1
19:45	--	14	11	17	42	--	--	--	16	10	26	1	--	1	9	2	12	--	--	10	11	5	26	--	106	1
Hour Total	--	48	49	58	155	--	--	3	83	42	128	4	--	13	47	4	64	--	--	52	71	19	142	--	489	4
20:00	--	7	11	14	32	--	--	--	22	9	31	--	--	3	6	1	10	--	--	3	14	1	18	--	91	--
20:15	--	8	3	6	17	--	--	2	8	18	28	--	--	3	5	1	9	1	--	6	13	2	21	--	75	1
20:30	--	5	4	14	23	--	--	4	15	7	26	--	--	1	6	3	10	--	--	5	17	3	25	1	84	1
20:45	--	3	3	4	10	--	--	3	16	12	31	1	--	3	4	1	8	--	--	12	14	2	28	--	77	1
Hour Total	--	23	21	38	82	--	--	9	61	46	116	1	--	10	21	6	37	1	--	26	58	8	92	1	327	3
21:00	--	4	7	6	17	--	--	2	15	6	23	--	--	5	7	--	12	--	--	5	6	3	14	--	66	--
21:15	--	7	--	5	12	--	--	--	11	2	13	--	--	--	4	--	4	--	--	5	4	1	10	--	39	--
21:30	--	5	6	4	15	1	--	1	9	2	12	--	--	--	2	1	3	1	--	4	7	1	12	--	42	2
21:45	--	4	5	3	12	1	--	1	23	11	35	--	--	13	34	--	47	--	--	4	16	1	21	--	115	1
Hour Total	--	20	18	18	56	2	--	4	58	21	83	--	--	18	47	1	66	1	--	18	33	6	57	--	262	3
22:00	--	3	1	--	4	--	--	3	7	6	16	--	--	3	4	--	7	--	--	1	9	--	10	--	37	--
22:15	--	4	2	5	11	--	--	1	10	6	17	--	--	--	--	1	1	--	--	2	3	2	7	--	36	--
22:30	--	4	4	3	11	--	--	--	10	--	10	--	--	--	--	--	0	--	--	4	3	--	7	--	28	--
22:45	--	1	--	3	4	--	--	--	6	1	7	--	--	1	2	--	3	2	--	--	7	--	7	--	21	2
Hour Total	--	12	7	11	30	--	--	4	33	13	50	--	--	4	6	1	11	2	--	7	22	2	31	--	122	2
23:00	--	3	--	1	4	--	--	1	4	3	8	--	--	--	--	--	0	--	--	--	3	--	3	--	15	--
23:15	--	--	4	--	4	--	--	--	3	4	7	--	--	--	--	--	0	--	--	1	3	--	4	--	15	--
23:30	--	--	1	1	2	--	--	--	--	--	0	--	--	--	--	--	0	--	--	2	2	--	4	--	6	--
23:45	--	1	1	--	2	--	--	1	3	1	5	1	--	--	--	1	1	--	--	2	4	--	6	--	14	1
Grand Total	--	1204	1059	1238	3501	31	--	261	2562	1407	4230	51	--	386	1175	279	1840	40	--	1357	2546	383	4286	37	13857	159
% of App.	0.0%	34.4%	30.2%	35.4%			0.0%	6.2%	60.6%	33.3%			0.0%	21.0%	63.9%	15.2%			0.0%	31.7%	59.4%	8.9%				
% of Total	0.0%	8.7%	7.6%	8.9%	25.3%	19.5%	0.0%	1.9%	18.5%	10.2%	30.5%	32.1%	0.0%	2.8%	8.5%	2.0%	13.3%	25.2%	0.0%	9.8%	18.4%	2.8%	30.9%	23.3%		
Cars Total	--	1171	1024	1187	3382	31	--	249	2333	1372	3954	49	--	376	1131	272	1779	39	--	1275	2331	380	3986	37	13101	156
Cars % of Movement	0.0%	97.3%	96.7%	95.9%	96.6%	19.9%	0.0%	95.4%	91.1%	97.5%	93.5%	31.4%	0.0%	97.4%	96.3%	97.5%	96.7%	25.0%	0.0%	94.0%	91.6%	99.2%	93.0%	23.7%	94.5%	
Trucks Total	--	33	35	51	119	--	--	12	229	35	276	2	--	10	44	7	61	1	--	82	215	3	300	--	756	3
Trucks % of Movement	0.0%	2.7%	3.3%	4.1%	3.4%	0.0%	0.0%	4.6%	8.9%	2.5%	6.5%	66.7%	0.0%	2.6%	3.7%	2.5%	3.3%	33.3%	0.0%	6.0%	8.4%	0.8%	7.0%	0.0%	5.5%	

ALLIANT ENGINEERING, INC.

733 S Marquette Ave #700, Minneapolis, MN 55402

Intersection: US 169 & MN 210 (W Jct)
 Date: 5/7/2025
 Duration: 0000-2400

Site Code: 200
 Ref Pt: N/A
 Page No: 3 of 5

All Vehicles (Cars & Trucks) Printed

Start Time	Minnesota Avenue Southbound						MN 210 Westbound						US 169 Northbound						MN 210 Eastbound						Int. Veh. Total	Int. Ped/Bike Total
	U-Turn	Left	Thru	Right	App. Total	Peds/Bikes	U-Turn	Left	Thru	Right	App. Total	Peds/Bikes	U-Turn	Left	Thru	Right	App. Total	Peds/Bikes	U-Turn	Left	Thru	Right	App. Total	Peds/Bikes		
7:30	--	23	22	10	55	--	--	5	43	33	81	--	--	3	14	3	20	--	--	18	52	11	81	--	237	--
7:45	--	24	40	15	79	--	--	3	43	44	90	--	--	5	33	8	46	--	--	24	53	9	86	--	301	--
8:00	--	29	42	19	90	2	--	3	40	26	69	1	--	6	44	3	53	--	--	19	63	10	92	--	304	3
8:15	--	13	12	16	41	--	--	6	48	25	79	1	--	9	27	4	40	1	--	15	42	6	63	--	223	2
Hour Total	--	89	116	60	265	2	--	17	174	128	319	2	--	23	118	18	159	1	--	76	210	36	322	--	1065	5
% of App.	0.0%	33.6%	43.8%	22.6%			0.0%	5.3%	54.5%	40.1%			0.0%	14.5%	74.2%	11.3%			0.0%	23.6%	65.2%	11.2%				
% of Total	0.0%	8.4%	10.9%	5.6%	24.9%	40.0%	0.0%	1.6%	16.3%	12.0%	30.0%	40.0%	0.0%	2.2%	11.1%	1.7%	14.9%	20.0%	0.0%	7.1%	19.7%	3.4%	30.2%	0.0%		
Cars Total	--	86	107	54	247	2	--	16	153	125	294	2	--	22	99	18	139	1	--	74	195	36	305	--	985	5
Cars % of Movement	0.0%	96.6%	92.2%	90.0%	93.2%	40.0%	0.0%	94.1%	87.9%	97.7%	92.2%	40.0%	0.0%	95.7%	83.9%	100%	87.4%	20.0%	0.0%	97.4%	92.9%	100%	94.7%	0.0%	92.5%	
Trucks Total	--	3	9	6	18	--	--	1	21	3	25	--	--	1	19	--	20	--	--	2	15	--	17	--	80	--
Trucks % of Movement	0.0%	3.4%	7.8%	10.0%	6.8%	--	0.0%	5.9%	12.1%	2.3%	7.8%	--	0.0%	4.3%	16.1%	0.0%	12.6%	--	0.0%	2.6%	7.1%	0.0%	5.3%	--	7.5%	

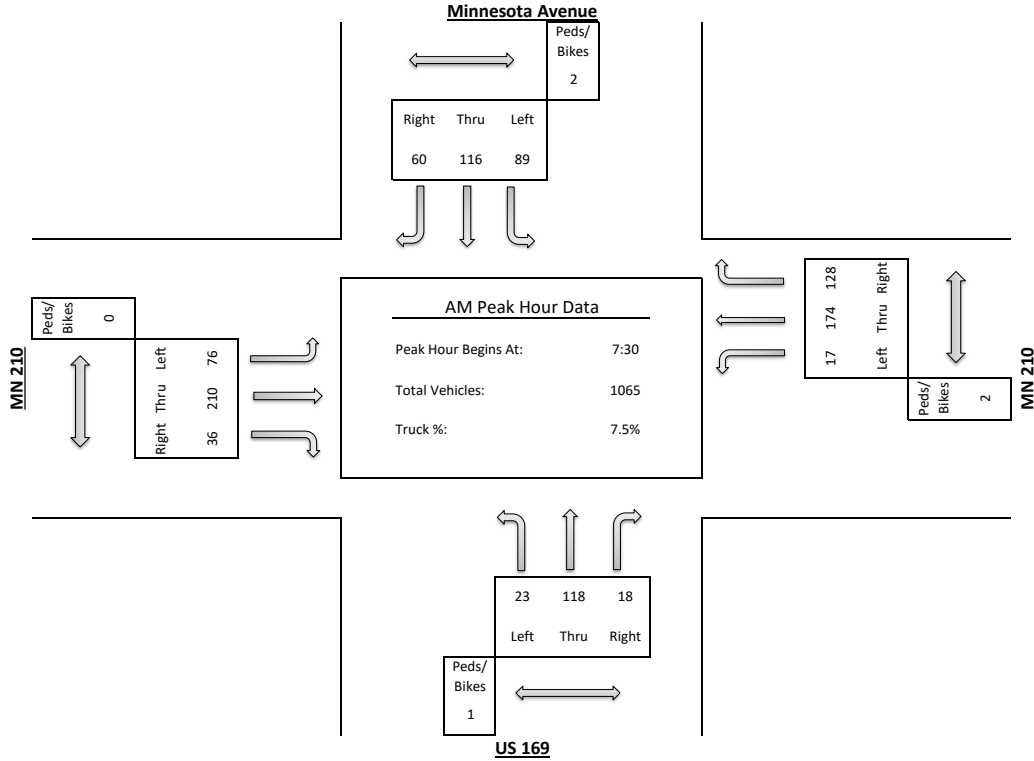

ALLIANT ENGINEERING, INC.

733 S Marquette Ave #700, Minneapolis, MN 55402

Intersection: US 169 & MN 210 (W Jct)
 Date: 5/7/2025
 Duration: 0000-2400

Site Code: 200
 Ref Pt: N/A
 Page No: 4 of 5

All Vehicles (Cars & Trucks) Printed

Start Time	Minnesota Avenue Southbound						MN 210 Westbound						US 169 Northbound						MN 210 Eastbound						Int. Veh. Total	Int. Ped/Bike Total
	U-Turn	Left	Thru	Right	App. Total	Peds/Bikes	U-Turn	Left	Thru	Right	App. Total	Peds/Bikes	U-Turn	Left	Thru	Right	App. Total	Peds/Bikes	U-Turn	Left	Thru	Right	App. Total	Peds/Bikes		
12:00	--	22	21	28	71	1	--	11	51	26	88	--	--	12	28	8	48	--	--	29	47	5	81	1	288	2
12:15	--	23	17	22	62	1	--	4	62	25	91	1	--	8	18	6	32	1	--	26	56	9	91	--	276	3
12:30	--	20	8	30	58	2	--	10	42	31	83	2	--	8	14	3	25	1	--	29	42	9	80	1	246	6
12:45	--	18	20	24	62	--	--	5	59	17	81	--	--	6	29	7	42	--	--	33	41	8	82	1	267	1
Hour Total	--	83	66	104	253	4	--	30	214	99	343	3	--	34	89	24	147	2	--	117	186	31	334	3	1077	12
% of App.	0.0%	32.8%	26.1%	41.1%			0.0%	8.7%	62.4%	28.9%			0.0%	23.1%	60.5%	16.3%			0.0%	35.0%	55.7%	9.3%				
% of Total	0.0%	7.7%	6.1%	9.7%	23.5%	33.3%	0.0%	2.8%	19.9%	9.2%	31.8%	25.0%	0.0%	3.2%	8.3%	2.2%	13.6%	16.7%	0.0%	10.9%	17.3%	2.9%	31.0%	25.0%		
Cars Total	--	81	65	102	248	4	--	30	193	98	321	3	--	33	87	24	144	2	--	108	166	31	305	3	1018	12
Cars % of Movement	0.0%	97.6%	98.5%	98.1%	98.0%	33.3%	0.0%	100%	90.2%	99.0%	93.6%	25.0%	0.0%	97.1%	97.8%	100%	98.0%	16.7%	0.0%	92.3%	89.2%	100%	91.3%	25.0%	94.5%	
Trucks Total	--	2	1	2	5	--	--	--	21	1	22	--	--	1	2	--	3	--	--	9	20	--	29	--	59	--
Trucks % of Movement	0.0%	2.4%	1.5%	1.9%	2.0%	--	0.0%	0.0%	9.8%	1.0%	6.4%	--	0.0%	2.9%	2.2%	0.0%	2.0%	--	0.0%	7.7%	10.8%	0.0%	8.7%	--	5.5%	

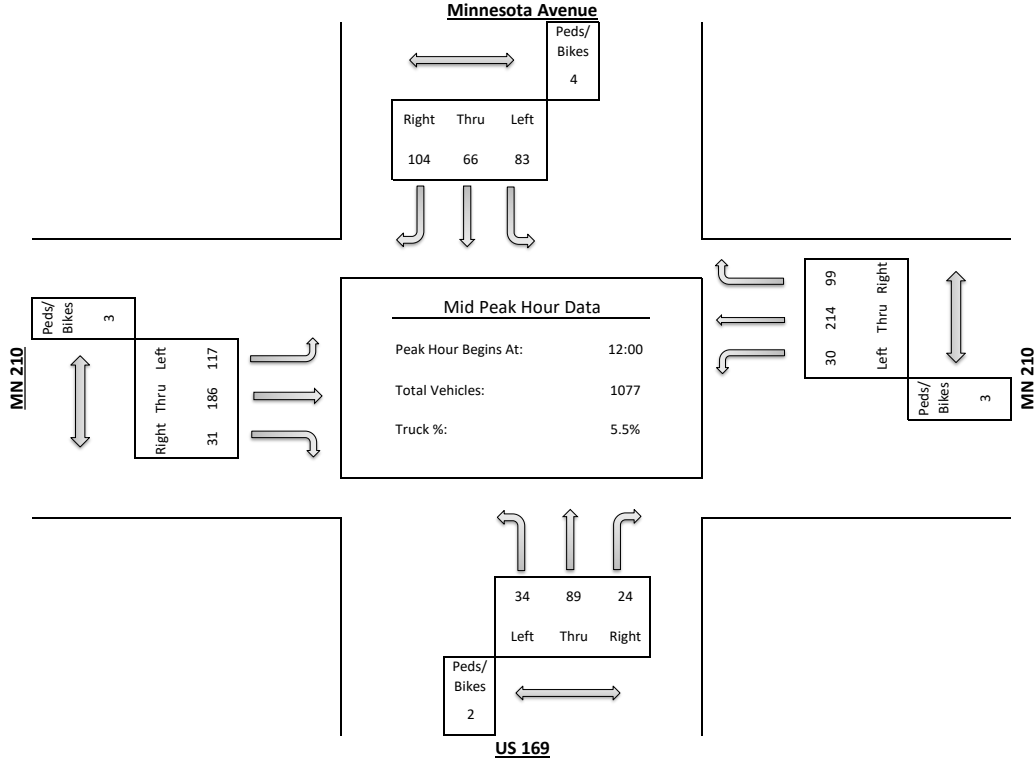

ALLIANT ENGINEERING, INC.

733 S Marquette Ave #700, Minneapolis, MN 55402

Intersection: US 169 & MN 210 (W Jct)
 Date: 5/7/2025
 Duration: 0000-2400

Site Code: 200
 Ref Pt: N/A
 Page No: 5 of 5

All Vehicles (Cars & Trucks) Printed

Start Time	Minnesota Avenue Southbound						MN 210 Westbound						US 169 Northbound						MN 210 Eastbound						Int. Veh. Total	Int. Ped/Bike Total	
	U-Turn	Left	Thru	Right	App. Total	Peds/Bikes	U-Turn	Left	Thru	Right	App. Total	Peds/Bikes	U-Turn	Left	Thru	Right	App. Total	Peds/Bikes	U-Turn	Left	Thru	Right	App. Total	Peds/Bikes			
15:15	--	34	33	32	99	2	--	6	54	23	83	4	--	10	30	8	48	1	--	22	46	5	73	2	303	9	
15:30	--	28	31	23	82	4	--	4	62	28	94	6	--	11	37	6	54	7	--	27	49	6	82	1	312	18	
15:45	--	31	14	20	65	2	--	11	62	32	105	2	--	11	18	9	38	1	--	27	64	1	92	3	300	8	
16:00	--	33	17	25	75	3	--	7	63	31	101	1	--	8	21	7	36	--	--	23	52	5	80	4	292	8	
Hour Total	--	126	95	100	321	11	--	28	241	114	383	13	--	40	106	30	176	9	--	99	211	17	327	10	1207	43	
% of App.	0.0%	39.3%	29.6%	31.2%			0.0%	7.3%	62.9%	29.8%			0.0%	22.7%	60.2%	17.0%			0.0%	30.3%	64.5%	5.2%					
% of Total	0.0%	10.4%	7.9%	8.3%	26.6%	25.6%	0.0%	2.3%	20.0%	9.4%	31.7%	30.2%	0.0%	3.3%	8.8%	2.5%	14.6%	20.9%	0.0%	8.2%	17.5%	1.4%	27.1%	23.3%			
Cars Total	--	122	93	99	314	11	--	27	229	110	366	13	--	36	97	30	163	9	--	97	189	17	303	10	1146	43	
Cars % of Movement	0.0%	96.8%	97.9%	99.0%	97.8%	25.6%	0.0%	96.4%	95.0%	96.5%	95.6%	30.2%	0.0%	90.0%	91.5%	100%	92.6%	20.9%	0.0%	98.0%	89.6%	100%	92.7%	23.3%	94.9%		
Trucks Total	--	4	2	1	7	--	--	1	12	4	17	--	--	4	9	--	13	--	--	--	2	22	--	24	--	61	--
Trucks % of Movement	0.0%	3.2%	2.1%	1.0%	2.2%	--	0.0%	3.6%	5.0%	3.5%	4.4%	--	0.0%	10.0%	8.5%	0.0%	7.4%	--	0.0%	2.0%	10.4%	0.0%	7.3%	--	5.1%		

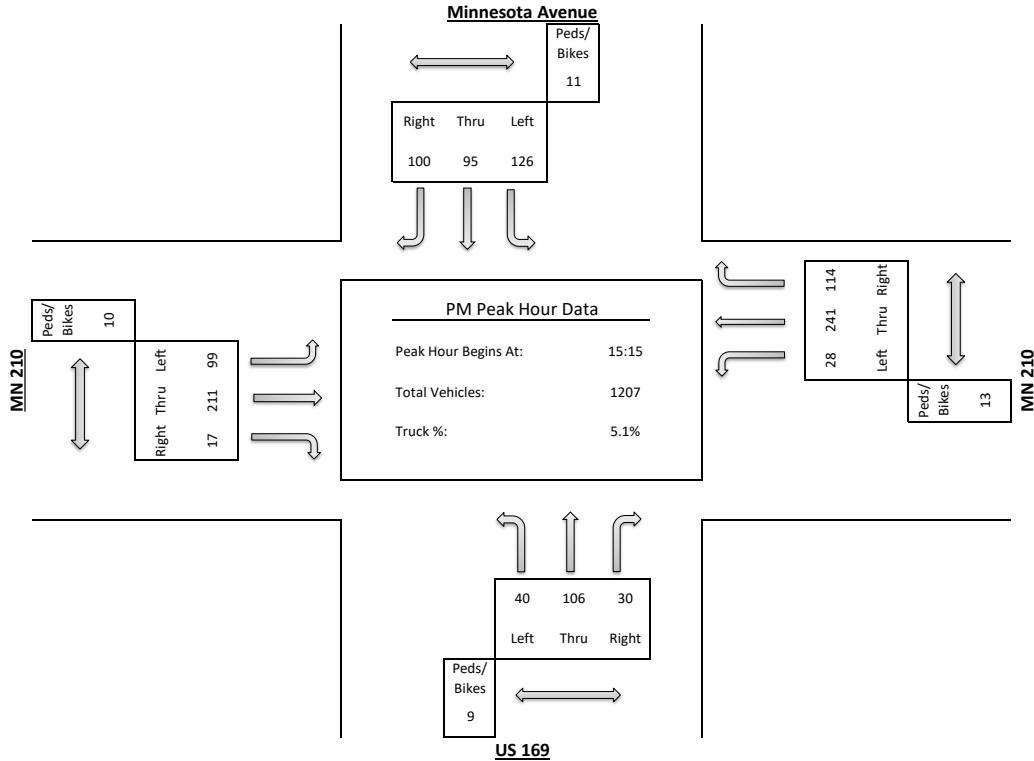

ALLIANT ENGINEERING, INC.

733 S Marquette Ave #700, Minneapolis, MN 55402

Intersection: US 169 & MN 210 (W Jct)
 Date: 5/8/2025
 Duration: 0000-2400

Site Code: 200
 Ref Pt: N/A
 Page No: 1 of 5

All Vehicles (Cars & Trucks) Printed

Start Time	Minnesota Avenue Southbound						MN 210 Westbound						US 169 Northbound						MN 210 Eastbound						Int. Veh. Total	Int. Ped/ Bike Total
	U-Turn	Left	Thru	Right	App. Total	Peds/ Bikes	U-Turn	Left	Thru	Right	App. Total	Peds/ Bikes	U-Turn	Left	Thru	Right	App. Total	Peds/ Bikes	U-Turn	Left	Thru	Right	App. Total	Peds/ Bikes		
0:00	--	1	1	2	4	--	--	--	3	--	3	--	--	--	5	--	5	--	--	--	3	--	3	--	15	--
0:15	--	--	1	1	2	--	--	--	3	--	3	--	--	--	--	--	0	1	--	--	4	--	4	--	9	1
0:30	--	--	1	2	3	--	--	--	1	--	1	--	--	1	--	1	--	--	1	--	--	--	1	--	6	--
0:45	--	1	--	2	3	--	--	--	2	2	4	--	--	1	--	--	1	--	--	1	2	--	3	--	11	--
Hour Total	--	2	3	7	12	--	--	--	9	2	11	--	--	2	5	--	7	1	--	2	9	--	11	--	41	1
1:00	--	--	--	1	1	--	--	--	3	--	3	--	--	--	--	--	0	--	--	1	1	--	2	--	6	--
1:15	--	--	--	1	1	--	--	--	--	1	1	--	--	--	--	--	0	--	--	--	--	--	0	--	2	--
1:30	--	--	--	1	1	--	--	--	1	--	1	--	--	1	--	1	--	--	1	--	--	--	1	--	4	--
1:45	--	1	--	1	2	--	--	--	3	2	5	--	--	--	1	--	1	--	--	1	--	--	1	--	9	--
Hour Total	--	1	--	4	5	--	--	--	7	3	10	--	--	2	--	2	--	--	3	1	--	4	--	21	--	
2:00	--	--	--	1	1	--	--	--	2	--	2	--	--	--	--	--	0	--	--	2	6	--	8	--	11	--
2:15	--	--	1	--	1	--	--	--	--	1	1	--	--	--	--	--	0	--	--	1	--	1	--	3	--	
2:30	--	--	--	--	0	--	--	--	--	--	0	--	--	1	--	1	--	--	--	2	--	2	--	3	--	
2:45	--	1	1	--	2	--	--	--	2	1	1	--	--	--	--	--	0	--	--	1	--	1	--	4	--	
Hour Total	--	1	2	1	4	--	--	--	2	2	4	--	--	--	1	--	1	--	--	2	10	--	12	--	21	--
3:00	--	--	--	--	0	--	--	--	1	--	1	--	--	--	--	--	0	--	--	--	--	--	0	--	1	--
3:15	--	--	--	1	1	--	--	--	1	--	1	--	--	2	--	2	--	--	--	2	--	2	--	6	--	
3:30	--	1	--	--	1	--	--	--	2	--	2	--	--	1	--	1	--	--	1	--	--	--	1	--	5	--
3:45	--	--	--	1	1	--	--	--	6	--	6	--	--	1	--	1	--	--	1	1	--	2	--	10	--	
Hour Total	--	1	--	2	3	--	--	--	10	--	10	--	--	1	3	--	4	--	--	2	3	--	5	--	22	--
4:00	--	--	--	1	1	--	--	--	1	--	1	--	--	1	--	1	--	--	--	--	--	--	0	--	3	--
4:15	--	2	--	--	2	--	--	--	3	--	3	--	--	--	--	--	0	--	--	7	--	7	--	12	--	
4:30	--	1	--	1	2	1	--	--	3	--	3	--	--	1	1	--	2	1	--	1	4	--	5	--	12	2
4:45	--	--	1	--	1	--	--	--	5	1	6	--	--	--	1	1	--	--	1	6	--	7	--	15	--	
Hour Total	--	3	1	2	6	1	--	--	12	1	13	--	--	1	2	1	4	1	--	2	17	--	19	--	42	2
5:00	--	1	--	3	4	--	--	--	10	1	11	--	--	1	2	3	--	--	4	6	--	10	--	28	--	
5:15	--	5	--	8	13	--	--	--	8	4	12	--	--	--	1	1	--	--	5	6	1	12	--	38	--	
5:30	--	4	--	4	8	--	--	--	11	7	18	1	--	1	2	5	--	--	2	13	--	15	--	46	1	
5:45	--	5	3	7	15	--	--	--	13	15	28	--	--	1	7	3	11	--	--	7	18	--	25	--	79	--
Hour Total	--	15	3	22	40	--	--	--	42	27	69	1	--	2	10	8	20	--	--	18	43	1	62	--	191	1
6:00	--	6	2	8	16	--	--	--	12	7	19	--	--	1	3	3	7	--	--	4	23	1	28	--	70	--
6:15	--	4	4	8	16	--	--	1	20	12	33	2	--	1	5	--	6	--	--	6	19	--	25	--	80	2
6:30	--	19	4	9	32	--	--	--	20	13	33	--	--	--	11	--	11	--	--	10	14	4	28	--	104	--
6:45	--	7	9	9	25	--	--	2	22	21	45	--	--	4	7	3	14	--	--	11	27	3	41	--	125	--
Hour Total	--	36	19	34	89	--	--	3	74	53	130	2	--	6	26	6	38	--	--	31	83	8	122	--	379	2
7:00	--	14	2	8	24	--	--	--	22	28	50	--	--	4	10	4	18	--	--	12	29	4	45	--	137	--
7:15	--	18	14	13	45	--	--	3	27	29	59	--	--	8	18	5	31	1	--	15	42	11	68	--	203	1
7:30	--	27	23	20	70	1	--	6	42	30	78	--	--	4	25	3	32	--	--	19	50	11	80	--	260	1
7:45	--	23	33	18	74	--	--	2	45	44	91	--	--	3	37	6	46	--	--	24	52	12	88	--	299	--
Hour Total	--	82	72	59	213	1	--	11	136	131	278	--	--	19	90	18	127	1	--	70	173	38	281	--	899	2
8:00	--	24	51	17	92	--	--	4	33	27	64	1	--	11	42	6	59	--	--	16	54	10	80	--	295	1
8:15	--	8	27	19	54	--	--	4	37	15	56	--	--	3	27	5	35	--	--	21	35	6	62	--	207	--
8:30	--	13	20	19	52	--	--	8	38	17	63	--	--	3	16	6	25	--	--	28	50	6	84	--	224	--
8:45	--	20	28	23	71	--	--	4	43	24	71	--	--	7	18	1	26	--	--	25	38	2	65	--	233	--
Hour Total	--	65	126	78	269	--	--	20	151	83	254	1	--	24	103	18	145	--	--	90	177	24	291	--	959	1
9:00	--	10	20	22	52	--	--	--	55	18	73	--	--	6	18	8	32	2	--	27	38	6	71	--	228	2
9:15	--	18	18	20	56	--	--	5	45	20	70	--	--	15	24	5	44	--	--	18	35	7	60	--	230	--
9:30	--	28	15	22	65	--	--	1	34	19	54	2	--	10	19	5	34	--	--	37	50	7	94	1	247	3
9:45	--	28	18	20	66	--	--	2	47	24	73	1	--	7	17	4	28	1	--	24	50	10	84	--	251	2
Hour Total	--	84	71	84	239	--	--	8	181	81	270	3	--	38	78	22	138	3	--	106	173	30	309	1	956	7
10:00	--	22	18	31	71	3	--	3	38	20	61	--	--	6	12	3	21	--	--	19	43	4	66	--	219	3
10:15	--	23	24	18	65	--	--	1	38	14	53	--	--	8	21	3	32	--	--	30	40	8	78	1	228	1
10:30	--	17	17	32	66	1	--	3	28	9	40	--	--	6	15	5	26	1	--	26	38	4	68	--	200	2
10:45	--	26	24	22	72	--	--	10	32	21	63	--	--	2	22	3	27	--	--	20	38	7	65	--	227	--
Hour Total	--	88	83	103	274	4	--	17	136	64	217	--	--	22	70	14	106	1	--	95	159	23	277	1	874	6
11:00	--	26	27	27	80	2	--	4	48	24	76	--	--	9	24	4	37	3	--	18	40	8	66	--	259	5
11:15	--	17	25	37	79	--	--	6	51	24	81	1	--	10	26	6	42	1	--	31	52	14	97	1	299	3
11:30	--	21	27	27	75	--	--	4	46	24	74	1	--	11	30	5	46	--	--	21	48	11	80	--	275	1
11:45	--	25	18	21	64	1	--	2	32	32	66	1	--	9	19	3	31	1	--	38	43	9	90	2	251	5
Hour Total	--	89	97	112	298	3	--	16	177	104	297	3	--	39	99	18	156	5	--	108	183	42	333	3	1084	14
12:00	--	17	11	34	62	1	--	5	43	16	64	--	--	10	18	5	33	1	--	34	41	6	81	1	240	3
12:15	--	16	28	34	78	--	--	4	51	23	78	--	--	6	24	9	39	--	--	31	39	7	77	2	272	2
12:30	--	19	9	27	55	1	--	4	54	23	81	1	--	8	25	6	39	2	--	33	61	8	102	--	277	4
12:45	--	14	26	32	72	3	--	6	43	24	73	3	--	8	21	7	36	--	--	32	45	6	83	--	264	6
Hour Total	--	66	74	127	267	5	--	19	191	86	296	4	--	32	88	27	147	3	--	130	186	27	343	3	1053	15
13:00	--	23	19	29	71	2	--	5	58	22	85	1	--	4	18	6	28	2	--	31	47	4	82	2	266	7
13:15	--	26	21	23	70	3	--	4	53	18	75	3	--	5	19	5	29	--	--	32	44	8	84	--	258	6
13:30	--	9	21	16	46	3	--	4	57	25	86	1	--	11	17	3	31	1	--	29	63	10	102	--	265	5
13:45	--	25	22	17	64	2	--	6	51	30	87	2	--	8	22	4	34	--	--	21	45	4	70	2	255	6
Hour Total	--	83	83	85	251	10	--	19	219	95	333	7</														

Hour Total	--	90	75	112	277	5	--	7	235	112	354	6	--	27	94	22	143	3	--	120	203	15	338	3	1112	17
15:00	--	27	25	34	86	--	--	4	63	21	88	1	--	5	26	8	39	--	--	26	68	7	101	--	314	1
15:15	--	28	32	31	91	1	--	5	57	34	96	1	--	10	33	6	49	1	--	25	43	8	76	--	312	3
15:30	--	26	25	25	76	1	--	8	73	18	99	1	--	18	23	3	44	2	--	23	51	2	76	--	295	4
15:45	--	34	26	26	86	2	--	6	62	24	92	2	--	21	21	5	47	1	--	24	39	3	66	1	291	6
Hour Total	--	115	108	116	339	4	--	23	255	97	375	5	--	54	103	22	179	4	--	98	201	20	319	1	1212	14
16:00	--	28	18	18	64	1	--	6	74	20	100	--	--	9	23	6	38	2	--	34	53	10	97	1	299	4
16:15	--	33	32	18	83	3	--	3	60	26	89	1	--	5	20	9	34	--	--	14	61	7	82	4	288	8
16:30	--	33	16	37	86	--	--	12	60	12	84	2	--	4	26	16	46	--	--	34	61	6	101	--	317	2
16:45	--	28	23	24	75	--	--	7	60	25	92	1	--	6	19	10	35	1	--	27	46	9	82	--	284	2
Hour Total	--	122	89	97	308	4	--	28	254	83	365	4	--	24	88	41	153	3	--	109	221	32	362	5	1188	16
17:00	--	24	17	21	62	--	--	8	51	30	89	1	--	7	27	6	40	1	--	21	46	4	71	1	262	3
17:15	--	30	28	16	74	--	--	4	41	20	65	--	--	10	16	1	27	1	--	27	44	7	78	1	244	2
17:30	--	20	17	23	60	--	--	5	36	16	57	--	--	3	23	4	30	--	--	25	42	5	72	--	219	--
17:45	--	15	17	24	56	--	--	3	41	24	68	--	--	6	14	7	27	2	--	18	42	6	66	--	217	2
Hour Total	--	89	79	84	252	--	--	20	169	90	279	1	--	26	80	18	124	4	--	91	174	22	287	2	942	7
18:00	--	16	15	8	39	--	--	3	46	22	71	--	--	3	10	3	16	--	--	17	35	5	57	--	183	--
18:15	--	12	11	17	40	--	--	7	31	14	52	--	--	5	6	3	14	2	--	14	31	3	48	--	154	2
18:30	--	12	12	15	39	--	--	5	26	9	40	2	--	5	12	3	20	1	--	14	30	2	46	--	145	3
18:45	--	10	11	19	40	--	--	5	24	16	45	--	--	2	11	--	13	--	--	15	30	7	52	--	150	--
Hour Total	--	50	49	59	158	--	--	20	127	61	208	2	--	15	39	9	63	3	--	60	126	17	203	--	632	5
19:00	--	7	12	20	39	--	--	1	15	16	32	--	--	2	12	3	17	--	--	6	22	--	28	--	116	--
19:15	--	7	15	27	49	--	--	2	17	18	37	3	--	2	5	2	9	--	--	6	21	5	32	--	127	3
19:30	--	8	16	22	46	--	--	3	19	27	49	2	--	2	10	--	12	--	--	11	20	--	31	--	138	2
19:45	--	12	7	19	38	--	--	2	18	14	34	1	--	4	6	5	15	--	--	8	20	4	32	--	119	1
Hour Total	--	34	50	88	172	--	--	8	69	75	152	6	--	10	33	10	53	--	--	31	83	9	123	--	500	6
20:00	--	9	3	24	36	--	--	3	30	11	44	1	--	4	3	3	10	--	--	12	17	1	30	2	120	3
20:15	--	6	12	21	39	--	--	2	21	10	33	--	--	1	4	--	5	1	--	8	23	4	35	1	112	2
20:30	--	1	7	20	28	--	--	3	21	16	40	2	--	2	6	3	11	--	--	5	11	1	17	--	96	2
20:45	--	9	4	15	28	--	--	2	23	8	33	--	--	4	10	3	17	1	--	7	19	1	27	--	105	1
Hour Total	--	25	26	80	131	--	--	10	95	45	150	3	--	11	23	9	43	2	--	32	70	7	109	3	433	8
21:00	--	9	9	12	30	--	--	--	12	16	28	1	--	3	3	--	6	--	--	9	17	3	29	--	93	1
21:15	--	--	3	7	10	--	--	--	13	11	24	1	--	1	1	3	5	--	--	6	14	4	24	--	63	1
21:30	--	6	2	6	14	--	--	1	6	9	16	--	--	1	2	1	4	--	--	6	11	2	19	--	53	--
21:45	--	4	4	4	12	1	--	3	8	4	15	--	--	1	1	1	3	--	--	4	18	--	22	--	52	1
Hour Total	--	19	18	29	66	1	--	4	39	40	83	2	--	6	7	5	18	--	--	25	60	9	94	--	261	3
22:00	--	4	--	5	9	--	--	--	12	2	14	--	--	1	9	--	10	--	--	1	13	1	15	--	48	--
22:15	--	5	2	4	11	--	--	1	9	9	19	--	--	--	9	--	9	2	--	5	8	--	13	--	52	2
22:30	--	3	2	4	9	--	--	3	12	7	22	--	--	2	2	--	4	--	--	4	6	1	11	--	46	--
22:45	--	3	3	2	8	--	--	1	7	1	9	--	--	--	1	1	2	--	--	1	5	1	7	1	26	1
Hour Total	--	15	7	15	37	--	--	5	40	19	64	--	--	3	21	1	25	2	--	11	32	3	46	1	172	3
23:00	--	2	3	8	13	--	--	--	8	1	9	--	--	1	1	--	2	--	--	1	14	--	15	--	39	--
23:15	--	--	--	4	4	--	--	1	9	1	11	--	--	1	--	--	1	--	--	1	8	--	9	--	25	--
23:30	--	--	1	6	7	--	--	--	6	2	8	--	--	--	1	--	1	--	--	1	8	1	10	--	26	--
23:45	--	1	3	--	4	--	--	1	8	--	9	--	--	--	--	1	1	--	--	--	4	--	4	--	18	--
Grand Total	--	1178	1142	1418	3738	38	--	240	2661	1358	4259	50	--	392	1143	288	1823	39	--	1352	2620	354	4326	27	14146	154
% of App.	0.0%	31.5%	30.6%	37.9%			0.0%	5.6%	62.5%	31.9%			0.0%	21.5%	62.7%	15.8%			0.0%	31.3%	60.6%	8.2%				
% of Total	0.0%	8.3%	8.1%	10.0%	26.4%	24.7%	0.0%	1.7%	18.8%	9.6%	30.1%	32.5%	0.0%	2.8%	8.1%	2.0%	12.9%	25.3%	0.0%	9.6%	18.5%	2.5%	30.6%	17.5%		
Cars Total	--	1145	1108	1351	3604	37	--	233	2411	1337	3981	45	--	373	1096	279	1748	38	--	1288	2383	349	4020	27	13353	147
Cars % of Movement	0.0%	97.2%	97.0%	95.3%	96.4%	25.2%	0.0%	97.1%	90.6%	98.5%	93.5%	30.6%	0.0%	95.2%	95.9%	96.9%	95.9%	25.9%	0.0%	95.3%	91.0%	98.6%	92.9%	18.4%	94.4%	
Trucks Total	--	33	34	67	134	1	--	7	250	21	278	5	--	19	47	9	75	1	--	64	237	5	306	--	793	7
Trucks % of Movement	0.0%	2.8%	3.0%	4.7%	3.6%	14.3%	0.0%	2.9%	9.4%	1.5%	6.5%	71.4%	0.0%	4.8%	4.1%	3.1%	4.1%	14.3%	0.0%	4.7%	9.0%	1.4%	7.1%	0.0%	5.6%	

ALLIANT ENGINEERING, INC.

733 S Marquette Ave #700, Minneapolis, MN 55402

Intersection: US 169 & MN 210 (W Jct)
 Date: 5/8/2025
 Duration: 0000-2400

Site Code: 200
 Ref Pt: N/A
 Page No: 3 of 5

All Vehicles (Cars & Trucks) Printed

Start Time	Minnesota Avenue Southbound						MN 210 Westbound						US 169 Northbound						MN 210 Eastbound						Int. Veh. Total	Int. Ped/Bike Total
	U-Turn	Left	Thru	Right	App. Total	Peds/Bikes	U-Turn	Left	Thru	Right	App. Total	Peds/Bikes	U-Turn	Left	Thru	Right	App. Total	Peds/Bikes	U-Turn	Left	Thru	Right	App. Total	Peds/Bikes		
7:30	--	27	23	20	70	1	--	6	42	30	78	--	--	4	25	3	32	--	--	19	50	11	80	--	260	1
7:45	--	23	33	18	74	--	--	2	45	44	91	--	--	3	37	6	46	--	--	24	52	12	88	--	299	--
8:00	--	24	51	17	92	--	--	4	33	27	64	1	--	11	42	6	59	--	--	16	54	10	80	--	295	1
8:15	--	8	27	19	54	--	--	4	37	15	56	--	--	3	27	5	35	--	--	21	35	6	62	--	207	--
Hour Total	--	82	134	74	290	1	--	16	157	116	289	1	--	21	131	20	172	--	--	80	191	39	310	--	1061	2
% of App.	0.0%	28.3%	46.2%	25.5%			0.0%	5.5%	54.3%	40.1%			0.0%	12.2%	76.2%	11.6%			0.0%	25.8%	61.6%	12.6%				
% of Total	0.0%	7.7%	12.6%	7.0%	27.3%	50.0%	0.0%	1.5%	14.8%	10.9%	27.2%	50.0%	0.0%	2.0%	12.3%	1.9%	16.2%	0.0%	0.0%	7.5%	18.0%	3.7%	29.2%	0.0%		
Cars Total	--	81	128	68	277	1	--	16	137	113	266	1	--	20	115	20	155	--	--	78	177	39	294	--	992	2
Cars % of Movement	0.0%	98.8%	95.5%	91.9%	95.5%	50.0%	0.0%	100%	87.3%	97.4%	92.0%	50.0%	0.0%	95.2%	87.8%	100%	90.1%	0.0%	0.0%	97.5%	92.7%	100%	94.8%	0.0%	93.5%	
Trucks Total	--	1	6	6	13	--	--	--	20	3	23	--	--	1	16	--	17	--	--	2	14	--	16	--	69	--
Trucks % of Movement	0.0%	1.2%	4.5%	8.1%	4.5%	--	0.0%	0.0%	12.7%	2.6%	8.0%	--	0.0%	4.8%	12.2%	0.0%	9.9%	--	0.0%	2.5%	7.3%	0.0%	5.2%	--	6.5%	

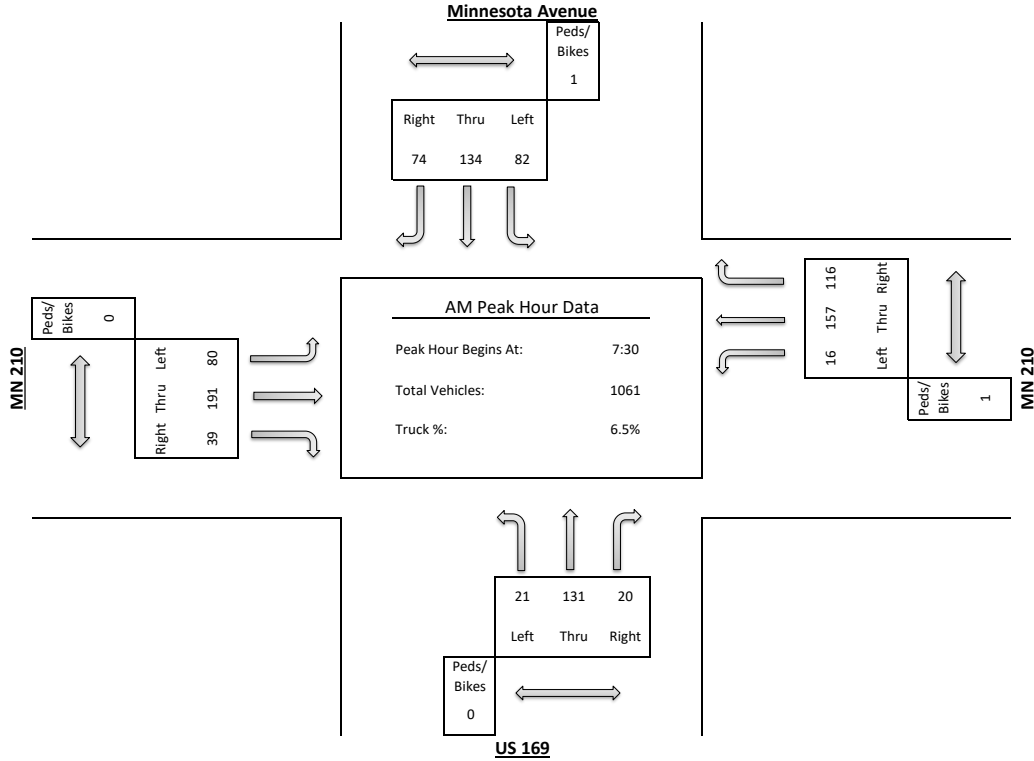

ALLIANT ENGINEERING, INC.

733 S Marquette Ave #700, Minneapolis, MN 55402

Intersection: US 169 & MN 210 (W Jct)
 Date: 5/8/2025
 Duration: 0000-2400

Site Code: 200
 Ref Pt: N/A
 Page No: 4 of 5

All Vehicles (Cars & Trucks) Printed

Start Time	Minnesota Avenue Southbound						MN 210 Westbound						US 169 Northbound						MN 210 Eastbound						Int. Veh. Total	Int. Ped/Bike Total
	U-Turn	Left	Thru	Right	App. Total	Peds/Bikes	U-Turn	Left	Thru	Right	App. Total	Peds/Bikes	U-Turn	Left	Thru	Right	App. Total	Peds/Bikes	U-Turn	Left	Thru	Right	App. Total	Peds/Bikes		
11:00	--	26	27	27	80	2	--	4	48	24	76	--	--	9	24	4	37	3	--	18	40	8	66	--	259	5
11:15	--	17	25	37	79	--	--	6	51	24	81	1	--	10	26	6	42	1	--	31	52	14	97	1	299	3
11:30	--	21	27	27	75	--	--	4	46	24	74	1	--	11	30	5	46	--	--	21	48	11	80	--	275	1
11:45	--	25	18	21	64	1	--	2	32	32	66	1	--	9	19	3	31	1	--	38	43	9	90	2	251	5
Hour Total	--	89	97	112	298	3	--	16	177	104	297	3	--	39	99	18	156	5	--	108	183	42	333	3	1084	14
% of App.	0.0%	29.9%	32.6%	37.6%			0.0%	5.4%	59.6%	35.0%			0.0%	25.0%	63.5%	11.5%			0.0%	32.4%	55.0%	12.6%				
% of Total	0.0%	8.2%	8.9%	10.3%	27.5%	21.4%	0.0%	1.5%	16.3%	9.6%	27.4%	21.4%	0.0%	3.6%	9.1%	1.7%	14.4%	35.7%	0.0%	10.0%	16.9%	3.9%	30.7%	21.4%		
Cars Total	--	85	96	106	287	3	--	14	157	101	272	3	--	37	96	18	151	5	--	103	167	41	311	3	1021	14
Cars % of Movement	0.0%	95.5%	99.0%	94.6%	96.3%	21.4%	0.0%	87.5%	88.7%	97.1%	91.6%	21.4%	0.0%	94.9%	97.0%	100%	96.8%	35.7%	0.0%	95.4%	91.3%	97.6%	93.4%	21.4%	94.2%	
Trucks Total	--	4	1	6	11	--	--	2	20	3	25	--	--	2	3	--	5	--	--	5	16	1	22	--	63	--
Trucks % of Movement	0.0%	4.5%	1.0%	5.4%	3.7%	--	0.0%	12.5%	11.3%	2.9%	8.4%	--	0.0%	5.1%	3.0%	0.0%	3.2%	--	0.0%	4.6%	8.7%	2.4%	6.6%	--	5.8%	

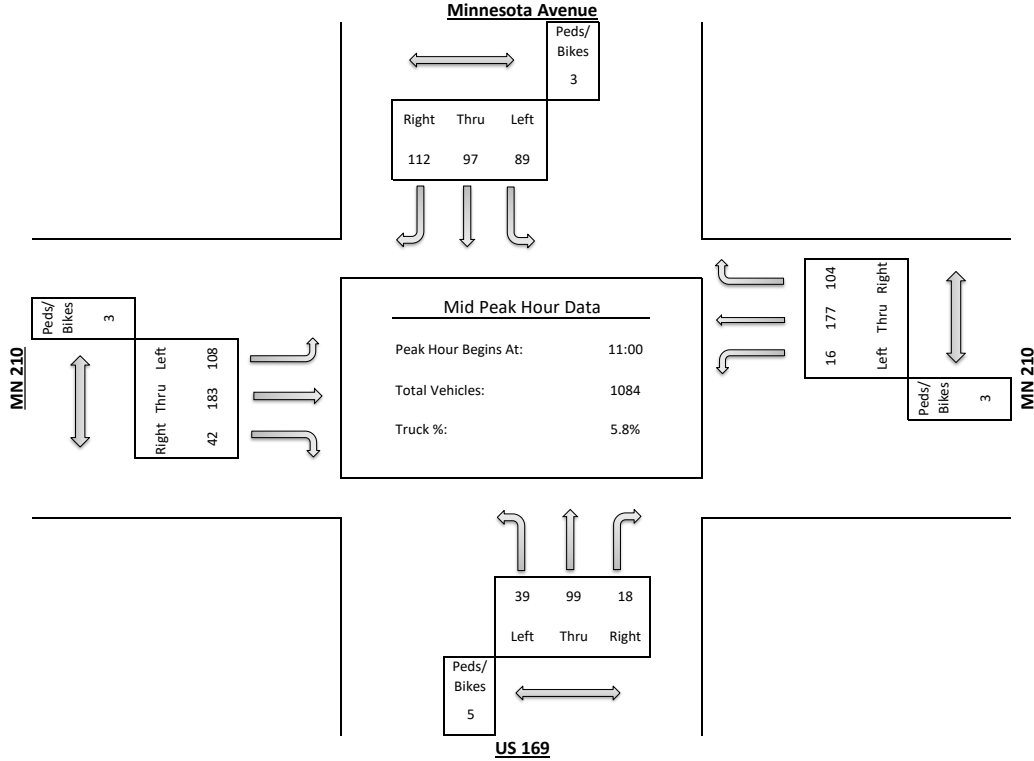

ALLIANT ENGINEERING, INC.

733 S Marquette Ave #700, Minneapolis, MN 55402

Intersection: US 169 & MN 210 (W Jct)
 Date: 5/8/2025
 Duration: 0000-2400

Site Code: 200
 Ref Pt: N/A
 Page No: 5 of 5

All Vehicles (Cars & Trucks) Printed

Start Time	Minnesota Avenue Southbound						MN 210 Westbound						US 169 Northbound						MN 210 Eastbound						Int. Veh. Total	Int. Ped/Bike Total
	U-Turn	Left	Thru	Right	App. Total	Peds/Bikes	U-Turn	Left	Thru	Right	App. Total	Peds/Bikes	U-Turn	Left	Thru	Right	App. Total	Peds/Bikes	U-Turn	Left	Thru	Right	App. Total	Peds/Bikes		
15:00	--	27	25	34	86	--	--	4	63	21	88	1	--	5	26	8	39	--	--	26	68	7	101	--	314	1
15:15	--	28	32	31	91	1	--	5	57	34	96	1	--	10	33	6	49	1	--	25	43	8	76	--	312	3
15:30	--	26	25	25	76	1	--	8	73	18	99	1	--	18	23	3	44	2	--	23	51	2	76	--	295	4
15:45	--	34	26	26	86	2	--	6	62	24	92	2	--	21	21	5	47	1	--	24	39	3	66	1	291	6
Hour Total	--	115	108	116	339	4	--	23	255	97	375	5	--	54	103	22	179	4	--	98	201	20	319	1	1212	14
% of App.	0.0%	33.9%	31.9%	34.2%			0.0%	6.1%	68.0%	25.9%			0.0%	30.2%	57.5%	12.3%			0.0%	30.7%	63.0%	6.3%				
% of Total	0.0%	9.5%	8.9%	9.6%	28.0%	28.6%	0.0%	1.9%	21.0%	8.0%	30.9%	35.7%	0.0%	4.5%	8.5%	1.8%	14.8%	28.6%	0.0%	8.1%	16.6%	1.7%	26.3%	7.1%		
Cars Total	--	111	98	113	322	3	--	23	238	97	358	5	--	49	94	22	165	4	--	91	183	20	294	1	1139	13
Cars % of Movement	0.0%	96.5%	90.7%	97.4%	95.0%	23.1%	0.0%	100%	93.3%	100%	95.5%	38.5%	0.0%	90.7%	91.3%	100%	92.2%	30.8%	0.0%	92.9%	91.0%	100%	92.2%	7.7%	94.0%	
Trucks Total	--	4	10	3	17	1	--	--	17	--	17	--	--	5	9	--	14	--	--	7	18	--	25	--	73	1
Trucks % of Movement	0.0%	3.5%	9.3%	2.6%	5.0%	100.0%	0.0%	0.0%	6.7%	0.0%	4.5%	0.0%	0.0%	9.3%	8.7%	0.0%	7.8%	0.0%	0.0%	7.1%	9.0%	0.0%	7.8%	0.0%	6.0%	

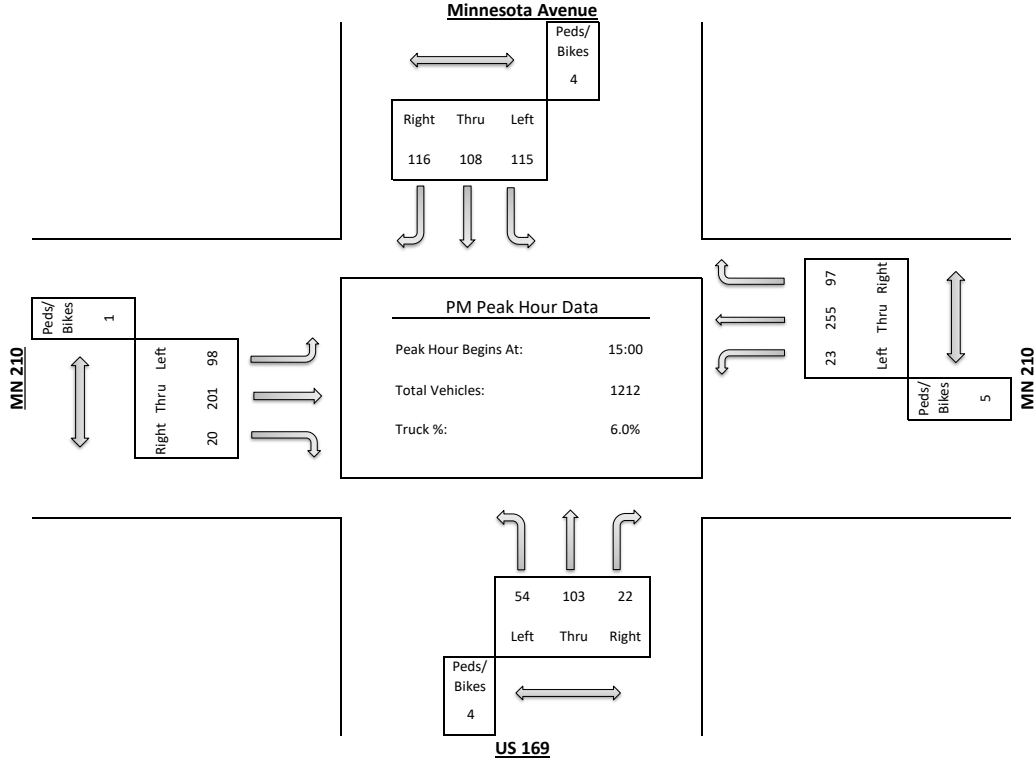

ALLIANT ENGINEERING, INC.

733 S Marquette Ave #700, Minneapolis, MN 55402

Intersection: US 169 & MN 210 (W Jct)
 Date: 5/9/2025
 Duration: 0600-1900

Site Code: 200
 Ref Pt: N/A
 Page No: 1 of 4

All Vehicles (Cars & Trucks) Printed

Start Time	Minnesota Avenue Southbound						MN 210 Westbound						US 169 Northbound						MN 210 Eastbound						Int. Veh. Total	Int. Ped/ Bike Total
	U-Turn	Left	Thru	Right	App. Total	Peds/ Bikes	U-Turn	Left	Thru	Right	App. Total	Peds/ Bikes	U-Turn	Left	Thru	Right	App. Total	Peds/ Bikes	U-Turn	Left	Thru	Right	App. Total	Peds/ Bikes		
6:00	--	--	2	1	3	--	--	6	28	1	35	--	--	4	1	8	13	--	--	--	7	10	17	--	68	--
6:15	--	1	2	2	5	--	--	7	27	2	36	--	--	6	3	5	14	--	--	3	14	8	25	--	80	--
6:30	--	--	9	6	15	--	--	6	25	6	37	--	--	10	5	9	24	--	--	--	23	12	35	--	111	--
6:45	--	2	7	4	13	--	--	15	36	1	52	--	--	14	5	18	37	--	--	2	25	17	44	1	146	1
Hour Total	--	3	20	13	36	--	--	34	116	10	160	--	--	34	14	40	88	--	--	5	69	47	121	1	405	1
7:00	--	5	6	2	13	--	--	19	26	4	49	--	--	10	13	18	41	--	--	2	11	27	40	--	143	--
7:15	--	3	18	4	25	--	--	17	38	15	70	--	--	18	14	21	53	--	--	2	20	36	58	--	206	--
7:30	--	5	26	4	35	--	--	22	50	10	82	--	--	42	27	24	93	--	--	4	39	27	70	1	280	1
7:45	--	8	27	9	44	--	--	27	56	7	90	--	--	20	38	17	75	--	--	1	51	40	92	--	301	--
Hour Total	--	21	77	19	117	--	--	85	170	36	291	--	--	90	92	80	262	--	--	9	121	130	260	1	930	1
8:00	--	6	40	1	47	1	--	22	53	13	88	--	--	28	40	22	90	2	--	3	28	42	73	1	298	4
8:15	--	7	27	5	39	1	--	18	46	8	72	--	--	25	17	31	73	--	--	7	46	15	68	1	252	2
8:30	--	5	17	5	27	--	--	23	39	10	72	2	--	16	17	14	47	--	--	4	35	11	50	2	196	4
8:45	--	11	22	6	39	--	--	24	48	8	80	--	--	21	15	36	72	--	--	4	47	20	71	1	262	1
Hour Total	--	29	106	17	152	2	--	87	186	39	312	2	--	90	89	103	282	2	--	18	156	88	262	5	1008	11
9:00	--	3	22	4	29	--	--	26	41	9	76	--	--	10	21	33	64	--	--	3	51	23	77	1	246	1
9:15	--	3	15	2	20	1	--	17	48	8	73	--	--	20	16	32	68	1	--	5	43	23	71	2	232	4
9:30	--	11	25	10	46	--	--	30	48	6	84	--	--	21	20	27	68	--	--	4	40	22	66	2	264	2
9:45	--	7	19	3	29	1	--	27	60	4	91	--	--	18	22	32	72	--	--	8	36	18	62	1	254	2
Hour Total	--	24	81	19	124	2	--	100	197	27	324	--	--	69	79	124	272	1	--	20	170	86	276	6	996	9
10:00	--	6	22	6	34	--	--	39	45	5	89	--	--	30	20	43	93	--	--	3	42	25	70	--	286	--
10:15	--	4	20	6	30	--	--	49	63	9	121	--	--	18	21	34	73	--	--	5	43	17	65	--	289	--
10:30	--	7	15	5	27	2	--	25	46	7	78	--	--	10	20	31	61	--	--	2	70	22	94	--	260	2
10:45	--	11	22	5	38	3	--	32	54	9	95	--	--	17	14	43	74	3	--	5	50	36	91	1	298	7
Hour Total	--	28	79	22	129	5	--	145	208	30	383	--	--	75	75	151	301	3	--	15	205	100	320	1	1133	9
11:00	--	7	24	5	36	--	--	19	42	12	73	--	--	19	27	35	81	--	--	2	61	19	82	2	272	2
11:15	--	9	24	6	39	2	--	35	73	9	117	--	--	18	19	46	83	1	--	4	46	20	70	2	309	5
11:30	--	6	19	5	30	--	--	28	45	2	75	2	--	24	21	39	84	--	--	4	53	24	81	3	270	5
11:45	--	5	24	7	36	2	--	39	59	7	105	--	--	25	25	37	87	1	--	2	60	24	86	1	314	4
Hour Total	--	27	91	23	141	4	--	121	219	30	370	2	--	86	92	157	335	2	--	12	220	87	319	8	1165	16
12:00	--	5	19	13	37	--	--	32	67	5	104	3	--	30	26	44	100	--	--	5	51	18	74	--	315	3
12:15	--	6	27	8	41	1	--	34	65	9	108	--	--	36	19	41	96	3	--	3	48	26	77	--	322	4
12:30	--	8	27	5	40	1	--	39	50	7	96	1	--	22	24	46	92	1	--	5	50	30	85	4	313	7
12:45	--	9	31	7	47	4	--	35	40	4	79	3	--	26	27	36	89	3	--	9	52	23	84	9	299	19
Hour Total	--	28	104	33	165	6	--	140	222	25	387	7	--	114	96	167	377	7	--	22	201	97	320	13	1249	33
13:00	--	12	30	7	49	2	--	44	39	10	93	1	--	22	29	37	88	--	--	9	58	18	85	--	315	3
13:15	--	10	34	5	49	2	--	39	51	6	96	1	--	23	30	44	97	1	--	7	56	23	86	5	328	9
13:30	--	7	20	12	39	3	--	34	64	4	102	--	--	13	37	37	87	--	--	2	58	27	87	--	315	3
13:45	--	4	18	3	25	1	--	35	67	9	111	2	--	16	27	31	74	4	--	8	49	33	90	2	300	9
Hour Total	--	33	102	27	162	8	--	152	221	29	402	4	--	74	123	149	346	5	--	26	222	101	348	7	1258	24
14:00	--	5	28	5	38	--	--	38	55	4	97	2	--	25	18	33	76	2	--	5	69	21	95	9	306	13
14:15	--	3	32	7	42	--	--	26	55	8	89	1	--	16	26	36	78	4	--	5	59	16	80	4	289	9
14:30	--	10	29	11	50	--	--	31	62	7	100	--	--	23	15	46	84	4	--	5	48	32	85	2	319	6
14:45	--	5	17	4	26	--	--	33	53	6	92	3	--	28	19	28	75	2	--	2	51	31	84	2	277	7
Hour Total	--	23	106	27	156	--	--	128	225	25	378	6	--	92	78	143	313	12	--	17	227	100	344	17	1191	35
15:00	--	5	18	5	28	4	--	32	68	7	107	--	--	35	25	32	92	--	--	6	50	28	84	7	311	11
15:15	--	14	42	3	59	2	--	32	46	6	84	1	--	32	46	41	119	1	--	5	55	33	93	3	355	7
15:30	--	15	38	6	59	--	--	33	55	7	95	--	--	28	26	34	88	1	--	6	76	33	115	4	357	5
15:45	--	7	33	4	44	3	--	30	71	7	108	1	--	31	18	34	83	1	--	7	68	27	102	2	337	7
Hour Total	--	41	131	18	190	9	--	127	240	27	394	2	--	126	115	141	382	3	--	24	249	121	394	16	1360	30
16:00	--	13	25	6	44	3	--	23	64	9	96	1	--	27	28	43	98	1	--	3	60	27	90	1	328	6
16:15	--	4	30	6	40	2	--	25	62	6	93	--	--	36	29	43	108	1	--	7	44	27	78	--	319	3
16:30	--	6	33	8	47	--	--	29	60	3	92	--	--	29	17	38	84	1	--	5	73	46	124	1	347	2
16:45	--	12	19	9	40	--	--	27	56	11	94	1	--	21	28	41	90	2	--	5	55	31	91	1	315	4
Hour Total	--	35	107	29	171	5	--	104	242	29	375	2	--	113	102	165	380	5	--	20	232	131	383	3	1309	15
17:00	--	6	28	8	42	--	--	32	56	5	93	--	--	22	28	25	75	--	--	--	67	27	94	1	304	1
17:15	--	4	13	4	21	1	--	32	38	10	80	1	--	21	22	35	78	--	--	7	49	26	82	1	261	3
17:30	--	2	19	2	23	--	--	30	55	8	93	--	--	16	21	43	80	1	--	4	46	32	82	--	278	1
17:45	--	6	13	3	22	2	--	22	46	2	70	2	--	24	18	29	71	--	--	5	56	28	89	1	252	5
Hour Total	--	18	73	17	108	3	--	116	195	25	336	3	--	83	89	132	304	1	--	16	218	113	347	3	1095	10
18:00	--	7	12	2	21	2	--	12	53	1	66	--	--	28	16	29	73	2	--	7	39	11	57	7	217	11
18:15	--	5	14	7	26	--	--	19	48	3	70	--	--	17	16	36										

ALLIANT ENGINEERING, INC.

733 S Marquette Ave #700, Minneapolis, MN 55402

Intersection: US 169 & MN 210 (W Jct)
 Date: 5/9/2025
 Duration: 0600-1900

Site Code: 200
 Ref Pt: N/A
 Page No: 2 of 4

All Vehicles (Cars & Trucks) Printed

Start Time	Minnesota Avenue Southbound						MN 210 Westbound						US 169 Northbound						MN 210 Eastbound						Int. Veh. Total	Int. Ped/Bike Total
	U-Turn	Left	Thru	Right	App. Total	Peds/Bikes	U-Turn	Left	Thru	Right	App. Total	Peds/Bikes	U-Turn	Left	Thru	Right	App. Total	Peds/Bikes	U-Turn	Left	Thru	Right	App. Total	Peds/Bikes		
7:30	--	5	26	4	35	--	--	22	50	10	82	--	--	42	27	24	93	--	--	4	39	27	70	1	280	1
7:45	--	8	27	9	44	--	--	27	56	7	90	--	--	20	38	17	75	--	--	1	51	40	92	--	301	--
8:00	--	6	40	1	47	1	--	22	53	13	88	--	--	28	40	22	90	2	--	3	28	42	73	1	298	4
8:15	--	7	27	5	39	1	--	18	46	8	72	--	--	25	17	31	73	--	--	7	46	15	68	1	252	2
Hour Total	--	26	120	19	165	2	--	89	205	38	332	--	--	115	122	94	331	2	--	15	164	124	303	3	1131	7
% of App.	0.0%	15.8%	72.7%	11.5%			0.0%	26.8%	61.7%	11.4%			0.0%	34.7%	36.9%	28.4%			0.0%	5.0%	54.1%	40.9%				
% of Total	0.0%	2.3%	10.6%	1.7%	14.6%	28.6%	0.0%	7.9%	18.1%	3.4%	29.4%	0.0%	0.0%	10.2%	10.8%	8.3%	29.3%	28.6%	0.0%	1.3%	14.5%	11.0%	26.8%	42.9%		
Cars Total	--	24	107	19	150	2	--	87	186	38	311	--	--	111	115	93	319	2	--	15	151	120	286	2	1066	6
Cars % of Movement	0.0%	92.3%	89.2%	100%	90.9%	33.3%	0.0%	97.8%	90.7%	100%	93.7%	0.0%	0.0%	96.5%	94.3%	98.9%	96.4%	33.3%	0.0%	100%	92.1%	96.8%	94.4%	33.3%	94.3%	
Trucks Total	--	2	13	--	15	--	--	2	19	--	21	--	--	4	7	1	12	--	--	--	13	4	17	1	65	1
Trucks % of Movement	0.0%	7.7%	10.8%	0.0%	9.1%	0.0%	0.0%	2.2%	9.3%	0.0%	6.3%	0.0%	0.0%	3.5%	5.7%	1.1%	3.6%	0.0%	0.0%	0.0%	7.9%	3.2%	5.6%	100.0%	5.7%	

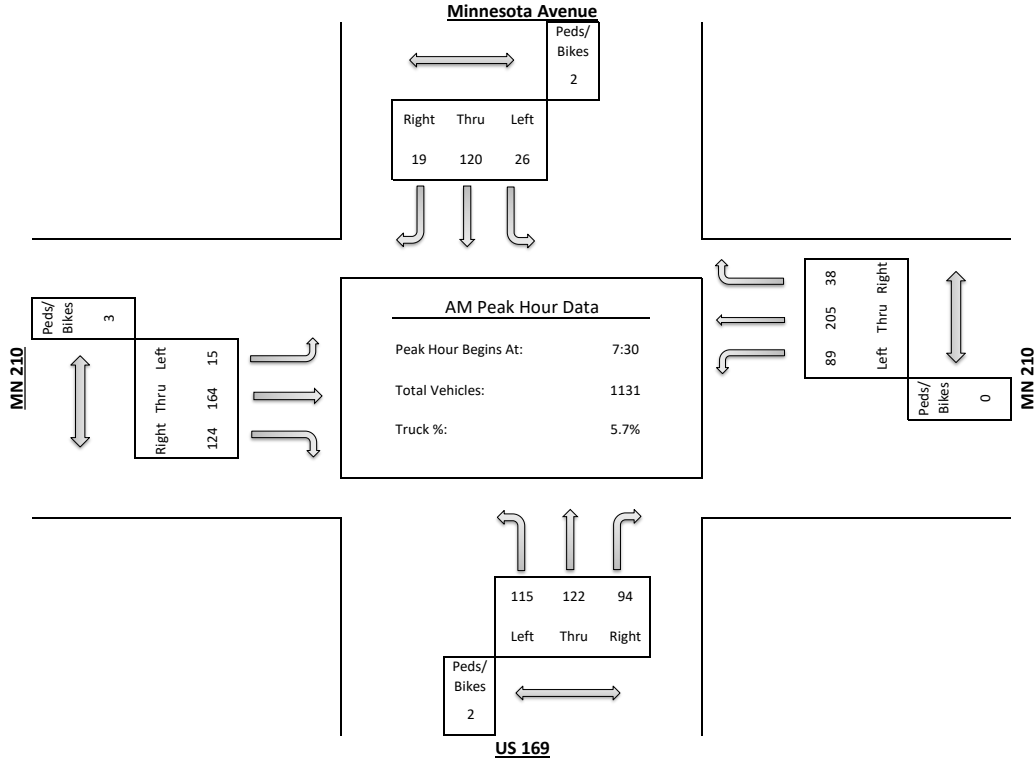

ALLIANT ENGINEERING, INC.

733 S Marquette Ave #700, Minneapolis, MN 55402

Intersection: US 169 & MN 210 (W Jct)
 Date: 5/9/2025
 Duration: 0600-1900

Site Code: 200
 Ref Pt: N/A
 Page No: 3 of 4

All Vehicles (Cars & Trucks) Printed

Start Time	Minnesota Avenue Southbound						MN 210 Westbound						US 169 Northbound						MN 210 Eastbound						Int. Veh. Total	Int. Ped/Bike Total
	U-Turn	Left	Thru	Right	App. Total	Peds/Bikes	U-Turn	Left	Thru	Right	App. Total	Peds/Bikes	U-Turn	Left	Thru	Right	App. Total	Peds/Bikes	U-Turn	Left	Thru	Right	App. Total	Peds/Bikes		
11:45	--	5	24	7	36	2	--	39	59	7	105	--	--	25	25	37	87	1	--	2	60	24	86	1	314	4
12:00	--	5	19	13	37	--	--	32	67	5	104	3	--	30	26	44	100	--	--	5	51	18	74	--	315	3
12:15	--	6	27	8	41	1	--	34	65	9	108	--	--	36	19	41	96	3	--	3	48	26	77	--	322	4
12:30	--	8	27	5	40	1	--	39	50	7	96	1	--	22	24	46	92	1	--	5	50	30	85	4	313	7
Hour Total	--	24	97	33	154	4	--	144	241	28	413	4	--	113	94	168	375	5	--	15	209	98	322	5	1264	18
% of App.	0.0%	15.6%	63.0%	21.4%			0.0%	34.9%	58.4%	6.8%			0.0%	30.1%	25.1%	44.8%			0.0%	4.7%	64.9%	30.4%				
% of Total	0.0%	1.9%	7.7%	2.6%	12.2%	22.2%	0.0%	11.4%	19.1%	2.2%	32.7%	22.2%	0.0%	8.9%	7.4%	13.3%	29.7%	27.8%	0.0%	1.2%	16.5%	7.8%	25.5%	27.8%		
Cars Total	--	23	94	33	150	4	--	137	224	28	389	4	--	111	94	166	371	5	--	13	200	97	310	5	1220	18
Cars % of Movement	0.0%	95.8%	96.9%	100%	97.4%	22.2%	0.0%	95.1%	92.9%	100%	94.2%	22.2%	0.0%	98.2%	100%	98.8%	98.9%	27.8%	0.0%	86.7%	95.7%	99.0%	96.3%	27.8%	96.5%	
Trucks Total	--	1	3	--	4	--	--	7	17	--	24	--	--	2	--	2	4	--	--	2	9	1	12	--	44	--
Trucks % of Movement	0.0%	4.2%	3.1%	0.0%	2.6%	--	0.0%	4.9%	7.1%	0.0%	5.8%	--	0.0%	1.8%	0.0%	1.2%	1.1%	--	0.0%	13.3%	4.3%	1.0%	3.7%	--	3.5%	

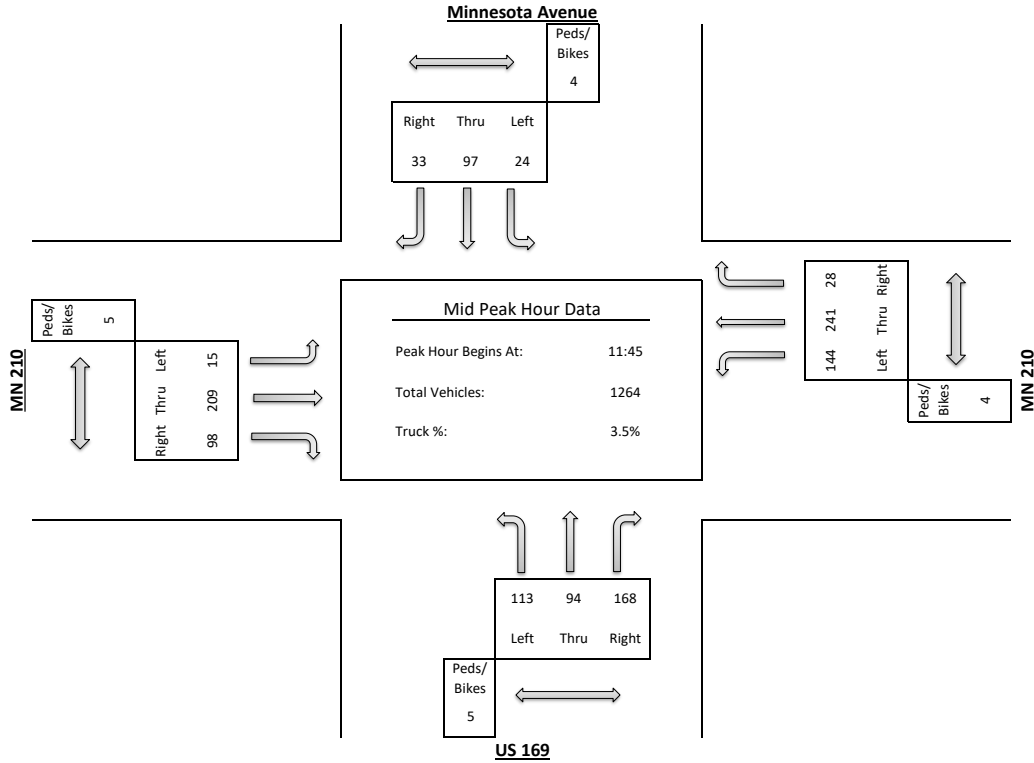

ALLIANT ENGINEERING, INC.

733 S Marquette Ave #700, Minneapolis, MN 55402

Intersection: US 169 & MN 210 (W Jct)
 Date: 5/9/2025
 Duration: 0600-1900

Site Code: 200
 Ref Pt: N/A
 Page No: 4 of 4

All Vehicles (Cars & Trucks) Printed

Start Time	Minnesota Avenue Southbound						MN 210 Westbound						US 169 Northbound						MN 210 Eastbound						Int. Veh. Total	Int. Ped/Bike Total
	U-Turn	Left	Thru	Right	App. Total	Peds/Bikes	U-Turn	Left	Thru	Right	App. Total	Peds/Bikes	U-Turn	Left	Thru	Right	App. Total	Peds/Bikes	U-Turn	Left	Thru	Right	App. Total	Peds/Bikes		
15:15	--	14	42	3	59	2	--	32	46	6	84	1	--	32	46	41	119	1	--	5	55	33	93	3	355	7
15:30	--	15	38	6	59	--	--	33	55	7	95	--	--	28	26	34	88	1	--	6	76	33	115	4	357	5
15:45	--	7	33	4	44	3	--	30	71	7	108	1	--	31	18	34	83	1	--	7	68	27	102	2	337	7
16:00	--	13	25	6	44	3	--	23	64	9	96	1	--	27	28	43	98	1	--	3	60	27	90	1	328	6
Hour Total	--	49	138	19	206	8	--	118	236	29	383	3	--	118	118	152	388	4	--	21	259	120	400	10	1377	25
% of App.	0.0%	23.8%	67.0%	9.2%			0.0%	30.8%	61.6%	7.6%			0.0%	30.4%	30.4%	39.2%			0.0%	5.3%	64.8%	30.0%				
% of Total	0.0%	3.6%	10.0%	1.4%	15.0%	32.0%	0.0%	8.6%	17.1%	2.1%	27.8%	12.0%	0.0%	8.6%	8.6%	11.0%	28.2%	16.0%	0.0%	1.5%	18.8%	8.7%	29.0%	40.0%		
Cars Total	--	43	131	18	192	8	--	116	222	28	366	3	--	114	113	152	379	4	--	20	245	120	385	10	1322	25
Cars % of Movement	0.0%	87.8%	94.9%	94.7%	93.2%	32.0%	0.0%	98.3%	94.1%	96.6%	95.6%	12.0%	0.0%	96.6%	95.8%	100%	97.7%	16.0%	0.0%	95.2%	94.6%	100%	96.3%	40.0%	96.0%	
Trucks Total	--	6	7	1	14	--	--	2	14	1	17	--	--	4	5	--	9	--	--	1	14	--	15	--	55	--
Trucks % of Movement	0.0%	12.2%	5.1%	5.3%	6.8%	--	0.0%	1.7%	5.9%	3.4%	4.4%	--	0.0%	3.4%	4.2%	0.0%	2.3%	--	0.0%	4.8%	5.4%	0.0%	3.8%	--	4.0%	

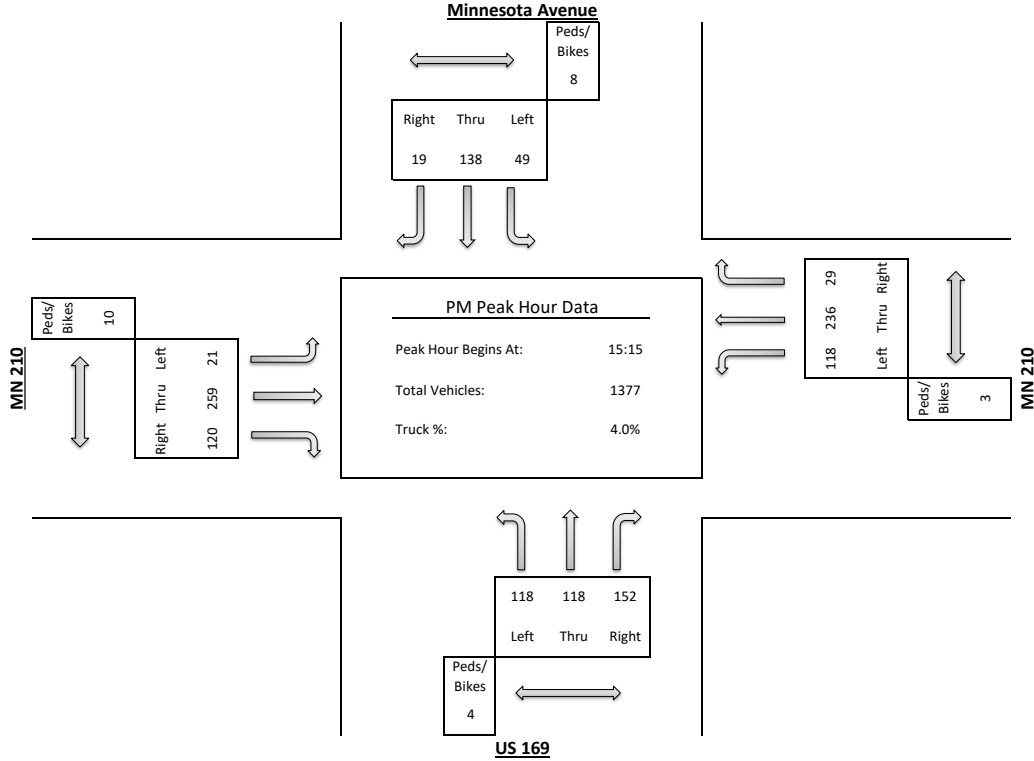

ALLIANT ENGINEERING, INC.

733 S Marquette Ave #700, Minneapolis, MN 55402

Intersection: US 169 & MN 210 (W Jct)
 Date: 5/11/2025
 Duration: 0600-1900

Site Code: 200
 Ref Pt: N/A
 Page No: 1 of 4

All Vehicles (Cars & Trucks) Printed

Start Time	Minnesota Avenue Southbound						MN 210 Westbound						US 169 Northbound						MN 210 Eastbound						Int. Veh. Total	Int. Ped/ Bike Total
	U-Turn	Left	Thru	Right	App. Total	Peds/ Bikes	U-Turn	Left	Thru	Right	App. Total	Peds/ Bikes	U-Turn	Left	Thru	Right	App. Total	Peds/ Bikes	U-Turn	Left	Thru	Right	App. Total	Peds/ Bikes		
6:00	--	--	1	1	2	--	--	2	2	--	4	--	--	1	--	3	4	--	--	1	2	3	6	--	16	--
6:15	--	--	1	--	1	--	--	4	8	--	12	--	--	4	--	1	5	--	--	--	6	3	9	1	27	1
6:30	--	--	8	1	9	1	--	7	4	--	11	--	--	2	1	2	5	--	--	--	5	4	9	--	34	1
6:45	--	--	4	1	5	--	--	5	5	1	11	--	--	6	3	6	15	--	--	--	5	6	11	1	42	1
Hour Total	--	--	14	3	17	1	--	18	19	1	38	--	--	13	4	12	29	--	--	1	18	16	35	2	119	3
7:00	--	1	4	1	6	--	--	7	9	--	16	--	--	8	6	2	16	--	--	--	9	4	13	--	51	--
7:15	--	--	4	--	4	--	--	11	7	1	19	1	--	5	5	8	18	--	--	1	9	5	15	1	56	2
7:30	--	4	7	3	14	--	--	19	15	2	36	--	--	7	2	7	16	--	--	1	23	16	40	--	106	--
7:45	--	3	8	3	14	--	--	23	23	3	49	--	--	13	6	8	27	--	--	2	19	24	45	1	135	1
Hour Total	--	8	23	7	38	--	--	60	54	6	120	1	--	33	19	25	77	--	--	4	60	49	113	2	348	3
8:00	--	2	7	1	10	--	--	18	30	2	50	1	--	14	4	10	28	--	--	1	23	23	47	--	135	1
8:15	--	1	7	--	8	--	--	19	24	2	45	1	--	11	2	14	27	--	--	1	11	12	24	1	104	2
8:30	--	6	13	5	24	--	--	24	22	--	46	--	--	13	5	11	29	--	--	1	15	21	37	--	136	--
8:45	--	4	13	2	19	--	--	27	35	2	64	--	--	20	13	12	45	4	--	3	29	34	66	4	194	8
Hour Total	--	13	40	8	61	--	--	88	111	6	205	2	--	58	24	47	129	4	--	6	78	90	174	5	569	11
9:00	--	--	10	4	14	--	--	24	25	3	52	--	--	5	9	19	33	--	--	1	31	19	51	1	150	1
9:15	--	3	22	1	26	--	--	43	24	4	71	--	--	14	11	13	38	--	--	2	31	20	53	1	188	1
9:30	--	4	15	1	20	1	--	57	29	2	88	--	--	21	9	22	52	--	--	1	40	18	59	--	219	1
9:45	--	1	19	2	22	--	--	58	37	6	101	--	--	23	25	17	65	--	--	8	37	34	79	--	267	--
Hour Total	--	8	66	8	82	1	--	182	115	15	312	--	--	63	54	71	188	--	--	12	139	91	242	2	824	3
10:00	--	3	26	3	32	--	--	53	42	14	109	6	--	29	16	11	56	--	--	4	57	34	95	2	292	8
10:15	--	9	29	4	42	--	--	49	51	8	108	2	--	39	11	31	81	--	--	1	39	43	83	2	314	4
10:30	--	4	23	2	29	--	--	46	47	4	97	--	--	26	13	19	58	--	--	1	48	29	78	--	262	--
10:45	--	5	23	5	33	2	--	33	41	4	78	--	--	36	17	25	78	--	--	3	41	26	70	3	259	5
Hour Total	--	21	101	14	136	2	--	181	181	30	392	8	--	130	57	86	273	--	--	9	185	132	326	7	1127	17
11:00	--	13	18	6	37	1	--	61	44	8	113	2	--	22	14	33	69	--	--	3	75	26	104	--	323	3
11:15	--	7	23	3	33	--	--	34	55	7	96	2	--	14	14	24	52	2	--	7	66	21	94	1	275	5
11:30	--	3	12	2	17	--	--	57	54	7	118	--	--	28	9	27	64	--	--	4	47	45	96	--	295	--
11:45	--	7	26	3	36	--	--	37	61	5	103	--	--	37	25	37	99	--	--	2	50	31	83	--	321	--
Hour Total	--	30	79	14	123	1	--	189	214	27	430	4	--	101	62	121	284	2	--	16	238	123	377	1	1214	8
12:00	--	4	13	3	20	--	--	46	63	3	112	--	--	23	25	22	70	--	--	5	56	34	95	1	297	1
12:15	--	7	16	2	25	1	--	53	54	7	114	--	--	21	13	28	62	--	--	4	66	34	104	--	305	1
12:30	--	10	21	9	40	--	--	46	62	7	115	2	--	22	14	19	55	--	--	3	68	32	103	--	313	2
12:45	--	4	15	3	22	--	--	64	53	8	125	--	--	21	26	28	75	--	--	12	68	30	110	--	332	--
Hour Total	--	25	65	17	107	1	--	209	232	25	466	2	--	87	78	97	262	--	--	24	258	130	412	1	1247	4
13:00	--	6	18	3	27	1	--	38	49	4	91	--	--	23	18	39	80	4	--	4	81	31	116	1	314	6
13:15	--	3	10	4	17	1	--	37	54	8	99	--	--	32	12	26	70	--	--	5	56	33	94	--	280	1
13:30	--	4	11	1	16	--	--	48	49	2	99	--	--	22	11	30	63	--	--	1	28	23	52	--	230	--
13:45	--	6	17	5	28	--	--	42	63	4	109	--	--	17	14	23	54	3	--	2	52	22	76	--	267	3
Hour Total	--	19	56	13	88	2	--	165	215	18	398	--	--	94	55	118	267	7	--	12	217	109	338	1	1091	10
14:00	--	5	20	2	27	--	--	64	50	4	118	--	--	9	12	21	42	--	--	1	45	18	64	--	251	--
14:15	--	1	13	5	19	--	--	53	42	6	101	--	--	11	17	17	45	--	--	2	37	24	63	--	228	--
14:30	--	6	15	3	24	--	--	44	46	3	93	--	--	17	10	21	48	--	--	5	46	26	77	--	242	--
14:45	--	3	14	5	22	2	--	27	47	5	79	2	--	20	9	24	53	--	--	1	43	26	70	4	224	8
Hour Total	--	15	62	15	92	2	--	188	185	18	391	2	--	57	48	83	188	--	--	9	171	94	274	4	945	8
15:00	--	6	11	1	18	--	--	36	37	3	76	1	--	22	16	34	72	--	--	3	43	28	74	--	240	1
15:15	--	7	15	3	25	--	--	37	40	5	82	--	--	27	15	23	65	1	--	3	31	13	47	1	219	2
15:30	--	3	17	3	23	--	--	30	53	2	85	1	--	21	9	18	48	--	--	1	47	10	58	1	214	2
15:45	--	2	17	3	22	--	--	27	45	4	76	--	--	14	9	27	50	--	--	1	44	20	65	1	213	1
Hour Total	--	18	60	10	88	--	--	130	175	14	319	2	--	84	49	102	235	1	--	8	165	71	244	3	886	6
16:00	--	4	17	1	22	1	--	28	39	7	74	1	--	18	17	23	58	--	--	8	35	21	64	2	218	4
16:15	--	2	9	3	14	--	--	26	38	3	67	--	--	15	21	26	62	--	--	2	31	22	55	--	198	--
16:30	--	3	7	--	10	--	--	30	35	6	71	--	--	15	8	28	51	--	--	2	32	22	56	--	188	--
16:45	--	5	10	--	15	2	--	21	39	1	61	--	--	8	5	24	37	1	--	--	42	14	56	2	169	5
Hour Total	--	14	43	4	61	3	--	105	151	17	273	1	--	56	51	101	208	1	--	12	140	79	231	4	773	9
17:00	--	3	14	1	18	--	--	16	36	8	60	1	--	17	10	23	50	--	--	5	56	26	87	2	215	3
17:15	--	2	4	1	7	1	--	30	36	5	71	--	--	12	12	24	48	1	--	1	46	15	62	1	188	3
17:30	--	6	10	2	18	1	--	29	42	1	72	--	--	13	10	17	40	--	--	3	28	17	48	--	178	1
17:45	--	2	7	3	12	--	--	37	34	3	74	--	--	19	12	16	47	--	--	8	31	12	51	--	184	--
Hour Total	--	13	35	7	55	2	--	112	148	17	277	1	--	61	44	80	185	1	--	17	161	70	248	3	765	7
18:00	--	--	13	1	14	--	--	21	30	4	55	--	--	13	9	16	38	2	--	2	29	10	41	--	148	2
18:15	--	5	13	2	20	--	--	28	32	5	65	--	--	11	9	17	37	--	--	--	18	16	34	--	156	--
18:30	--	2	5	5	12	--	--	24	32	7	63	--	--	7	8	15	30	--	--	2	26	15	43	--	148	--
18:45	--	2	13	3	18	--	--	22	33	2	57	--	--	8	9	11	28	--	--	2	38	10	50	--	153	--
Hour Total	--	9	44	11	64	--	--	95	127	18	240	--	--	39	35	59										

ALLIANT ENGINEERING, INC.

733 S Marquette Ave #700, Minneapolis, MN 55402

Intersection: US 169 & MN 210 (W Jct)
 Date: 5/11/2025
 Duration: 0600-1900

Site Code: 200
 Ref Pt: N/A
 Page No: 2 of 4

All Vehicles (Cars & Trucks) Printed

Start Time	Minnesota Avenue Southbound						MN 210 Westbound						US 169 Northbound						MN 210 Eastbound						Int. Veh. Total	Int. Ped/Bike Total	
	U-Turn	Left	Thru	Right	App. Total	Peds/Bikes	U-Turn	Left	Thru	Right	App. Total	Peds/Bikes	U-Turn	Left	Thru	Right	App. Total	Peds/Bikes	U-Turn	Left	Thru	Right	App. Total	Peds/Bikes			
8:30	--	6	13	5	24	--	--	24	22	--	46	--	--	13	5	11	29	--	--	1	15	21	37	--	136	--	
8:45	--	4	13	2	19	--	--	27	35	2	64	--	--	20	13	12	45	4	--	3	29	34	66	4	194	8	
9:00	--	--	10	4	14	--	--	24	25	3	52	--	--	5	9	19	33	--	--	1	31	19	51	1	150	1	
9:15	--	3	22	1	26	--	--	43	24	4	71	--	--	14	11	13	38	--	--	2	31	20	53	1	188	1	
Hour Total	--	13	58	12	83	--	--	118	106	9	233	--	--	52	38	55	145	4	--	7	106	94	207	6	668	10	
% of App.	0.0%	15.7%	69.9%	14.5%			0.0%	50.6%	45.5%	3.9%			0.0%	35.9%	26.2%	37.9%			0.0%	3.4%	51.2%	45.4%					
% of Total	0.0%	1.9%	8.7%	1.8%	12.4%	0.0%	0.0%	17.7%	15.9%	1.3%	34.9%	0.0%	0.0%	7.8%	5.7%	8.2%	21.7%	40.0%	0.0%	1.0%	15.9%	14.1%	31.0%	60.0%			
Cars Total	--	13	58	12	83	--	--	118	104	9	231	--	--	52	38	55	145	4	--	4	104	94	202	6	661	10	
Cars % of Movement	0.0%	100%	100%	100%	100%	0.0%	0.0%	100%	98.1%	100%	99.1%	0.0%	0.0%	100%	100%	100%	100%	40.0%	0.0%	57.1%	98.1%	100%	97.6%	60.0%	99.0%		
Trucks Total	--	--	--	--	0	--	--	--	2	--	2	--	--	--	--	--	0	--	--	--	3	2	--	5	--	7	--
Trucks % of Movement	0.0%	0.0%	0.0%	0.0%	0.0%	--	0.0%	0.0%	1.9%	0.0%	0.9%	--	0.0%	0.0%	0.0%	0.0%	--	--	0.0%	42.9%	1.9%	0.0%	2.4%	--	1.0%		

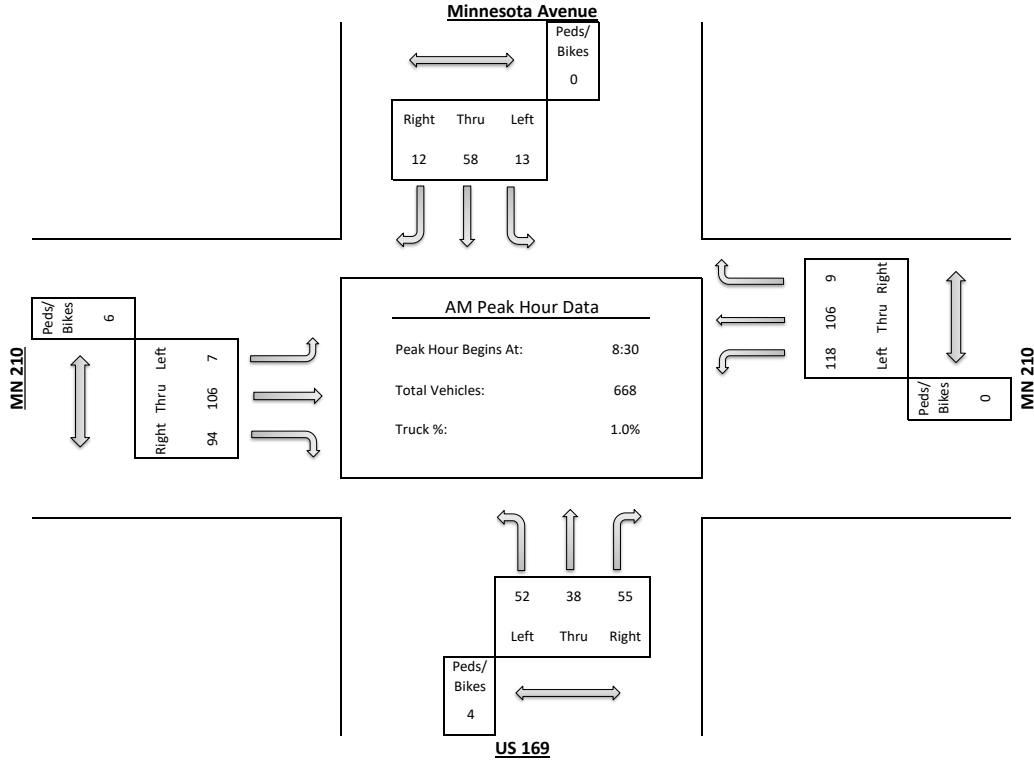

ALLIANT ENGINEERING, INC.

733 S Marquette Ave #700, Minneapolis, MN 55402

Intersection: US 169 & MN 210 (W Jct)
 Date: 5/11/2025
 Duration: 0600-1900

Site Code: 200
 Ref Pt: N/A
 Page No: 3 of 4

All Vehicles (Cars & Trucks) Printed

Start Time	Minnesota Avenue Southbound						MN 210 Westbound						US 169 Northbound						MN 210 Eastbound						Int. Veh. Total	Int. Ped/Bike Total
	U-Turn	Left	Thru	Right	App. Total	Peds/Bikes	U-Turn	Left	Thru	Right	App. Total	Peds/Bikes	U-Turn	Left	Thru	Right	App. Total	Peds/Bikes	U-Turn	Left	Thru	Right	App. Total	Peds/Bikes		
12:15	--	7	16	2	25	1	--	53	54	7	114	--	--	21	13	28	62	--	--	4	66	34	104	--	305	1
12:30	--	10	21	9	40	--	--	46	62	7	115	2	--	22	14	19	55	--	--	3	68	32	103	--	313	2
12:45	--	4	15	3	22	--	--	64	53	8	125	--	--	21	26	28	75	--	--	12	68	30	110	--	332	--
13:00	--	6	18	3	27	1	--	38	49	4	91	--	--	23	18	39	80	4	--	4	81	31	116	1	314	6
Hour Total	--	27	70	17	114	2	--	201	218	26	445	2	--	87	71	114	272	4	--	23	283	127	433	1	1264	9
% of App.	0.0%	23.7%	61.4%	14.9%			0.0%	45.2%	49.0%	5.8%			0.0%	32.0%	26.1%	41.9%			0.0%	5.3%	65.4%	29.3%				
% of Total	0.0%	2.1%	5.5%	1.3%	9.0%	22.2%	0.0%	15.9%	17.2%	2.1%	35.2%	22.2%	0.0%	6.9%	5.6%	9.0%	21.5%	44.4%	0.0%	1.8%	22.4%	10.0%	34.3%	11.1%		
Cars Total	--	26	70	16	112	2	--	201	214	26	441	2	--	87	70	114	271	4	--	22	281	127	430	1	1254	9
Cars % of Movement	0.0%	96.3%	100%	94.1%	98.2%	22.2%	0.0%	100%	98.2%	100%	99.1%	22.2%	0.0%	100%	98.6%	100%	99.6%	44.4%	0.0%	95.7%	99.3%	100%	99.3%	11.1%	99.2%	
Trucks Total	--	1	--	1	2	--	--	--	4	--	4	--	--	--	1	--	1	--	--	1	2	--	3	--	10	--
Trucks % of Movement	0.0%	3.7%	0.0%	5.9%	1.8%	--	0.0%	0.0%	1.8%	0.0%	0.9%	--	0.0%	0.0%	1.4%	0.0%	0.4%	--	0.0%	4.3%	0.7%	0.0%	0.7%	--	0.8%	

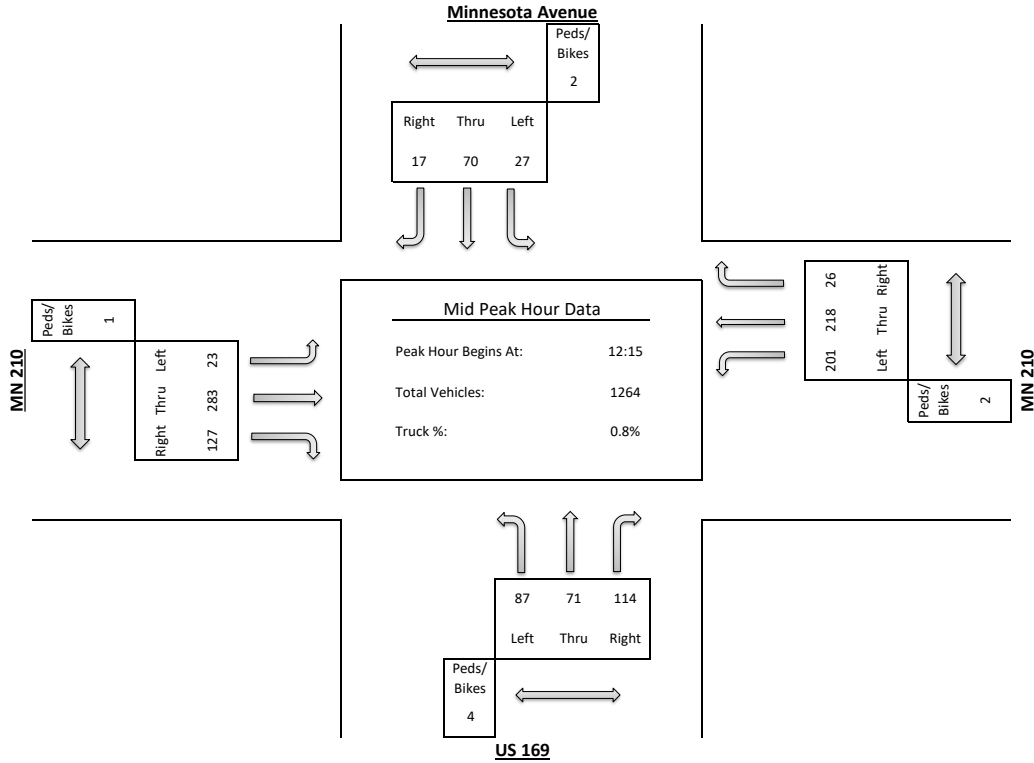

ALLIANT ENGINEERING, INC.

733 S Marquette Ave #700, Minneapolis, MN 55402

Intersection: US 169 & MN 210 (W Jct)
 Date: 5/11/2025
 Duration: 0600-1900

Site Code: 200
 Ref Pt: N/A
 Page No: 4 of 4

All Vehicles (Cars & Trucks) Printed

Start Time	Minnesota Avenue Southbound						MN 210 Westbound						US 169 Northbound						MN 210 Eastbound						Int. Veh. Total	Int. Ped/Bike Total
	U-Turn	Left	Thru	Right	App. Total	Peds/Bikes	U-Turn	Left	Thru	Right	App. Total	Peds/Bikes	U-Turn	Left	Thru	Right	App. Total	Peds/Bikes	U-Turn	Left	Thru	Right	App. Total	Peds/Bikes		
14:30	--	6	15	3	24	--	--	44	46	3	93	--	--	17	10	21	48	--	--	5	46	26	77	--	242	--
14:45	--	3	14	5	22	2	--	27	47	5	79	2	--	20	9	24	53	--	--	1	43	26	70	4	224	8
15:00	--	6	11	1	18	--	--	36	37	3	76	1	--	22	16	34	72	--	--	3	43	28	74	--	240	1
15:15	--	7	15	3	25	--	--	37	40	5	82	--	--	27	15	23	65	1	--	3	31	13	47	1	219	2
Hour Total	--	22	55	12	89	2	--	144	170	16	330	3	--	86	50	102	238	1	--	12	163	93	268	5	925	11
% of App.	0.0%	24.7%	61.8%	13.5%			0.0%	43.6%	51.5%	4.8%			0.0%	36.1%	21.0%	42.9%			0.0%	4.5%	60.8%	34.7%				
% of Total	0.0%	2.4%	5.9%	1.3%	9.6%	18.2%	0.0%	15.6%	18.4%	1.7%	35.7%	27.3%	0.0%	9.3%	5.4%	11.0%	25.7%	9.1%	0.0%	1.3%	17.6%	10.1%	29.0%	45.5%		
Cars Total	--	21	55	12	88	2	--	144	166	16	326	3	--	85	50	102	237	1	--	12	162	93	267	5	918	11
Cars % of Movement	0.0%	95.5%	100%	100%	98.9%	18.2%	0.0%	100%	97.6%	100%	98.8%	27.3%	0.0%	98.8%	100%	100%	99.6%	9.1%	0.0%	100%	99.4%	100%	99.6%	45.5%	99.2%	
Trucks Total	--	1	--	--	1	--	--	--	4	--	4	--	--	1	--	--	1	--	--	--	1	--	1	--	7	--
Trucks % of Movement	0.0%	4.5%	0.0%	0.0%	1.1%	--	0.0%	0.0%	2.4%	0.0%	1.2%	--	0.0%	1.2%	0.0%	0.4%	--	--	0.0%	0.0%	0.6%	0.0%	0.4%	--	0.8%	

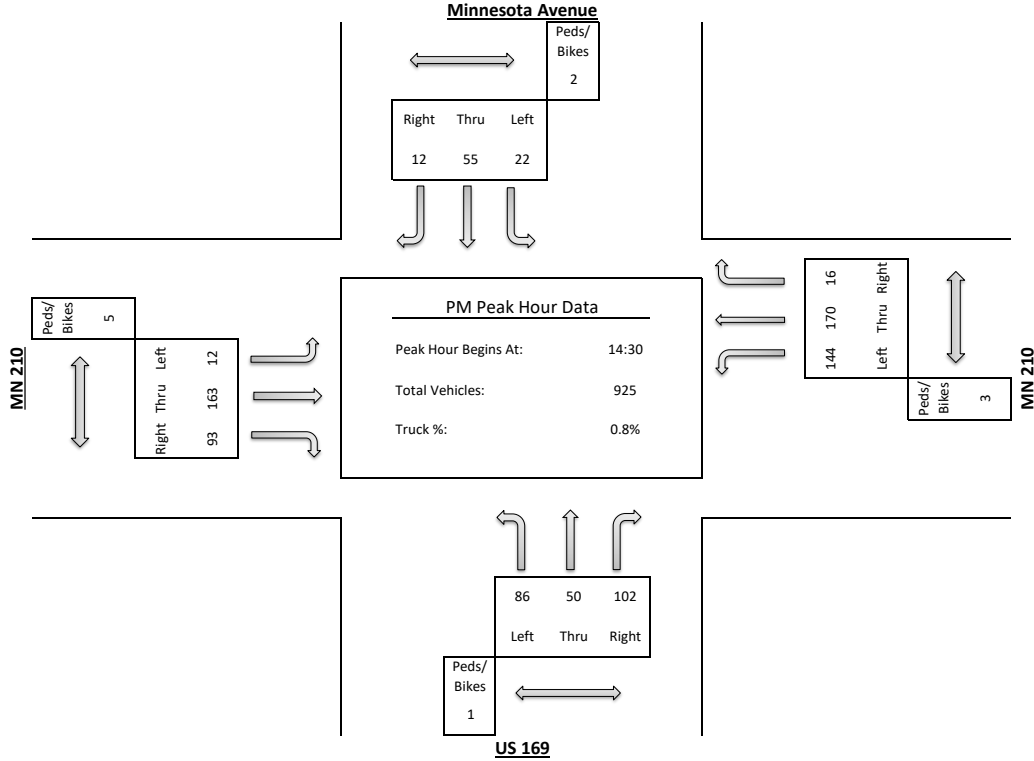

APPENDIX B: TRAFFIC FORECASTING RESULTS

MN 210

East Leg

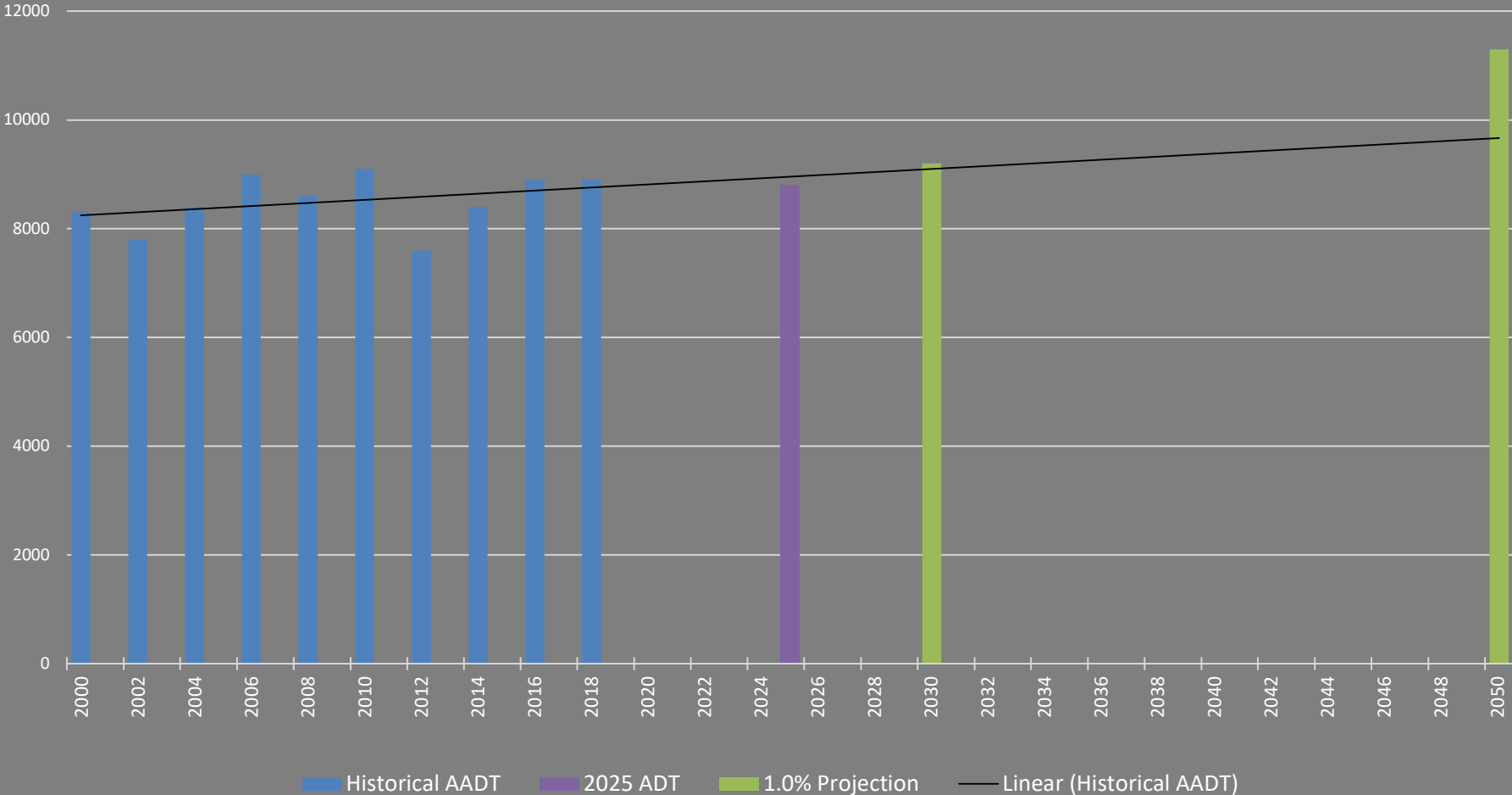

MN 210

West Leg

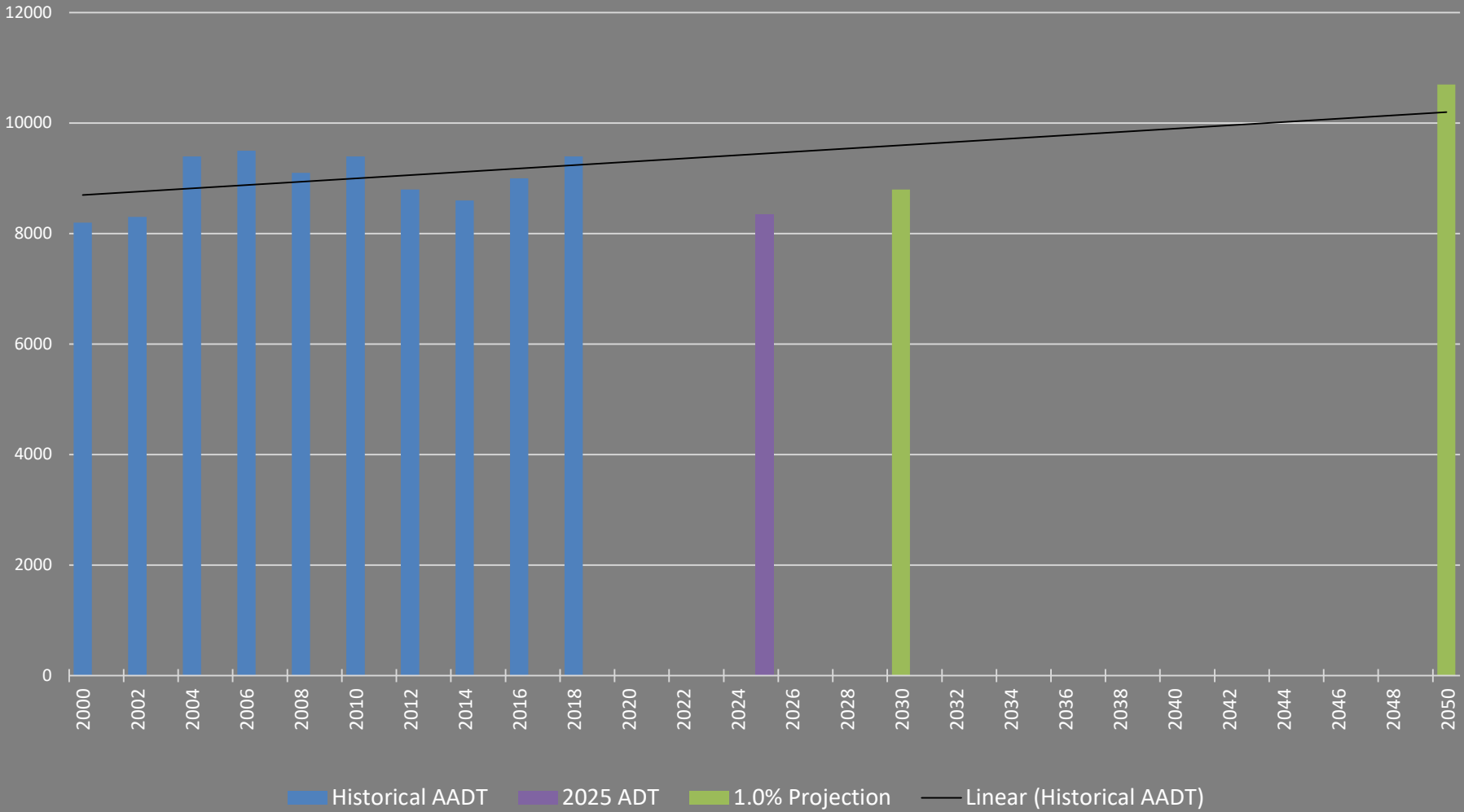

Minnesota Ave N

North Leg

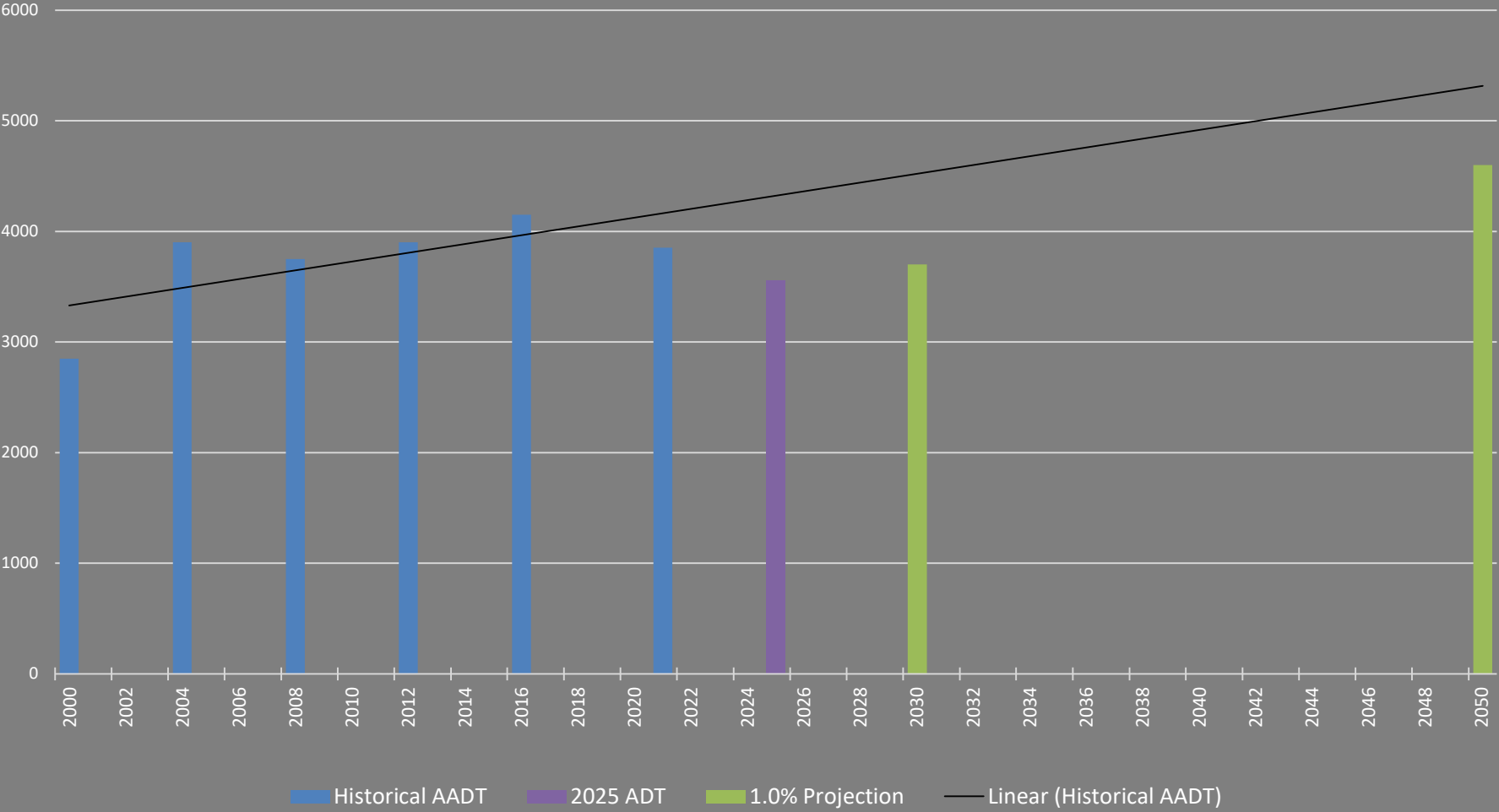

US 169

South Leg

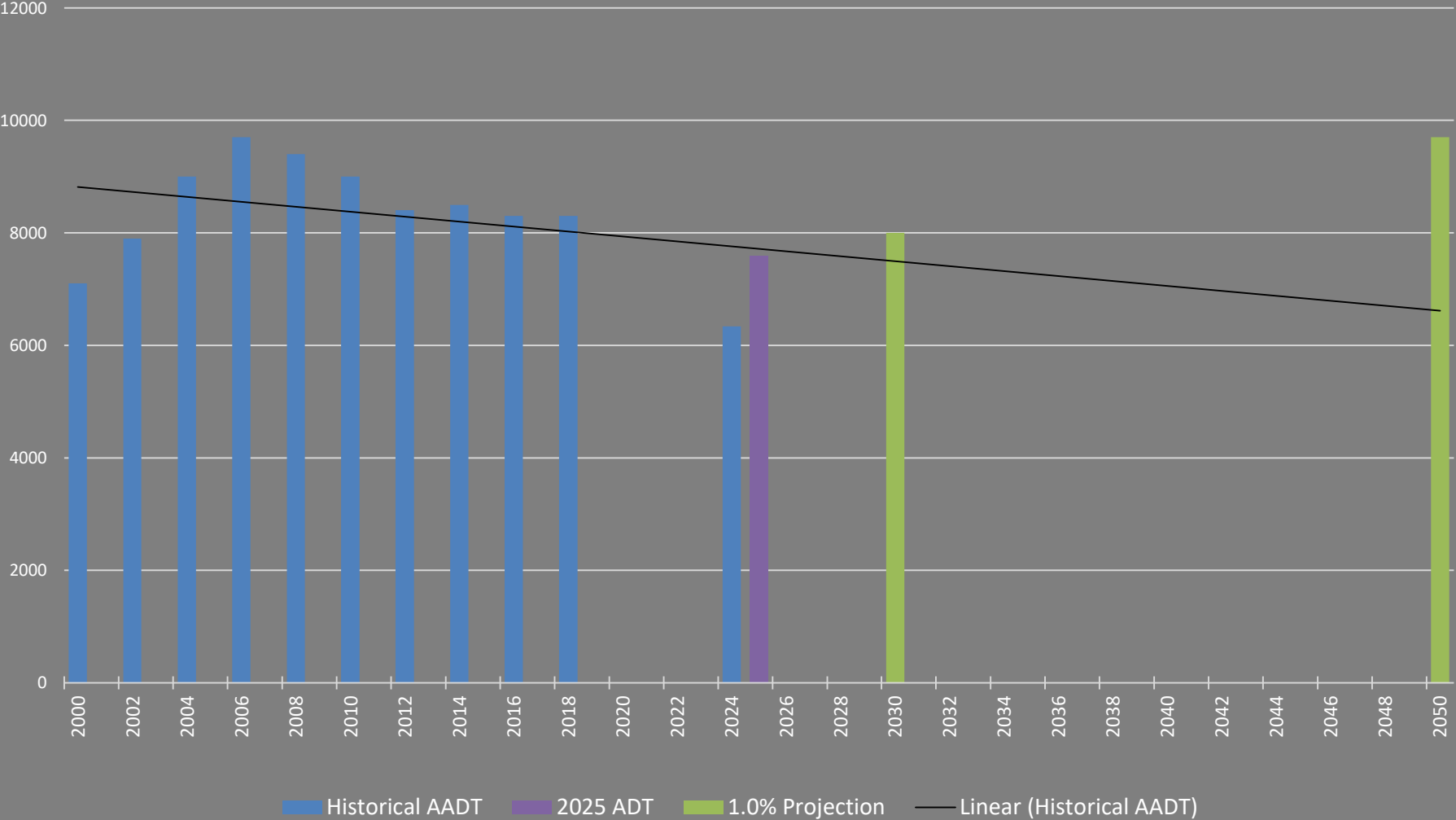

LEAST SQUARES WORKSHEET

SEGMENT A1

ROUTE: _____ SP#: _____ DATE : 07/22/25
 LOCATION: MN 210 (East Leg) at US 169 Seq # 74
 BASE YEAR: 2025 FORECAST YEAR: 2050 # of lanes 2

COUNTED YEAR	FLOW MAP AADT (SEG A)
1992	5900
1994	7800
1996	6300
1998	7700
2000	8300
2002	7800
2004	8400
2006	9000
2008	8600
2010	9100
2012	7600
2014	8400
2016	8900
2018	8900

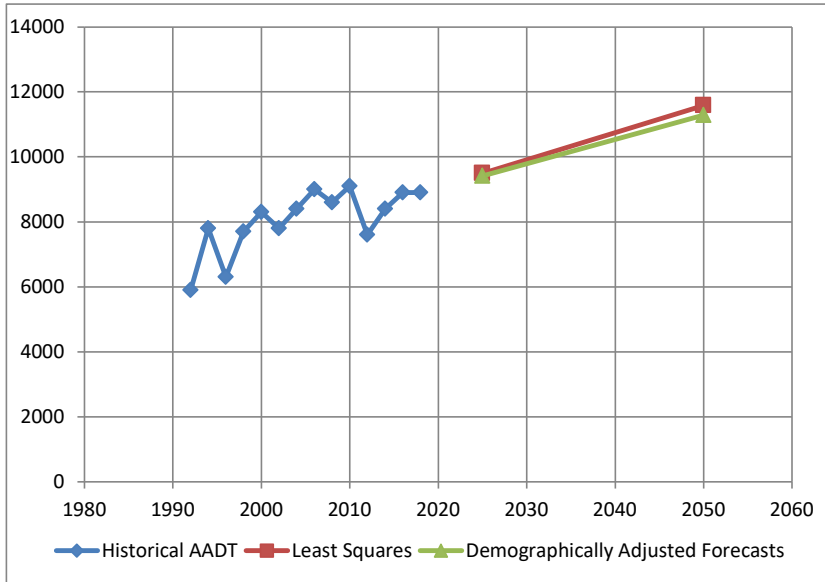

LEAST SQUARES BASED FORECASTS:

Year	AAADT	Calc	ADT Calc
2018	9140	-240	8900
2025	9727		9487
2050	11823		11583

Statistics	AAADT
R 2	0.52
SLOPE	83.85
INTERCEPT	-160062
N	14

Raw Least Squares Forecasts	
YEAR	AAADT
2018	8900
2025	9490
2050	11580

Slope Over Base Year
0.88%

Demographically Adjusted Forecasts	
YEAR	AAADT
2018	8900
2025	9420
2050	11290

Slope Over Base Year
0.79%

NOTE:
 County Adjustment Factors were developed to Apply to Projected AADT. They are based on 1992-2007 VMT, Population, Labor Force, Household, and Employment Data.

COUNTY	COUNTY FACTOR	GROWTH PROFILE
AITKIN	0.95	HIGH GROWTH AREA

LEAST SQUARES WORKSHEET

SEGMENT B1

Corresponds : SEGMENT A1

ROUTE: _____

SP#: _____

DATE : 07/22/25

LOCATION: MN 210 (West Leg) at US 169

Seq # 73

BASE YEAR: 2025

FORECAST YEAR: 2050

of lanes 2

COUNTED YEAR	FLOW MAP AADT (SEG A)
1994	7800
1996	6100
1998	6600
2000	8200
2002	8300
2004	9400
2006	9500
2008	9100
2010	9400
2012	8800
2014	8600
2016	9000
2018	9400

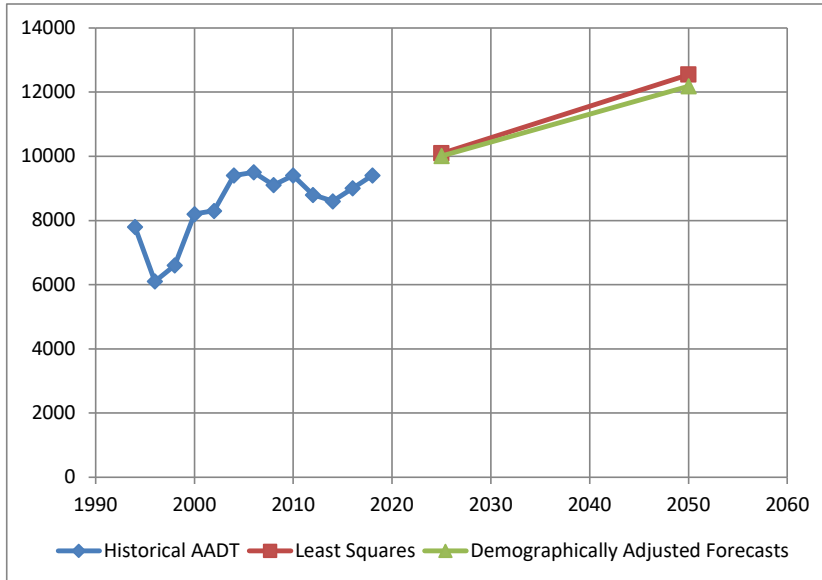

LEAST SQUARES BASED FORECASTS:

Year	AAADT	Calc	ADT Calc
2018	9657	-257	9400
2025	10346		10088
2050	12804		12547

Statistics	AAADT
R 2	0.50
SLOPE	98.35
INTERCEPT	-188816
N	13

Raw Least Squares Forecasts	
YEAR	AAADT
2018	9400
2025	10090
2050	12550

Slope Over Base Year
0.97%

Demographically Adjusted Forecasts	
YEAR	AAADT
2018	9400
2025	10010
2050	12190

Slope Over Base Year
0.87%

NOTE:
County Adjustment Factors were developed to Apply to Projected AADT. They are based on 1992-2007 VMT, Population, Labor Force, Household, and Employment Data.

COUNTY	COUNTY FACTOR	GROWTH PROFILE
AITKIN	0.95	HIGH GROWTH AREA

LEAST SQUARES WORKSHEET

SEGMENT B3

Corresponds : SEGMENT A1

ROUTE: _____

SP#: _____

DATE : 07/22/25

LOCATION: US 169 (South Leg) at MN 210

Seq # 72

BASE YEAR: 2025

FORECAST YEAR: 2050

of lanes 2

COUNTED YEAR	FLOW MAP AADT (SEG A)
1994	7900
1996	8100
1998	7600
2000	7100
2002	7900
2004	9000
2006	9700
2008	9400
2010	9000
2012	8400
2014	8500
2016	8300
2018	8300
2024	6337

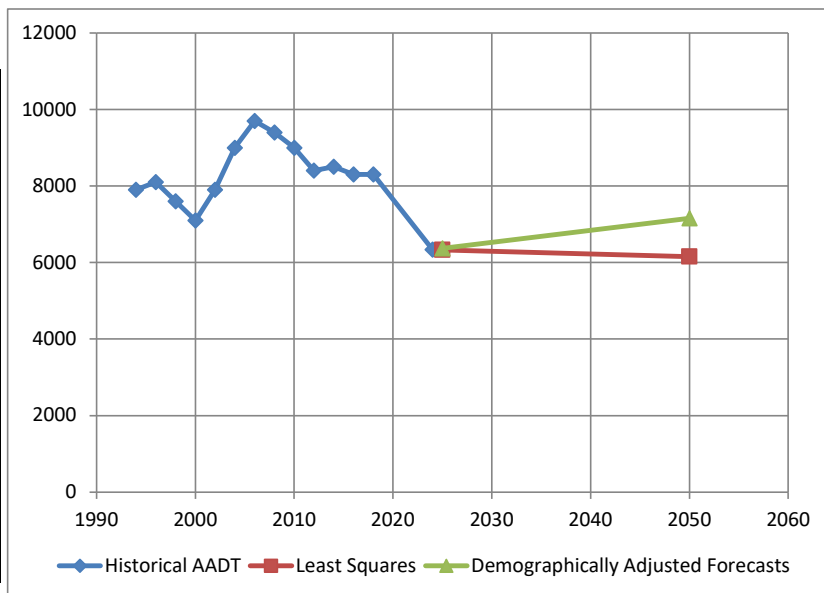

LEAST SQUARES BASED FORECASTS:

Year	AADT	Calc	ADT Calc
2024	8131	-1794	6337
2025	8124		6330
2050	7942		6148

Statistics	AADT
R 2	0.01
SLOPE	-7.27
INTERCEPT	22849
N	14

Raw Least Squares Forecasts	
YEAR	AADT
2024	6340
2025	6330
2050	6150

Slope Over Base Year
-0.11%

Demographically Adjusted Forecasts	
YEAR	AADT
2024	6340
2025	6370
2050	7160

Slope Over Base Year
0.50%

NOTE:
County Adjustment Factors were developed to Apply to Projected AADT. They are based on 1992-2007 VMT, Population, Labor Force, Household, and Employment Data.

COUNTY	COUNTY FACTOR	GROWTH PROFILE
AITKIN	0.95	HIGH GROWTH AREA

APPENDIX C: EXISTING & NO BUILD MOE

Existing Year 2025 Conditions - AM Peak Hour

Intersection	MOE	Eastbound Approach			Westbound Approach			Northbound Approach			Southbound Approach			Intersection Total
		EBL	EBT	EBR	WBL	WBT	WBR	NBL	NBT	NBR	SBL	SBT	SBR	
US 169 & MN 210	Movement Delay (sec/veh)	24.3	25.5	16.6	28.7	27.4	20.9	31.1	31.2	18.5	22.8	22.7	9.8	24.8
	Total Delay (hr)	0.1	1.2	0.6	0.6	1.7	0.2	0.8	1.0	0.3	0.1	0.8	0.1	7.5
	Movement LOS	C	C	B	C	C	C	C	C	B	C	C	A	C
	Movement Volume	16	171	134	77	208	34	90	118	62	22	117	23	1072
	Movement 95th Queue (ft)	227	227	57	220	220	46	261	261	57	162	162	45	
	Storage Bay Distance (ft)	0	0	25	0	0	25	0	0	25	0	0	25	
	Approach Delay (sec/veh)	21.7			27.0			28.3			20.9			
Approach LOS	C			C			C			C				

Existing Year 2025 Conditions - PM Peak Hour

Intersection	MOE	Eastbound Approach			Westbound Approach			Northbound Approach			Southbound Approach			Intersection Total
		EBL	EBT	EBR	WBL	WBT	WBR	NBL	NBT	NBR	SBL	SBT	SBR	
US 169 & MN 210	Movement Delay (sec/veh)	27.1	29.3	20.0	27.9	27.8	22.7	33.9	33.4	20.4	25.0	22.4	8.4	26.7
	Total Delay (hr)	0.2	2.1	0.7	0.9	1.7	0.1	1.2	0.9	0.6	0.3	0.6	0.1	9.4
	Movement LOS	C	C	B	C	C	C	C	C	C	C	C	A	C
	Movement Volume	30	246	111	103	211	15	123	92	103	38	102	31	1205
	Movement 95th Queue (ft)	274	274	57	230	230	32	251	251	56	160	160	50	
	Storage Bay Distance (ft)	0	0	25	0	0	25	0	0	25	0	0	25	
	Approach Delay (sec/veh)	26.5			27.6			29.4			20.4			
Approach LOS	C			C			C			C				

Existing Year 2025 Conditions - FRI Peak Hour

Intersection	MOE	Eastbound Approach			Westbound Approach			Northbound Approach			Southbound Approach			Intersection Total
		EBL	EBT	EBR	WBL	WBT	WBR	NBL	NBT	NBR	SBL	SBT	SBR	
US 169 & MN 210	Movement Delay (sec/veh)	43.4	43.3	36.0	89.1	82.2	76.5	56.9	61.0	43.4	47.0	42.2	22.0	56.2
	Total Delay (hr)	0.3	3.6	1.4	3.6	6.4	0.7	2.2	2.4	2.2	0.7	1.9	0.1	25.5
	Movement LOS	D	D	D	F	F	E	E	E	D	D	D	C	E
	Movement Volume	27	287	136	137	259	32	132	138	176	55	157	24	1560
	Movement 95th Queue (ft)	469	469	54	793	793	47	578	578	58	282	282	45	
	Storage Bay Distance (ft)	0	0	25	0	0	25	0	0	25	0	0	25	
	Approach Delay (sec/veh)	41.1			84.0			52.8			41.3			
Approach LOS	D			F			D			D				

Existing Year 2025 Conditions - SUN Peak Hour

Intersection	MOE	Eastbound Approach			Westbound Approach			Northbound Approach			Southbound Approach			Intersection Total
		EBL	EBT	EBR	WBL	WBT	WBR	NBL	NBT	NBR	SBL	SBT	SBR	
US 169 & MN 210	Movement Delay (sec/veh)	32.5	29.8	21.5	44.1	42.6	39.1	37.7	36.9	23.7	32.4	28.6	8.8	33.8
	Total Delay (hr)	0.2	2.6	0.8	2.9	2.9	0.3	1.1	0.9	0.8	0.3	0.6	0.0	13.4
	Movement LOS	C	C	C	D	D	D	D	D	C	C	C	A	C
	Movement Volume	26	306	138	217	229	27	97	79	117	30	70	18	1354
	Movement 95th Queue (ft)	321	321	52	395	395	44	247	247	57	123	123	39	
	Storage Bay Distance (ft)	0	0	25	0	0	25	0	0	25	0	0	25	
	Approach Delay (sec/veh)	27.5			43.1			31.9			26.5			
Approach LOS	C			D			C			C				

Forecast Year 2030 No Build Conditions - AM Peak Hour

Intersection	MOE	Eastbound Approach			Westbound Approach			Northbound Approach			Southbound Approach			Intersection Total
		EBL	EBT	EBR	WBL	WBT	WBR	NBL	NBT	NBR	SBL	SBT	SBR	
US 169 & MN 210	Movement Delay (sec/veh)	23.7	27.1	17.0	32.1	29.8	22.1	28.2	31.3	18.0	25.2	22.1	10.0	25.7
	Total Delay (hr)	0.1	1.4	0.7	0.8	2.0	0.3	0.7	1.1	0.3	0.2	0.8	0.1	8.5
	Movement LOS	C	C	B	C	C	C	C	C	B	C	C	A	C
	Movement Volume	20	179	134	81	229	40	91	123	63	24	126	23	1133
	Movement 95th Queue (ft)	245	245	58	267	267	47	244	244	57	159	159	47	
	Storage Bay Distance (ft)	0	0	25	0	0	25	0	0	25	0	0	25	
	Approach Delay (sec/veh)		22.8			29.5			27.3			20.9		
Approach LOS		C			C			C			C			

Forecast Year 2030 No Build Conditions - PM Peak Hour

Intersection	MOE	Eastbound Approach			Westbound Approach			Northbound Approach			Southbound Approach			Intersection Total
		EBL	EBT	EBR	WBL	WBT	WBR	NBL	NBT	NBR	SBL	SBT	SBR	
US 169 & MN 210	Movement Delay (sec/veh)	28.4	32.6	21.9	33.8	32.9	25.1	35.7	36.2	25.4	25.8	21.7	10.4	29.8
	Total Delay (hr)	0.3	2.4	0.7	1.0	2.1	0.1	1.4	1.1	0.8	0.3	0.7	0.1	11.0
	Movement LOS	C	C	C	C	C	C	D	D	C	C	C	B	C
	Movement Volume	31	252	117	102	222	18	135	105	109	43	108	36	1278
	Movement 95th Queue (ft)	303	303	54	267	267	36	310	310	57	162	162	55	
	Storage Bay Distance (ft)	0	0	25	0	0	25	0	0	25	0	0	25	
	Approach Delay (sec/veh)		29.1			32.8			32.6			20.5		
Approach LOS		C			C			C			C			

Forecast Year 2030 No Build Conditions - FRI Peak Hour

Intersection	MOE	Eastbound Approach			Westbound Approach			Northbound Approach			Southbound Approach			Intersection Total
		EBL	EBT	EBR	WBL	WBT	WBR	NBL	NBT	NBR	SBL	SBT	SBR	
US 169 & MN 210	Movement Delay (sec/veh)	49.4	44.5	34.0	153.6	149.2	135.1	74.1	78.0	61.3	56.9	53.1	29.5	81.2
	Total Delay (hr)	0.4	3.9	1.4	7.0	12.2	1.5	3.1	3.2	3.3	0.9	2.6	0.2	39.7
	Movement LOS	D	D	C	F	F	F	E	E	E	E	D	C	F
	Movement Volume	25	304	141	151	272	36	140	141	185	57	171	29	1652
	Movement 95th Queue (ft)	467	467	54	1340	1340	49	685	685	60	401	401	45	
	Storage Bay Distance (ft)	0	0	25	0	0	25	0	0	25	0	0	25	
	Approach Delay (sec/veh)		41.6			149.5			70.2			51.3		
Approach LOS		D			F			E			D			

Forecast Year 2030 No Build Conditions - SUN Peak Hour

Intersection	MOE	Eastbound Approach			Westbound Approach			Northbound Approach			Southbound Approach			Intersection Total
		EBL	EBT	EBR	WBL	WBT	WBR	NBL	NBT	NBR	SBL	SBT	SBR	
US 169 & MN 210	Movement Delay (sec/veh)	34.9	31.6	24.0	63.7	60.5	56.5	44.5	42.9	26.4	38.4	32.6	13.7	42.3
	Total Delay (hr)	0.3	2.9	1.0	4.3	4.3	0.5	1.3	1.0	1.0	0.3	0.7	0.1	17.7
	Movement LOS	C	C	C	E	E	E	D	D	C	D	C	B	D
	Movement Volume	27	319	145	224	241	29	102	81	128	32	79	25	1432
	Movement 95th Queue (ft)	378	378	52	550	550	45	287	287	54	143	143	43	
	Storage Bay Distance (ft)	0	0	25	0	0	25	0	0	25	0	0	25	
	Approach Delay (sec/veh)		29.5			61.7			36.6			30.5		
Approach LOS		C			E			D			C			

Forecast Year 2050 No Build Conditions - AM Peak Hour

Intersection	MOE	Eastbound Approach			Westbound Approach			Northbound Approach			Southbound Approach			Intersection Total
		EBL	EBT	EBR	WBL	WBT	WBR	NBL	NBT	NBR	SBL	SBT	SBR	
US 169 & MN 210	Movement Delay (sec/veh)	30.6	34.7	27.0	59.3	54.9	49.2	43.8	48.7	30.4	29.5	27.2	14.9	40.5
	Total Delay (hr)	0.2	2.2	1.4	1.7	4.3	0.6	1.5	2.0	0.7	0.2	1.1	0.1	16.0
	Movement LOS	C	C	C	E	D	D	D	D	C	C	C	B	D
	Movement Volume	27	224	177	97	271	41	120	147	77	30	148	25	1384
	Movement 95th Queue (ft)	359	359	62	550	550	52	406	406	58	204	204	52	
	Storage Bay Distance (ft)	0	0	25	0	0	25	0	0	25	0	0	25	
	Approach Delay (sec/veh)	31.3			55.4			42.9			26.0			
Approach LOS	C			E			D			C				

Forecast Year 2050 No Build Conditions - PM Peak Hour

Intersection	MOE	Eastbound Approach			Westbound Approach			Northbound Approach			Southbound Approach			Intersection Total
		EBL	EBT	EBR	WBL	WBT	WBR	NBL	NBT	NBR	SBL	SBT	SBR	
US 169 & MN 210	Movement Delay (sec/veh)	39.9	42.0	31.1	92.1	86.9	79.4	56.5	56.9	45.2	41.8	37.8	23.1	55.5
	Total Delay (hr)	0.4	3.8	1.3	3.8	6.9	0.5	2.7	2.1	1.7	0.6	1.5	0.3	25.6
	Movement LOS	D	D	C	F	F	E	E	E	D	D	D	C	E
	Movement Volume	39	314	145	134	271	20	164	126	128	50	137	43	1571
	Movement 95th Queue (ft)	459	459	52	690	690	41	477	477	58	260	260	55	
	Storage Bay Distance (ft)	0	0	25	0	0	25	0	0	25	0	0	25	
	Approach Delay (sec/veh)	38.7			88.2			53.2			35.9			
Approach LOS	D			F			D			D				

Forecast Year 2050 No Build Conditions - FRI Peak Hour

Intersection	MOE	Eastbound Approach			Westbound Approach			Northbound Approach			Southbound Approach			Intersection Total
		EBL	EBT	EBR	WBL	WBT	WBR	NBL	NBT	NBR	SBL	SBT	SBR	
US 169 & MN 210	Movement Delay (sec/veh)	59.3	57.7	47.6	757.1	717.0	722.4	499.5	449.0	463.0	110.1	99.5	67.1	364.6
	Total Delay (hr)	0.6	6.0	2.3	41.4	74.9	8.6	25.8	24.1	29.8	2.4	5.8	0.6	222.3
	Movement LOS	E	E	D	F	F	F	F	F	F	F	F	E	F
	Movement Volume	33	364	164	172	329	39	175	183	222	78	208	32	1999
	Movement 95th Queue (ft)	681	681	56	5743	5743	47	3802	3802	62	798	798	46	
	Storage Bay Distance (ft)	0	0	25	0	0	25	0	0	25	0	0	25	
	Approach Delay (sec/veh)	54.8			730.2			469.6			98.8			
Approach LOS	D			F			F			F				

Forecast Year 2050 No Build Conditions - SUN Peak Hour

Intersection	MOE	Eastbound Approach			Westbound Approach			Northbound Approach			Southbound Approach			Intersection Total
		EBL	EBT	EBR	WBL	WBT	WBR	NBL	NBT	NBR	SBL	SBT	SBR	
US 169 & MN 210	Movement Delay (sec/veh)	47.7	45.4	38.1	552.6	509.5	543.5	53.4	53.8	39.1	46.7	43.5	21.0	210.9
	Total Delay (hr)	0.4	5.1	1.9	44.4	45.1	5.3	1.9	1.6	1.8	0.5	1.2	0.2	109.4
	Movement LOS	D	D	D	F	F	F	D	D	D	D	D	C	F
	Movement Volume	30	393	171	266	291	34	121	97	162	39	95	27	1726
	Movement 95th Queue (ft)	585	585	53	4414	4414	45	412	412	55	209	209	45	
	Storage Bay Distance (ft)	0	0	25	0	0	25	0	0	25	0	0	25	
	Approach Delay (sec/veh)	43.4			530.9			47.4			40.5			
Approach LOS	D			F			D			D				

APPENDIX D: SIGNAL WARRANT ANALYSIS RESULTS

TRAFFIC CONTROL WARRANTS ANALYSIS

2025 MnDOT District 3 ICE Reports, US 169 & MN 210 (W JCT)

2025 Existing

Background	Project Data			Analysis	Volumes	Direction	Analysis Approach			Roadway			Speed	Lanes	RT %
	Project: 2025 MnDOT District 3 ICE Reports			Date: 7/18/2025	Scenario: 2025 Existing	WB	Major Approach 1			US 169 / MN 210			30	1	100%
	Intersection: US 169 & MN 210 (W JCT)					EB	Major Approach 3			MN 210			30	1	100%
	Population < 10,000?	YES	Exist. Traffic Control:	Analyst: CPH	Format: 15 MIN	NB	Minor Approach 2			US 169			30	1	100%
70% Factor Used:	YES	Signal			SB	Minor Approach 4			Minnesota Avenue N			30	1	100%	

Hour	Major Approaches					Minor Approaches					Traffic Signal Warrants					Existing Signal Justification						AWSC Warrants		
	Approach			Volumes Met		Approach			Volumes Met		8-Hour			4-Hr	Peak	60%			80%			C1	C2	80% of C1&C2
	WB	EB	Total	A	B	NB	SB	Max	A	B	1A	1B	1C (1A/1B)	2	3B	1A	1B	1C (1A/1B)	1A	1B	1C (1A/1B)	300	200	D
	1	3		350	525	2	4		105	53														
12 - 1 AM	11	11	22			12	7	12																
1 - 2 AM	4	10	14			5	2	5																
2 - 3 AM	12	4	16			4	1	4																
3 - 4 AM	5	10	15			3	4	4																
4 - 5 AM	19	13	32			6	4	6																
5 - 6 AM	62	69	131			40	20	40																
6 - 7 AM	122	130	252			89	38	89							X		X/X			X/-				
7 - 8 AM	281	278	559	X	X	213	127	213	X	X	X	X	X/X	X	X	X	X	X/X	X	X	X/X	X	X	X
8 - 9 AM	291	254	545	X	X	269	145	269	X	X	X	X	X/X	X	X	X	X	X/X	X	X	X/X	X	X	X
9 - 10 AM	309	270	579	X	X	239	138	239	X	X	X	X	X/X	X	X	X	X	X/X	X	X	X/X	X	X	X
10 - 11 AM	277	217	494	X		274	106	274	X	X	X		X/X	X	X	X	X	X/X	X	X	X/X	X	X	X
11 - Noon	333	297	630	X	X	298	156	298	X	X	X	X	X/X	X	X	X	X	X/X	X	X	X/X	X	X	X
12 - 1 PM	343	296	639	X	X	267	147	267	X	X	X	X	X/X	X	X	X	X	X/X	X	X	X/X	X	X	X
1 - 2 PM	338	333	671	X	X	251	122	251	X	X	X	X	X/X	X	X	X	X	X/X	X	X	X/X	X	X	X
2 - 3 PM	338	354	692	X	X	277	143	277	X	X	X	X	X/X	X	X	X	X	X/X	X	X	X/X	X	X	X
3 - 4 PM	319	375	694	X	X	339	179	339	X	X	X	X	X/X	X	X	X	X	X/X	X	X	X/X	X	X	X
4 - 5 PM	362	365	727	X	X	308	153	308	X	X	X	X	X/X	X	X	X	X	X/X	X	X	X/X	X	X	X
5 - 6 PM	287	279	566	X	X	252	124	252	X	X	X	X	X/X	X	X	X	X	X/X	X	X	X/X	X	X	X
6 - 7 PM	203	208	411	X		158	63	158	X	X	X		X/-	X			X/X	X		X/X	X	X	X	X
7 - 8 PM	123	152	275			172	53	172	X	X					X		X/X			X/-		X	X	X
8 - 9 PM	109	150	259			131	43	131	X	X					X		X/X			X/-			X	X
9 - 10 PM	94	83	177			66	18	66		X							X/-							X
10 - 11 PM	46	64	110			37	25	37									X/-							
11 - Midnight	38	37	75			28	5	28																

Summary	Signal Warrants ¹				Existing Signal Justification ²				Met 60%	Met 80%	Req'd	Justification Criteria Met?	
	Met	Req'd	Warrant Met?		Met 60%	Met 80%	Req'd						
Warrant 1					Existing Signal Justification: Reduced Warrant 1A				15	12	8	JUSTIFIED	
1A: 8-Hour (Minimum Vehicular Volume)	12	8	MET		Existing Signal Justification: Reduced Warrant 1B				12	11	8	JUSTIFIED MET	
1B: 8-Hour (Interruption of Continuous Traffic)	10	8	MET	MET	Existing Signal Justification: Reduced Warrant 1C				15	12	8	JUSTIFIED	
1C: 8-Hour (Combination of 1A & 1B at 80%)	11	8	MET		All-Way Stop Warrants¹				Met	Req'd.	Warrant Met?		
Warrant 2: 4-Hour	12	4	MET	MET	All-Way Stop: Crit. A (Signal Justified)				3	1	MET		
Warrant 3B: Peak Hour	11	1	MET	MET	All-Way Stop: Crit. B (Crash History)				3	5	NO		
Warrant 7					All-Way Stop: Crit. C1 & C2 (Min Vols, Same Hrs)				12	8	MET		
7B: Crash History	3	5	NO		All-Way Stop: Crit. C2 (Minor App. Delay)				29.4	30	NO		
7C: Condition A or Condition B (80%)	12	8	MET	NO	All-Way Stop: Crit. D (80% of B, C1, & C2)				-	-	NO		

¹ Source: U.S. Dept. of Transportation FHWA Manual on Uniform Traffic Control Devices (2009 Edition)

² Source: MnDOT Traffic Engineering Manual, Chapter 9-5.02.05 "Traffic Control Signal Removal Justification Criteria"

TRAFFIC CONTROL WARRANTS ANALYSIS

2025 MnDOT District 3 ICE Reports, US 169 & MN 210 (W JCT)

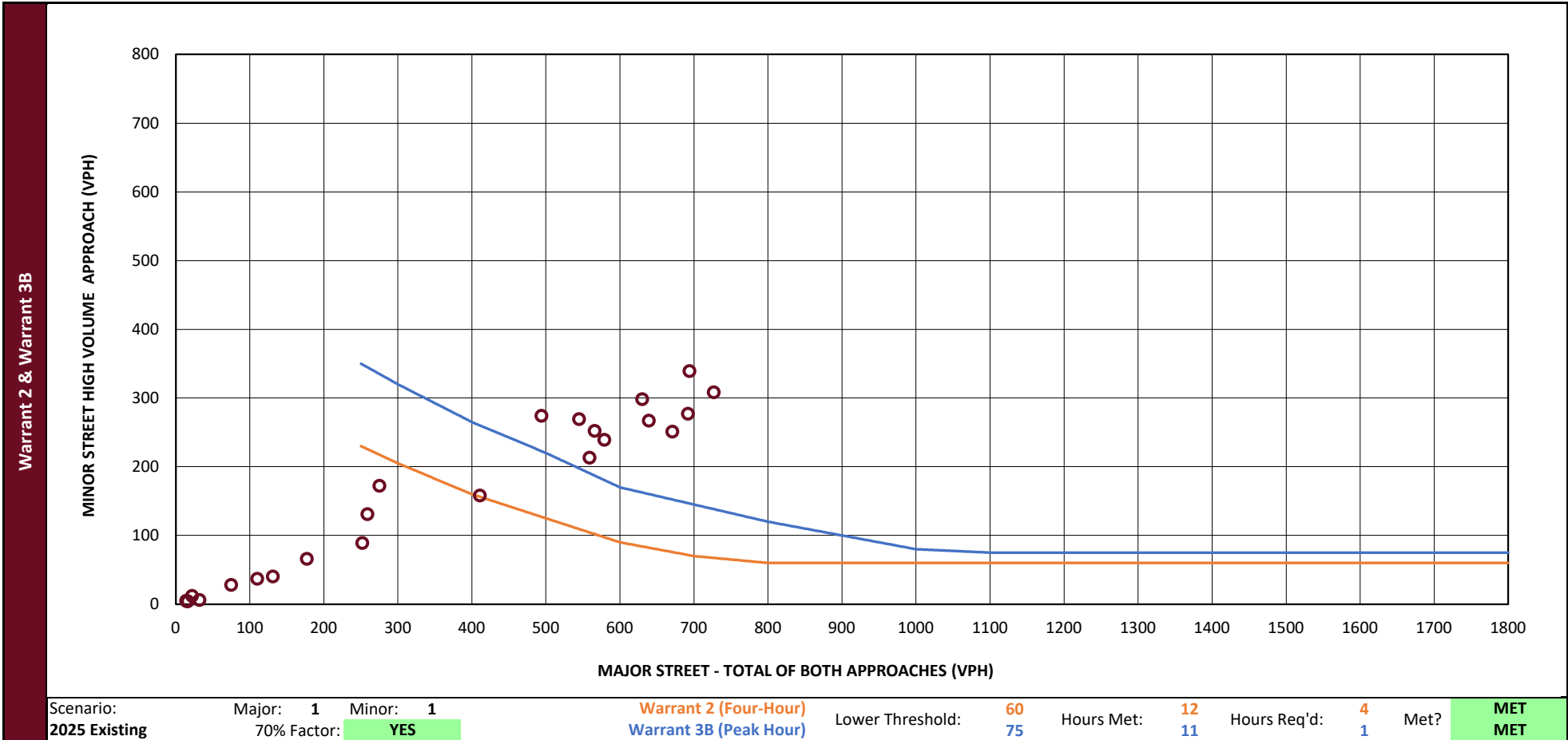

Source: U.S. Department of Transportation FHWA Manual on Uniform Traffic Control Devices (2009 Edition)

Warrant 2 (Four-Hour) Notes:

100%: 115 vph applies as the lower threshold volume for a minor-street approach with two or more lanes and 80 vph applies as the lower threshold volume for a minor-street approach with one lane.
 70%: 80 vph applies as the lower threshold volume for a minor-street approach with two or more lanes and 60 vph applies as the lower threshold volume for a minor-street approach with one lane.

Warrant 3B (Peak Hour) Notes:

100%: 150 vph applies as the lower threshold volume for a minor-street approach with two or more lanes and 100 vph applies as the lower threshold volume for a minor-street approach with one lane.
 70%: 100 vph applies as the lower threshold volume for a minor-street approach with two or more lanes and 75 vph applies as the lower threshold volume for a minor-street approach with one lane.

TRAFFIC CONTROL WARRANTS ANALYSIS

2025 MnDOT District 3 ICE Reports, US 169 & MN 210 (W JCT)

2030 No Build

Background	Project Data			Analysis	Volumes	Direction	Analysis Approach			Roadway			Speed	Lanes	RT %
	Project: 2025 MnDOT District 3 ICE Reports			Date: 7/18/2025	Scenario: 2030 No Build	WB	Major Approach 1			US 169 / MN 210			30	1	100%
	Intersection: US 169 & MN 210 (W JCT)					EB	Major Approach 3			MN 210			30	1	100%
	Population < 10,000?	YES	Exist. Traffic Control:	Analyst: CPH	Format: 15 MIN	NB	Minor Approach 2			US 169			30	1	100%
70% Factor Used:	YES	Signal			SB	Minor Approach 4			Minnesota Avenue N			30	1	100%	

Hour	Major Approaches					Minor Approaches					Traffic Signal Warrants					Existing Signal Justification						AWSC Warrants		
	Approach			Volumes Met		Approach			Volumes Met		8-Hour			4-Hr	Peak	60%			80%			C1	C2	80% of C1&C2
	WB	EB	Total	A	B	NB	SB	Max	A	B	1A	1B	1C (1A/1B)	2	3B	1A	1B	1C (1A/1B)	1A	1B	1C (1A/1B)	300	200	D
	1	3		350	525	2	4		105	53														
12 - 1 AM	11	11	22			12	8	12																
1 - 2 AM	4	10	14			5	2	5																
2 - 3 AM	13	4	17			4	1	4																
3 - 4 AM	5	11	16			3	4	4																
4 - 5 AM	21	14	35			6	4	6																
5 - 6 AM	68	75	143			44	21	44																
6 - 7 AM	130	138	268			97	41	97		X					X		X/X			X/-				
7 - 8 AM	298	295	593	X	X	226	136	226	X	X	X	X	X/X	X	X	X	X	X/X	X	X	X/X	X	X	X
8 - 9 AM	310	268	578	X	X	285	156	285	X	X	X	X	X/X	X	X	X	X/X	X	X	X/X	X	X	X	X
9 - 10 AM	329	286	615	X	X	253	149	253	X	X	X	X	X/X	X	X	X	X/X	X	X	X/X	X	X	X	X
10 - 11 AM	293	230	523	X		289	114	289	X	X	X	X	X/X	X	X	X	X/X	X	X	X/X	X	X	X	X
11 - Noon	353	314	667	X	X	318	168	318	X	X	X	X	X/X	X	X	X	X/X	X	X	X/X	X	X	X	X
12 - 1 PM	365	312	677	X	X	285	160	285	X	X	X	X	X/X	X	X	X	X/X	X	X	X/X	X	X	X	X
1 - 2 PM	358	353	711	X	X	266	131	266	X	X	X	X	X/X	X	X	X	X/X	X	X	X/X	X	X	X	X
2 - 3 PM	360	374	734	X	X	294	155	294	X	X	X	X	X/X	X	X	X	X/X	X	X	X/X	X	X	X	X
3 - 4 PM	338	396	734	X	X	363	192	363	X	X	X	X	X/X	X	X	X	X/X	X	X	X/X	X	X	X	X
4 - 5 PM	385	387	772	X	X	326	165	326	X	X	X	X	X/X	X	X	X	X/X	X	X	X/X	X	X	X	X
5 - 6 PM	305	295	600	X	X	266	134	266	X	X	X	X	X/X	X	X	X	X/X	X	X	X/X	X	X	X	X
6 - 7 PM	217	223	440	X		170	69	170	X	X	X		X/X	X		X	X	X/X	X	X	X/X	X	X	X
7 - 8 PM	132	161	293			185	58	185	X	X			X/-			X	X	X/X	X		X/-		X	X
8 - 9 PM	117	159	276			140	45	140	X	X					X		X/X			X/-			X	X
9 - 10 PM	101	90	191			72	18	72		X							X/-							X
10 - 11 PM	51	70	121			39	27	39																
11 - Midnight	41	41	82			30	5	30																

Summary	Signal Warrants ¹				Met	Req'd	Warrant Met?	Existing Signal Justification ²				Met 60%	Met 80%	Req'd	Justification Criteria Met?			
	Warrant 1							Existing Signal Justification: Reduced Warrant 1A				15	13	8	JUSTIFIED			
1A: 8-Hour (Minimum Vehicular Volume)							12	8	MET	Existing Signal Justification: Reduced Warrant 1B				12	12	8	JUSTIFIED	
1B: 8-Hour (Interruption of Continuous Traffic)							10	8	MET	Existing Signal Justification: Reduced Warrant 1C				15	12	8	JUSTIFIED	
1C: 8-Hour (Combination of 1A & 1B at 80%)							12	8	MET	All-Way Stop Warrants¹				Met	Req'd.	Warrant Met?		
Warrant 2: 4-Hour							12	4	MET	All-Way Stop: Crit. A (Signal Justified)				3	1	MET		
Warrant 3B: Peak Hour							11	1	MET	All-Way Stop: Crit. B (Crash History)				3	5	NO		
Warrant 7							All-Way Stop: Crit. C1 & C2 (Min Vols, Same Hrs)				12	8	MET		MET			
7B: Crash History							3	5	NO	All-Way Stop: Crit. C2 (Minor App. Delay)				32.8		30	MET	
7C: Condition A or Condition B (80%)							13	8	MET	All-Way Stop: Crit. D (80% of B, C1, & C2)				-		-	NO	

¹ Source: U.S. Dept. of Transportation FHWA Manual on Uniform Traffic Control Devices (2009 Edition)

² Source: MnDOT Traffic Engineering Manual, Chapter 9-5.02.05 "Traffic Control Signal Removal Justification Criteria"

TRAFFIC CONTROL WARRANTS ANALYSIS

2025 MnDOT District 3 ICE Reports, US 169 & MN 210 (W JCT)

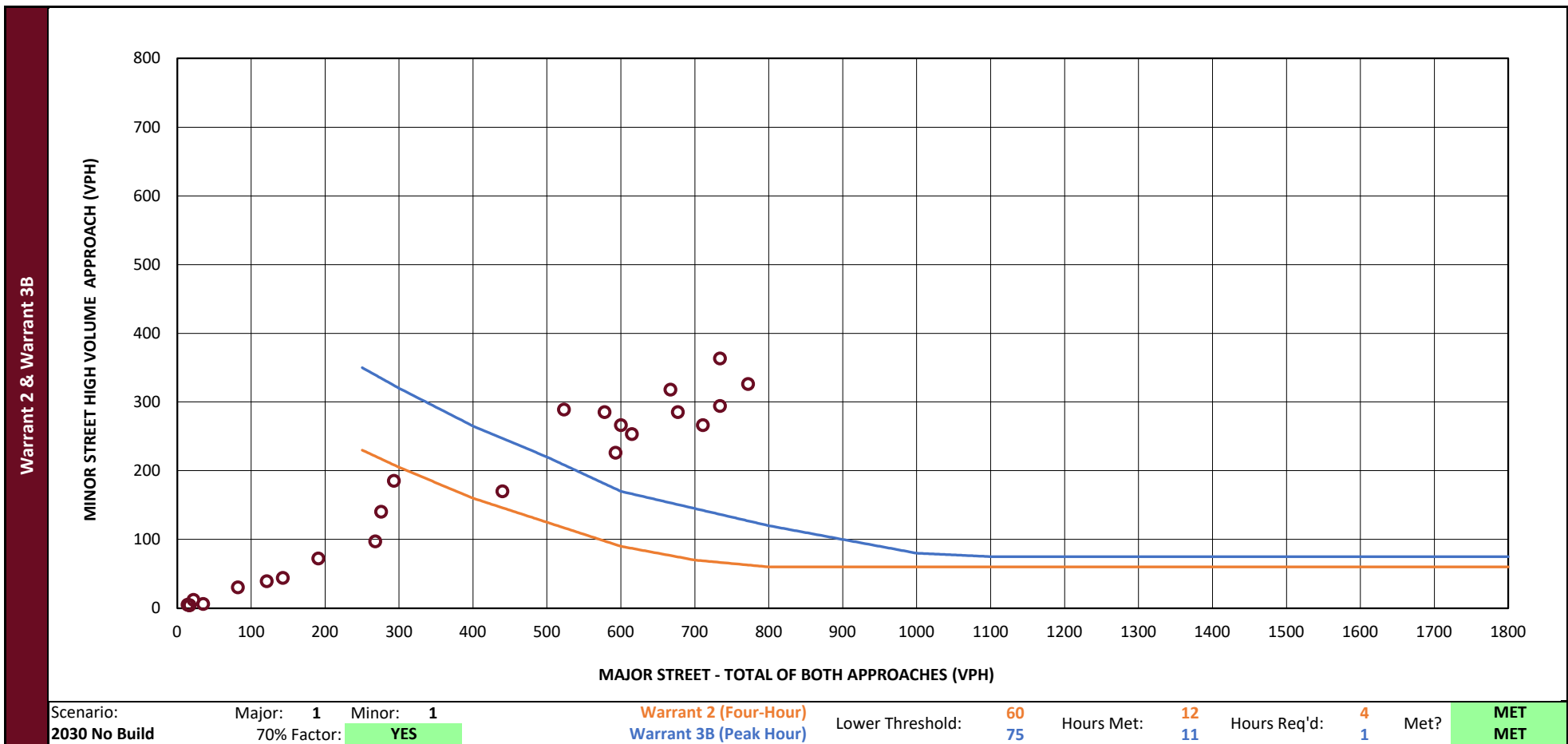

Source: U.S. Department of Transportation FHWA Manual on Uniform Traffic Control Devices (2009 Edition)

Warrant 2 (Four-Hour) Notes:

100%: 115 vph applies as the lower threshold volume for a minor-street approach with two or more lanes and 80 vph applies as the lower threshold volume for a minor-street approach with one lane.
 70%: 80 vph applies as the lower threshold volume for a minor-street approach with two or more lanes and 60 vph applies as the lower threshold volume for a minor-street approach with one lane.

Warrant 3B (Peak Hour) Notes:

100%: 150 vph applies as the lower threshold volume for a minor-street approach with two or more lanes and 100 vph applies as the lower threshold volume for a minor-street approach with one lane.
 70%: 100 vph applies as the lower threshold volume for a minor-street approach with two or more lanes and 75 vph applies as the lower threshold volume for a minor-street approach with one lane.

TRAFFIC CONTROL WARRANTS ANALYSIS

2025 MnDOT District 3 ICE Reports, US 169 & MN 210 (W JCT)

2050 No Build

Background	Project Data			Analysis	Volumes	Direction	Analysis Approach			Roadway			Speed	Lanes	RT %
	Project: 2025 MnDOT District 3 ICE Reports			Date: 7/18/2025	Scenario: 2050 No Build	WB	Major Approach 1			US 169 / MN 210			30	1	100%
	Intersection: US 169 & MN 210 (W JCT)					EB	Major Approach 3			MN 210			30	1	100%
	Population < 10,000?	YES	Exist. Traffic Control:	Analyst: CPH	Format: 15 MIN	NB	Minor Approach 2			US 169			30	1	100%
70% Factor Used:	YES	Signal			SB	Minor Approach 4			Minnesota Avenue N			30	1	100%	

Hour	Major Approaches					Minor Approaches					Traffic Signal Warrants					Existing Signal Justification						AWSC Warrants		
	Approach			Volumes Met		Approach			Volumes Met		8-Hour			4-Hr	Peak	60%			80%			C1	C2	80% of C1&C2
	WB	EB	Total	A	B	NB	SB	Max	A	B	1A	1B	1C (1A/1B)	2	3B	1A	1B	1C (1A/1B)	1A	1B	1C (1A/1B)	300	200	D
	1	3		350	525	2	4		105	53														
12 - 1 AM	16	16	32			21	11	21																
1 - 2 AM	8	15	23			10	4	10																
2 - 3 AM	18	7	25			8	2	8																
3 - 4 AM	9	15	24			6	7	7																
4 - 5 AM	26	19	45			11	8	11																
5 - 6 AM	82	90	172			54	30	54		X							X / -							
6 - 7 AM	159	170	329			118	51	118	X	X			X / -		X	X	X / X	X		X / -	X			X
7 - 8 AM	362	359	721	X	X	277	165	277	X	X	X	X	X / X	X	X	X	X / X	X	X	X / X	X	X	X	X
8 - 9 AM	376	328	704	X	X	350	189	350	X	X	X	X	X / X	X	X	X	X / X	X	X	X / X	X	X	X	X
9 - 10 AM	398	351	749	X	X	307	180	307	X	X	X	X	X / X	X	X	X	X / X	X	X	X / X	X	X	X	X
10 - 11 AM	359	281	640	X	X	353	139	353	X	X	X	X	X / X	X	X	X	X / X	X	X	X / X	X	X	X	X
11 - Noon	430	383	813	X	X	385	204	385	X	X	X	X	X / X	X	X	X	X / X	X	X	X / X	X	X	X	X
12 - 1 PM	443	383	826	X	X	346	192	346	X	X	X	X	X / X	X	X	X	X / X	X	X	X / X	X	X	X	X
1 - 2 PM	436	429	865	X	X	325	159	325	X	X	X	X	X / X	X	X	X	X / X	X	X	X / X	X	X	X	X
2 - 3 PM	437	456	893	X	X	358	187	358	X	X	X	X	X / X	X	X	X	X / X	X	X	X / X	X	X	X	X
3 - 4 PM	412	484	896	X	X	438	234	438	X	X	X	X	X / X	X	X	X	X / X	X	X	X / X	X	X	X	X
4 - 5 PM	466	471	937	X	X	398	201	398	X	X	X	X	X / X	X	X	X	X / X	X	X	X / X	X	X	X	X
5 - 6 PM	370	362	732	X	X	326	162	326	X	X	X	X	X / X	X	X	X	X / X	X	X	X / X	X	X	X	X
6 - 7 PM	263	270	533	X	X	206	84	206	X	X	X	X	X / X	X	X	X	X / X	X	X	X / X	X	X	X	X
7 - 8 PM	160	198	358	X		224	72	224	X	X	X		X / -	X		X	X	X / X	X		X / X	X	X	X
8 - 9 PM	145	196	341			171	57	171	X	X			X / -		X	X	X / X	X		X / X	X	X	X	X
9 - 10 PM	122	110	232			87	29	87		X					X		X / -			X / -				
10 - 11 PM	65	87	152			50	36	50																
11 - Midnight	53	53	106			39	10	39																

Summary	Signal Warrants ¹				Met	Req'd	Warrant Met?	Existing Signal Justification ²				Met 60%	Met 80%	Req'd	Justification Criteria Met?			
	Warrant 1							Existing Signal Justification: Reduced Warrant 1A				16	15	8	JUSTIFIED			
1A: 8-Hour (Minimum Vehicular Volume)							13	8	MET	Existing Signal Justification: Reduced Warrant 1B				15	12	8	JUSTIFIED	
1B: 8-Hour (Interruption of Continuous Traffic)							12	8	MET	Existing Signal Justification: Reduced Warrant 1C				15	14	8	JUSTIFIED	
1C: 8-Hour (Combination of 1A & 1B at 80%)							12	8	MET	All-Way Stop Warrants¹				Met	Req'd.	Warrant Met?		
Warrant 2: 4-Hour							13	4	MET	All-Way Stop: Crit. A (Signal Justified)				3	1	MET		
Warrant 3B: Peak Hour							12	1	MET	All-Way Stop: Crit. B (Crash History)				3	5	NO		
Warrant 7							All-Way Stop: Crit. C1 & C2 (Min Vols, Same Hrs)				14	8	MET		MET			
7B: Crash History							3	5	NO	All-Way Stop: Crit. C2 (Minor App. Delay)				88.2		30	MET	
7C: Condition A or Condition B (80%)							15	8	MET	All-Way Stop: Crit. D (80% of B, C1, & C2)				-		-	NO	

¹ Source: U.S. Dept. of Transportation FHWA Manual on Uniform Traffic Control Devices (2009 Edition)

² Source: MnDOT Traffic Engineering Manual, Chapter 9-5.02.05 "Traffic Control Signal Removal Justification Criteria"

TRAFFIC CONTROL WARRANTS ANALYSIS

2025 MnDOT District 3 ICE Reports, US 169 & MN 210 (W JCT)

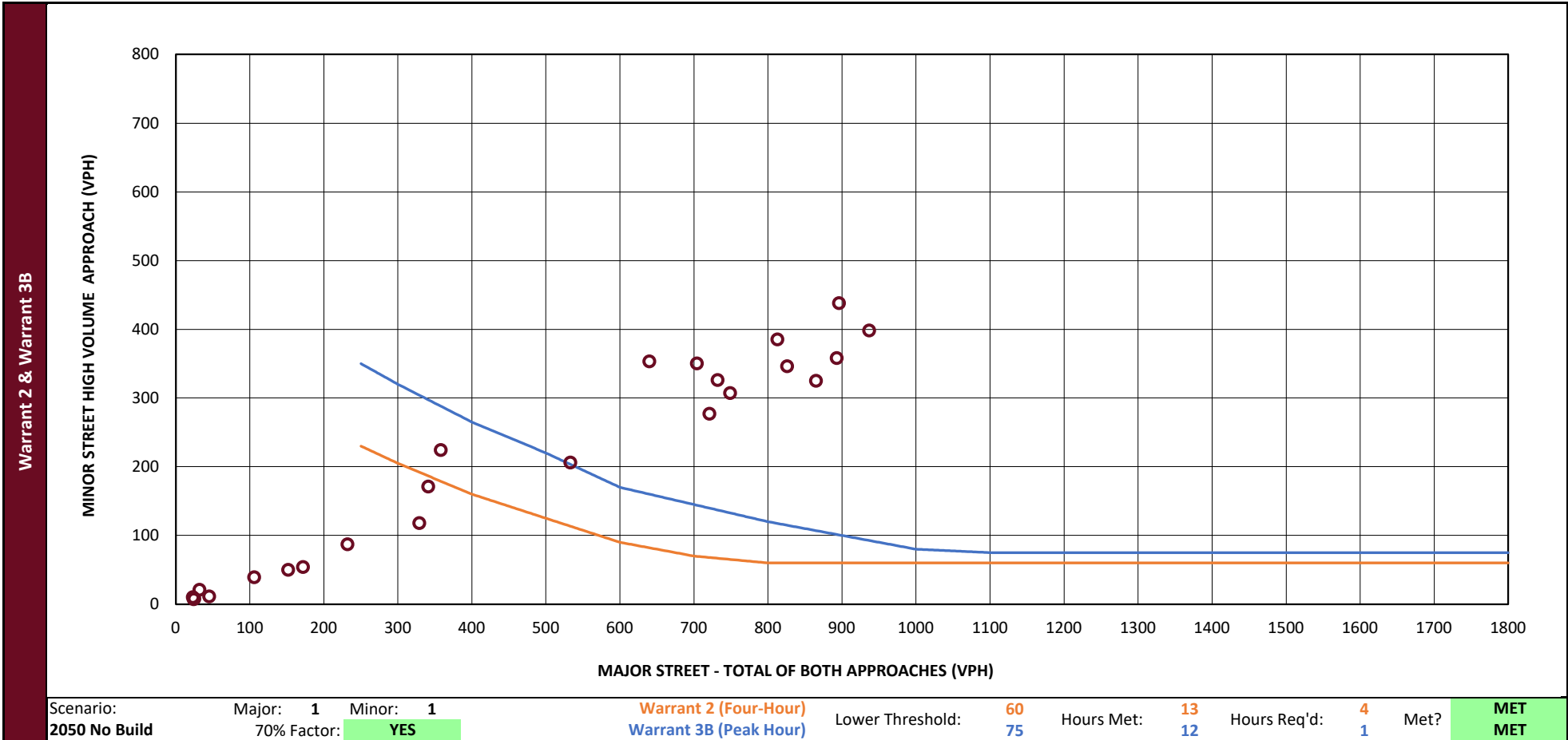

Source: U.S. Department of Transportation FHWA Manual on Uniform Traffic Control Devices (2009 Edition)

Warrant 2 (Four-Hour) Notes:

100%: 115 vph applies as the lower threshold volume for a minor-street approach with two or more lanes and 80 vph applies as the lower threshold volume for a minor-street approach with one lane.
 70%: 80 vph applies as the lower threshold volume for a minor-street approach with two or more lanes and 60 vph applies as the lower threshold volume for a minor-street approach with one lane.

Warrant 3B (Peak Hour) Notes:

100%: 150 vph applies as the lower threshold volume for a minor-street approach with two or more lanes and 100 vph applies as the lower threshold volume for a minor-street approach with one lane.
 70%: 100 vph applies as the lower threshold volume for a minor-street approach with two or more lanes and 75 vph applies as the lower threshold volume for a minor-street approach with one lane.

APPENDIX E: ROUNDABOUT CAPACITY ANALYSIS RESULTS

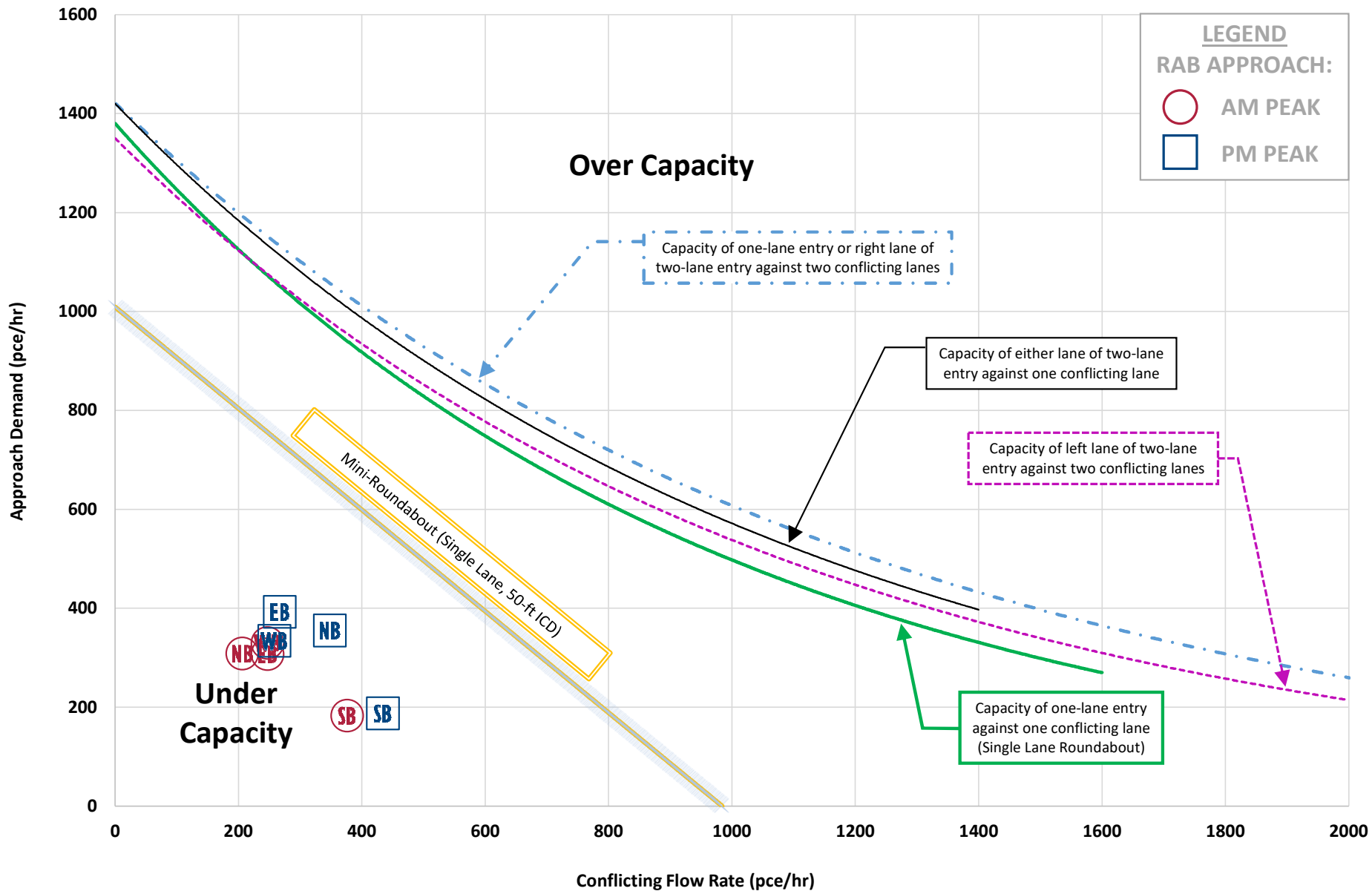

Year 2025 Weekday Traffic Volumes - Roundabout Capacity Analysis - US 169 & MN 210 (W JCT)

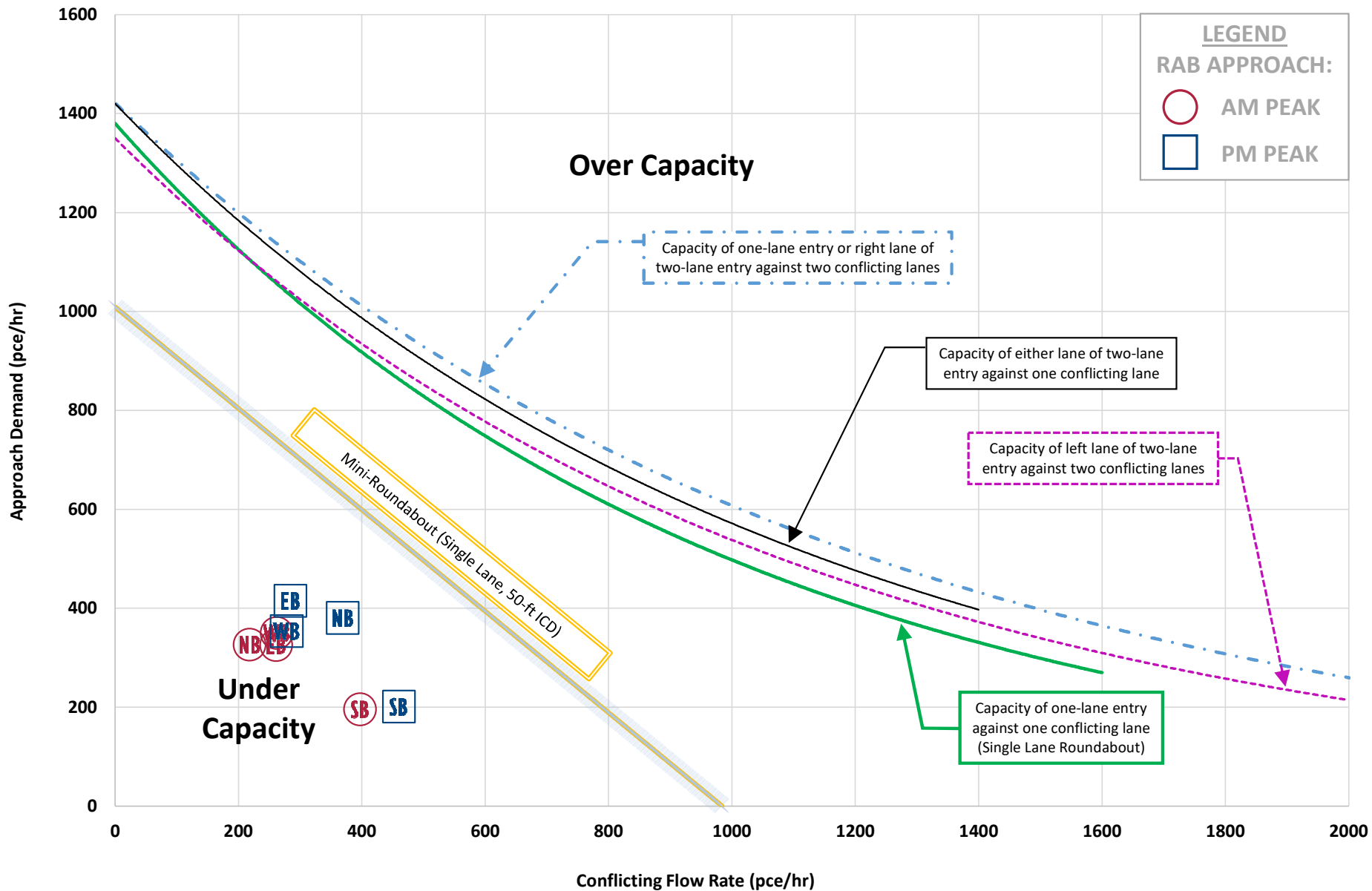

Year 2030 Weekday Traffic Volumes - Roundabout Capacity Analysis - US 169 & MN 210 (W JCT)

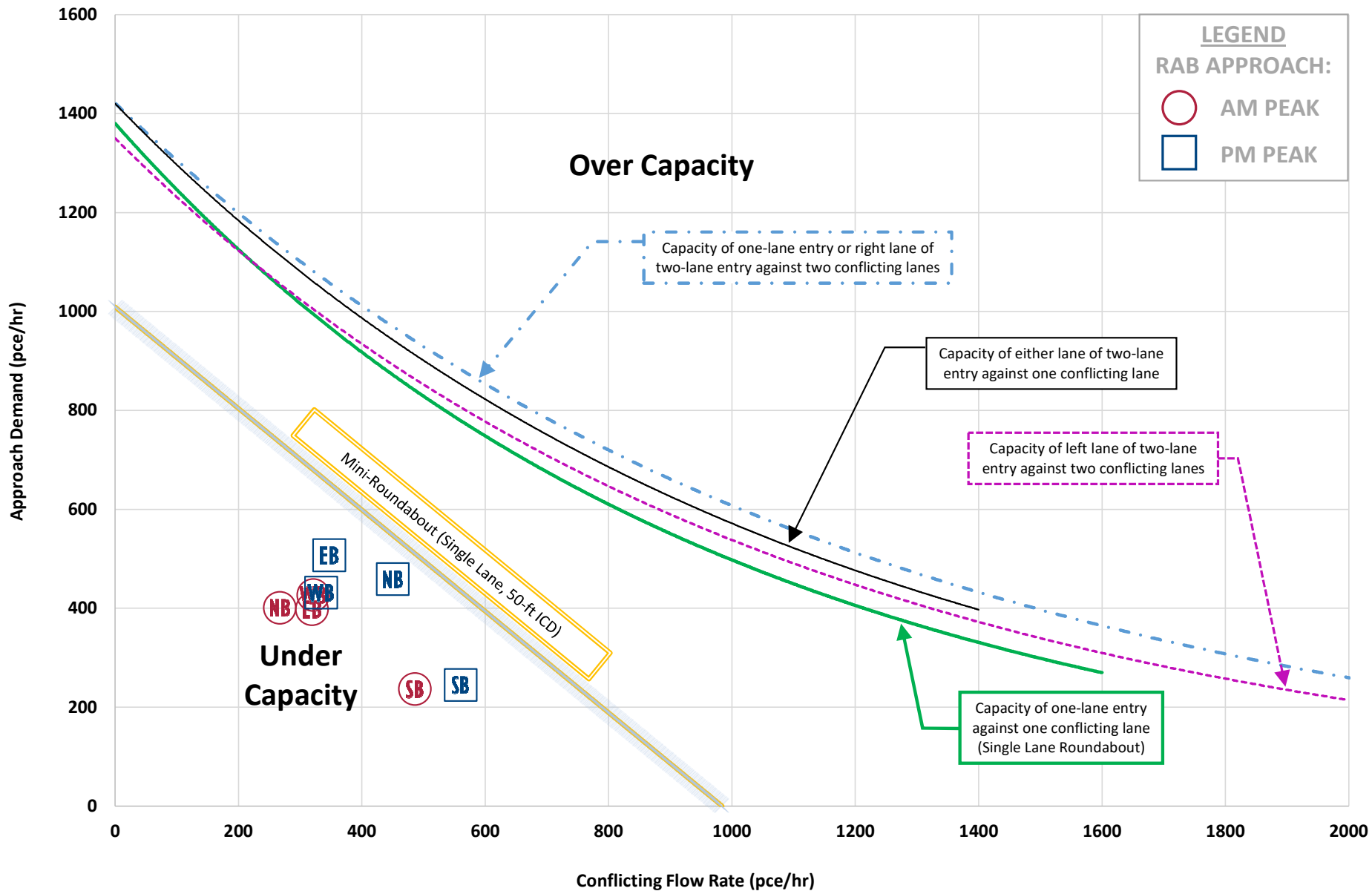

Year 2050 Weekday Traffic Volumes - Roundabout Capacity Analysis - US 169 & MN 210 (W JCT)

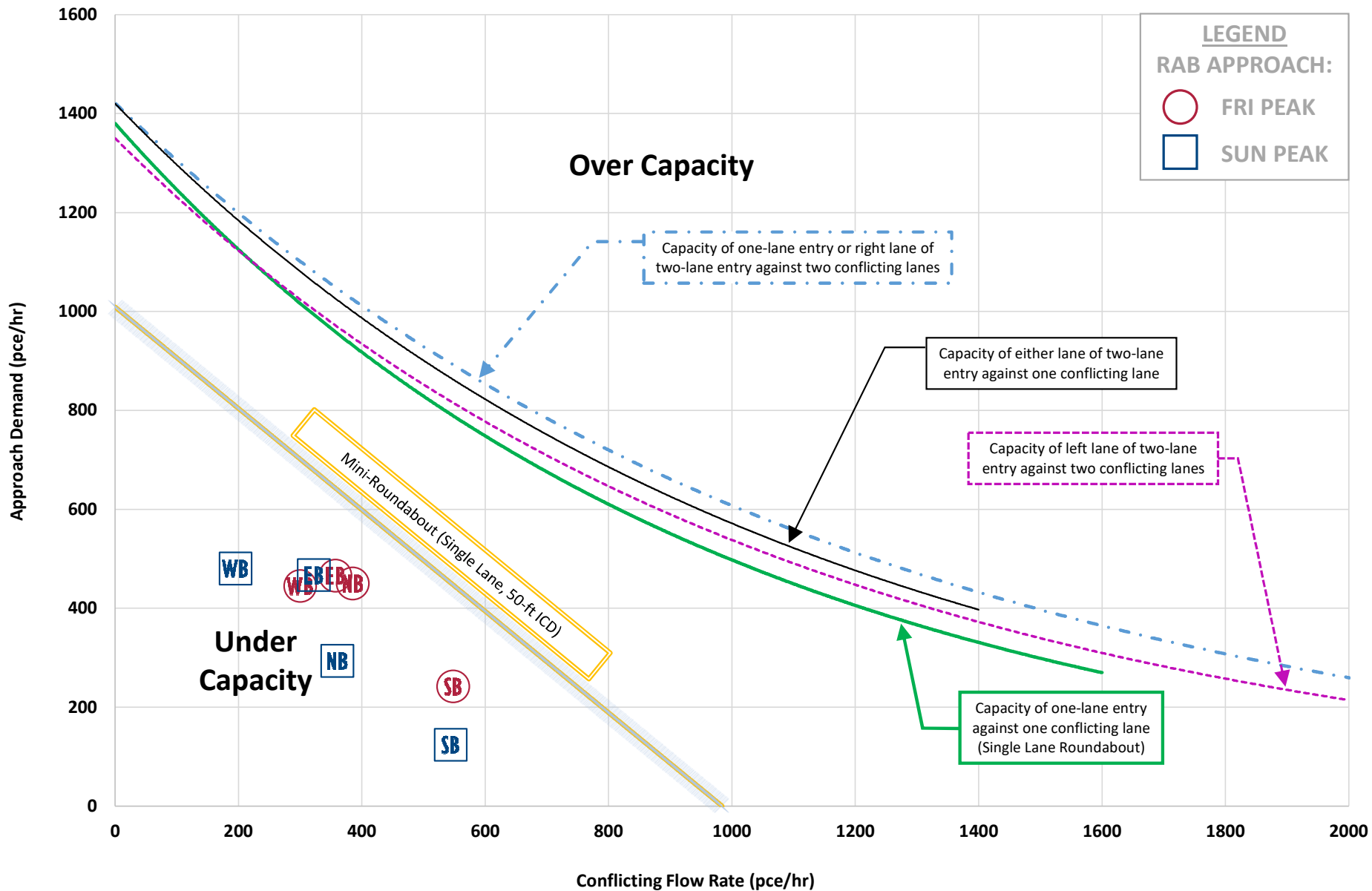

Year 2025 Weekend Traffic Volumes - Roundabout Capacity Analysis - US 169 & MN 210 (W JCT)

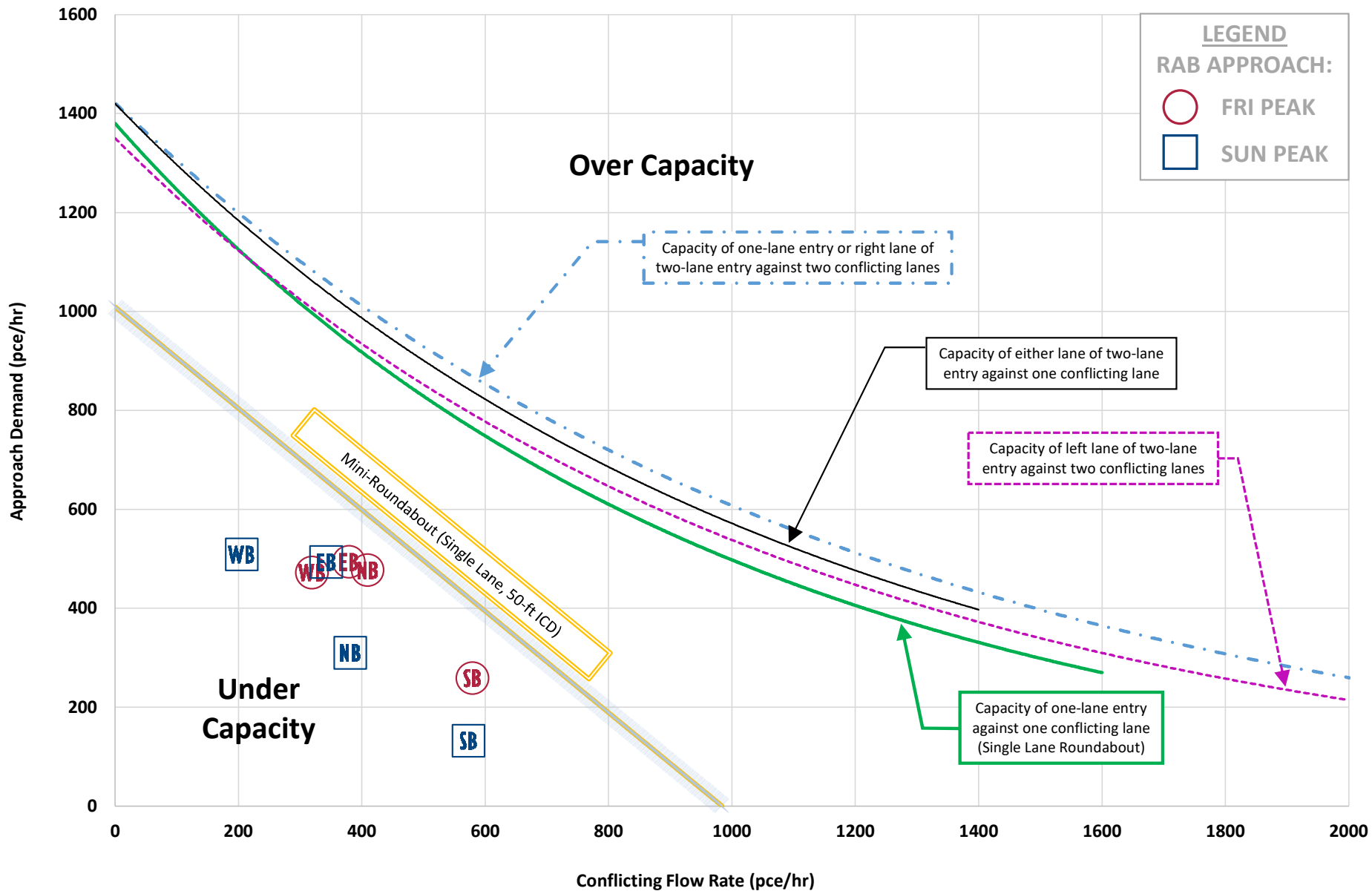

Year 2030 Weekend Traffic Volumes - Roundabout Capacity Analysis - US 169 & MN 210 (W JCT)

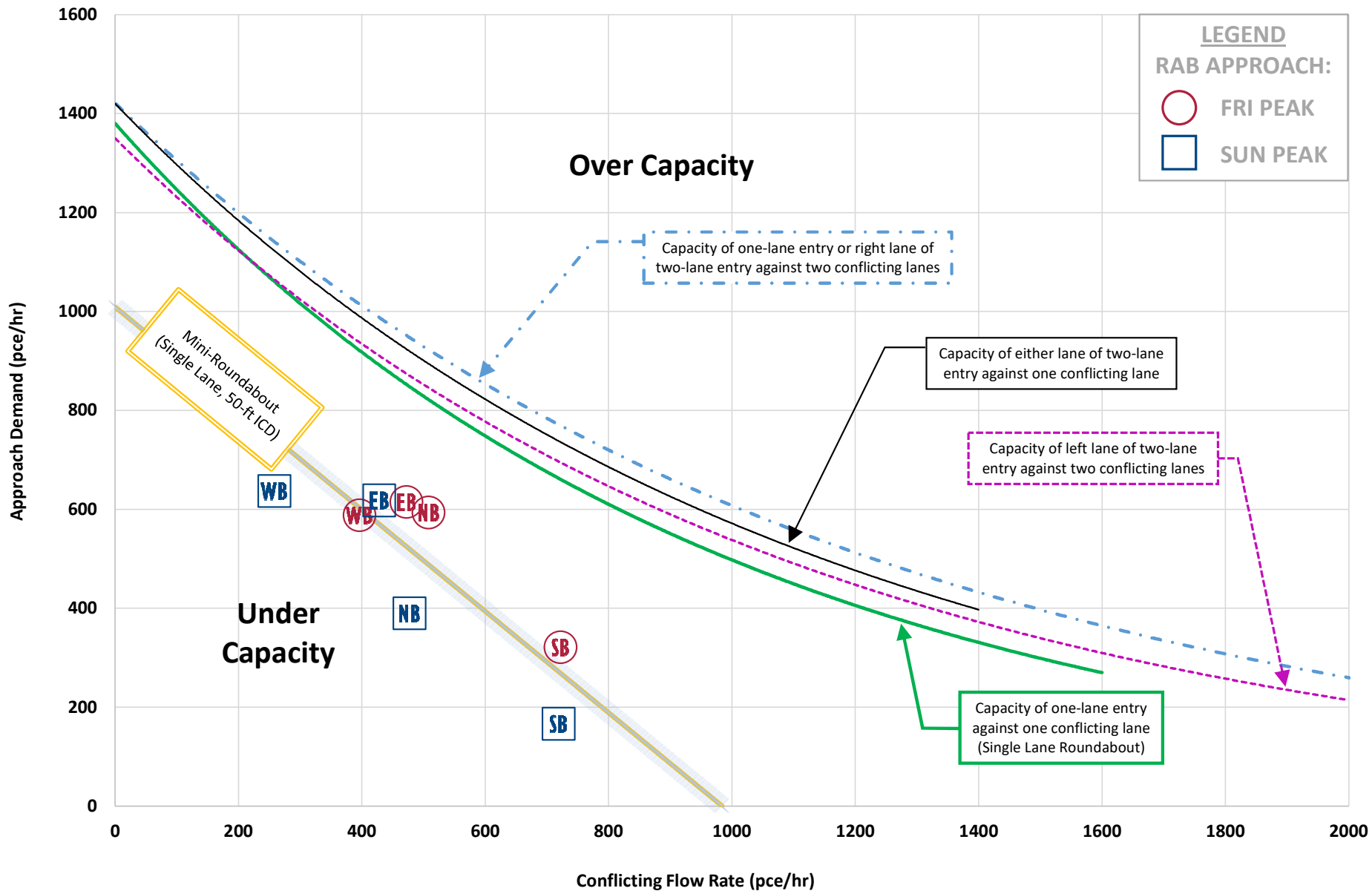

Year 2050 Weekend Traffic Volumes - Roundabout Capacity Analysis - US 169 & MN 210 (W JCT)

APPENDIX F: ALTERNATIVES MOE

Existing Year 2025 Conditions - AM Peak Hour

Intersection	MOE	Eastbound Approach			Westbound Approach			Northbound Approach			Southbound Approach			Intersection Total
		EBL	EBT	EBR	WBL	WBT	WBR	NBL	NBT	NBR	SBL	SBT	SBR	
US 169 & MN 210	Movement Delay (sec/veh)	24.3	25.5	16.6	28.7	27.4	20.9	31.1	31.2	18.5	22.8	22.7	9.8	24.8
	Total Delay (hr)	0.1	1.2	0.6	0.6	1.7	0.2	0.8	1.0	0.3	0.1	0.8	0.1	7.5
	Movement LOS	C	C	B	C	C	C	C	C	B	C	C	A	C
	Movement Volume	16	171	134	77	208	34	90	118	62	22	117	23	1072
	Movement 95th Queue (ft)	227	227	57	220	220	46	261	261	57	162	162	45	
	Storage Bay Distance (ft)	0	0	25	0	0	25	0	0	25	0	0	25	
	Approach Delay (sec/veh)	21.7			27.0			28.3			20.9			
Approach LOS	C			C			C			C				

Existing Year 2025 Conditions - PM Peak Hour

Intersection	MOE	Eastbound Approach			Westbound Approach			Northbound Approach			Southbound Approach			Intersection Total
		EBL	EBT	EBR	WBL	WBT	WBR	NBL	NBT	NBR	SBL	SBT	SBR	
US 169 & MN 210	Movement Delay (sec/veh)	27.1	29.3	20.0	27.9	27.8	22.7	33.9	33.4	20.4	25.0	22.4	8.4	26.7
	Total Delay (hr)	0.2	2.1	0.7	0.9	1.7	0.1	1.2	0.9	0.6	0.3	0.6	0.1	9.4
	Movement LOS	C	C	B	C	C	C	C	C	C	C	C	A	C
	Movement Volume	30	246	111	103	211	15	123	92	103	38	102	31	1205
	Movement 95th Queue (ft)	274	274	57	230	230	32	251	251	56	160	160	50	
	Storage Bay Distance (ft)	0	0	25	0	0	25	0	0	25	0	0	25	
	Approach Delay (sec/veh)	26.5			27.6			29.4			20.4			
Approach LOS	C			C			C			C				

Existing Year 2025 Conditions - FRI Peak Hour

Intersection	MOE	Eastbound Approach			Westbound Approach			Northbound Approach			Southbound Approach			Intersection Total
		EBL	EBT	EBR	WBL	WBT	WBR	NBL	NBT	NBR	SBL	SBT	SBR	
US 169 & MN 210	Movement Delay (sec/veh)	43.4	43.3	36.0	89.1	82.2	76.5	56.9	61.0	43.4	47.0	42.2	22.0	56.2
	Total Delay (hr)	0.3	3.6	1.4	3.6	6.4	0.7	2.2	2.4	2.2	0.7	1.9	0.1	25.5
	Movement LOS	D	D	D	F	F	E	E	E	D	D	D	C	E
	Movement Volume	27	287	136	137	259	32	132	138	176	55	157	24	1560
	Movement 95th Queue (ft)	469	469	54	793	793	47	578	578	58	282	282	45	
	Storage Bay Distance (ft)	0	0	25	0	0	25	0	0	25	0	0	25	
	Approach Delay (sec/veh)	41.1			84.0			52.8			41.3			
Approach LOS	D			F			D			D				

Existing Year 2025 Conditions - SUN Peak Hour

Intersection	MOE	Eastbound Approach			Westbound Approach			Northbound Approach			Southbound Approach			Intersection Total
		EBL	EBT	EBR	WBL	WBT	WBR	NBL	NBT	NBR	SBL	SBT	SBR	
US 169 & MN 210	Movement Delay (sec/veh)	32.5	29.8	21.5	44.1	42.6	39.1	37.7	36.9	23.7	32.4	28.6	8.8	33.8
	Total Delay (hr)	0.2	2.6	0.8	2.9	2.9	0.3	1.1	0.9	0.8	0.3	0.6	0.0	13.4
	Movement LOS	C	C	C	D	D	D	D	D	C	C	C	A	C
	Movement Volume	26	306	138	217	229	27	97	79	117	30	70	18	1354
	Movement 95th Queue (ft)	321	321	52	395	395	44	247	247	57	123	123	39	
	Storage Bay Distance (ft)	0	0	25	0	0	25	0	0	25	0	0	25	
	Approach Delay (sec/veh)	27.5			43.1			31.9			26.5			
Approach LOS	C			D			C			C				

2025 All-Way Stop - AM Peak Hour

Intersection	MOE	Eastbound Approach			Westbound Approach			Northbound Approach			Southbound Approach			Intersection Total
		EBL	EBT	EBR	WBL	WBT	WBR	NBL	NBT	NBR	SBL	SBT	SBR	
US 169 & MN 210	Movement Delay (sec/veh)	11.5	13.9	11.8	26.9	28.6	22.0	15.9	18.3	13.1	8.3	10.6	6.3	17.6
	Total Delay (hr)	0.1	0.7	0.5	0.6	1.7	0.2	0.4	0.6	0.2	0.1	0.3	0.0	5.4
	Movement LOS	B	B	B	D	D	C	C	C	B	A	B	A	C
	Movement Volume	16	171	134	77	208	34	90	118	62	22	117	22	1071
	Movement 95th Queue (ft)	142	142	58	196	196	58	142	142	58	91	91	51	
	Storage Bay Distance (ft)	0	0	25	0	0	25	0	0	25	0	0	25	
	Approach Delay (sec/veh)	12.9			27.5			16.3			9.7			
	Approach LOS	B			D			C			A			

2025 All-Way Stop - PM Peak Hour

Intersection	MOE	Eastbound Approach			Westbound Approach			Northbound Approach			Southbound Approach			Intersection Total
		EBL	EBT	EBR	WBL	WBT	WBR	NBL	NBT	NBR	SBL	SBT	SBR	
US 169 & MN 210	Movement Delay (sec/veh)	14.5	17.8	14.1	26.6	28.9	24.1	16.3	18.7	13.4	9.9	12.0	6.6	18.7
	Total Delay (hr)	0.1	1.2	0.5	0.8	1.8	0.1	0.6	0.5	0.4	0.1	0.3	0.1	6.5
	Movement LOS	B	C	B	D	D	C	C	C	B	A	B	A	C
	Movement Volume	30	246	111	103	211	15	123	92	103	38	102	31	1205
	Movement 95th Queue (ft)	153	153	56	186	186	46	143	143	55	98	98	53	
	Storage Bay Distance (ft)	0	0	25	0	0	25	0	0	25	0	0	25	
	Approach Delay (sec/veh)	16.5			28.0			16.1			10.6			
	Approach LOS	C			D			C			B			

2025 All-Way Stop - FRI Peak Hour

Intersection	MOE	Eastbound Approach			Westbound Approach			Northbound Approach			Southbound Approach			Intersection Total
		EBL	EBT	EBR	WBL	WBT	WBR	NBL	NBT	NBR	SBL	SBT	SBR	
US 169 & MN 210	Movement Delay (sec/veh)	54.0	63.3	49.8	96.6	94.7	93.1	49.7	59.9	45.4	20.4	21.2	10.7	60.7
	Total Delay (hr)	0.4	5.2	2.0	3.9	7.4	0.9	1.9	2.4	2.3	0.3	0.9	0.1	27.7
	Movement LOS	F	F	E	F	F	F	E	F	E	C	C	B	F
	Movement Volume	27	287	136	137	259	32	132	138	176	55	157	24	1560
	Movement 95th Queue (ft)	612	612	51	900	900	58	581	581	57	154	154	52	
	Storage Bay Distance (ft)	0	0	25	0	0	25	0	0	25	0	0	25	
	Approach Delay (sec/veh)	58.7			95.2			51.2			19.9			
	Approach LOS	F			F			F			C			

2025 All-Way Stop - SUN Peak Hour

Intersection	MOE	Eastbound Approach			Westbound Approach			Northbound Approach			Southbound Approach			Intersection Total
		EBL	EBT	EBR	WBL	WBT	WBR	NBL	NBT	NBR	SBL	SBT	SBR	
US 169 & MN 210	Movement Delay (sec/veh)	20.3	22.5	18.9	40.3	40.9	37.0	15.1	16.5	14.0	9.0	10.9	6.0	25.6
	Total Delay (hr)	0.2	2.0	0.8	2.6	2.8	0.3	0.4	0.4	0.5	0.1	0.2	0.0	10.3
	Movement LOS	C	C	C	E	E	E	C	C	B	A	B	A	D
	Movement Volume	26	306	138	217	229	27	97	79	117	30	70	18	1354
	Movement 95th Queue (ft)	212	212	50	307	307	54	123	123	55	62	62	41	
	Storage Bay Distance (ft)	0	0	25	0	0	25	0	0	25	0	0	25	
	Approach Delay (sec/veh)	21.3			40.4			15.0			9.7			
	Approach LOS	C			E			C			A			

2025 Modified Signal Timing - AM Peak Hour

Intersection	MOE	Eastbound Approach			Westbound Approach			Northbound Approach			Southbound Approach			Intersection Total
		EBL	EBT	EBR	WBL	WBT	WBR	NBL	NBT	NBR	SBL	SBT	SBR	
US 169 & MN 210	Movement Delay (sec/veh)	15.3	15.6	10.4	29.6	27.7	20.8	24.7	24.4	16.0	16.7	16.4	8.1	20.2
	Total Delay (hr)	0.1	0.8	0.4	0.7	1.7	0.2	0.6	0.8	0.3	0.1	0.5	0.1	6.3
	Movement LOS	B	B	B	C	C	C	C	C	B	B	B	A	C
	Movement Volume	16	171	134	77	208	34	90	118	62	22	117	23	1072
	Movement 95th Queue (ft)	164	164	61	237	237	47	219	219	57	140	140	45	
	Storage Bay Distance (ft)	0	0	25	0	0	25	0	0	25	0	0	25	
	Approach Delay (sec/veh)	13.4			27.4			22.6			15.3			
Approach LOS	B			C			C			B				

2025 Modified Signal Timing - PM Peak Hour

Intersection	MOE	Eastbound Approach			Westbound Approach			Northbound Approach			Southbound Approach			Intersection Total
		EBL	EBT	EBR	WBL	WBT	WBR	NBL	NBT	NBR	SBL	SBT	SBR	
US 169 & MN 210	Movement Delay (sec/veh)	30.3	32.7	22.3	30.1	30.3	23.8	37.2	37.6	24.8	28.7	26.9	11.5	29.9
	Total Delay (hr)	0.3	2.3	0.7	0.9	1.9	0.1	1.3	1.0	0.7	0.3	0.8	0.1	10.4
	Movement LOS	C	C	C	C	C	C	D	D	C	C	C	B	C
	Movement Volume	30	246	111	103	211	15	123	92	103	38	102	31	1205
	Movement 95th Queue (ft)	306	306	55	239	239	31	284	284	57	181	181	49	
	Storage Bay Distance (ft)	0	0	25	0	0	25	0	0	25	0	0	25	
	Approach Delay (sec/veh)	29.5			29.9			33.3			24.5			
Approach LOS	C			C			C			C				

2025 Modified Signal Timing - FRI Peak Hour

Intersection	MOE	Eastbound Approach			Westbound Approach			Northbound Approach			Southbound Approach			Intersection Total
		EBL	EBT	EBR	WBL	WBT	WBR	NBL	NBT	NBR	SBL	SBT	SBR	
US 169 & MN 210	Movement Delay (sec/veh)	48.9	54.6	43.0	79.3	77.9	67.8	61.4	65.5	48.6	62.0	52.4	28.7	60.3
	Total Delay (hr)	0.4	4.5	1.7	3.3	6.0	0.7	2.4	2.6	2.5	0.9	2.3	0.2	27.5
	Movement LOS	D	D	D	E	E	E	E	E	D	E	D	C	E
	Movement Volume	27	287	136	137	259	32	132	138	176	55	157	24	1560
	Movement 95th Queue (ft)	528	528	54	752	752	46	576	576	59	339	339	45	
	Storage Bay Distance (ft)	0	0	25	0	0	25	0	0	25	0	0	25	
	Approach Delay (sec/veh)	50.8			77.6			57.6			52.2			
Approach LOS	D			E			E			D				

2025 Modified Signal Timing - SUN Peak Hour

Intersection	MOE	Eastbound Approach			Westbound Approach			Northbound Approach			Southbound Approach			Intersection Total
		EBL	EBT	EBR	WBL	WBT	WBR	NBL	NBT	NBR	SBL	SBT	SBR	
US 169 & MN 210	Movement Delay (sec/veh)	32.0	36.0	26.9	41.9	41.5	38.9	38.9	40.8	24.8	31.0	28.5	9.7	35.6
	Total Delay (hr)	0.2	3.2	1.1	2.7	2.8	0.3	1.1	1.0	0.8	0.3	0.6	0.0	14.1
	Movement LOS	C	D	C	D	D	D	D	D	C	C	C	A	D
	Movement Volume	26	306	138	217	229	27	97	79	117	30	70	18	1354
	Movement 95th Queue (ft)	375	375	49	385	385	43	259	259	56	126	126	41	
	Storage Bay Distance (ft)	0	0	25	0	0	25	0	0	25	0	0	25	
	Approach Delay (sec/veh)	33.1			41.5			33.8			26.3			
Approach LOS	C			D			C			C				

2025 Modified Signal Timing + Right-Turn Lanes - AM Peak Hour

Intersection	MOE	Eastbound Approach			Westbound Approach			Northbound Approach			Southbound Approach			Intersection Total
		EBL	EBT	EBR	WBL	WBT	WBR	NBL	NBT	NBR	SBL	SBT	SBR	
US 169 & MN 210	Movement Delay (sec/veh)	13.1	14.2	8.0	26.0	25.7	16.4	21.6	22.6	10.5	16.0	14.5	5.9	17.8
	Total Delay (hr)	0.1	0.7	0.3	0.6	1.6	0.2	0.6	0.8	0.2	0.1	0.5	0.0	5.7
	Movement LOS	B	B	A	C	C	B	C	C	B	B	B	A	B
	Movement Volume	16	171	134	77	208	34	90	118	62	22	117	23	1072
	Movement 95th Queue (ft)	121	121	89	199	199	81	182	182	98	121	121	49	
	Storage Bay Distance (ft)	0	0	75	0	0	75	0	0	75	0	0	75	
	Approach Delay (sec/veh)	11.6			24.8			19.5			13.5			
Approach LOS	B			C			B			B				

2025 Modified Signal Timing + Right-Turn Lanes - PM Peak Hour

Intersection	MOE	Eastbound Approach			Westbound Approach			Northbound Approach			Southbound Approach			Intersection Total
		EBL	EBT	EBR	WBL	WBT	WBR	NBL	NBT	NBR	SBL	SBT	SBR	
US 169 & MN 210	Movement Delay (sec/veh)	27.8	30.8	14.5	26.0	26.3	17.4	30.6	32.7	14.1	24.7	22.4	6.2	25.0
	Total Delay (hr)	0.2	2.2	0.5	0.8	1.6	0.1	1.1	0.9	0.4	0.3	0.6	0.1	8.8
	Movement LOS	C	C	B	C	C	B	C	C	B	C	C	A	C
	Movement Volume	30	246	111	103	211	15	123	92	103	38	102	31	1205
	Movement 95th Queue (ft)	264	264	122	210	210	50	247	247	121	143	143	67	
	Storage Bay Distance (ft)	0	0	75	0	0	75	0	0	75	0	0	75	
	Approach Delay (sec/veh)	25.9			25.8			25.9			20.0			
Approach LOS	C			C			C			B				

2025 Modified Signal Timing + Right-Turn Lanes - FRI Peak Hour

Intersection	MOE	Eastbound Approach			Westbound Approach			Northbound Approach			Southbound Approach			Intersection Total
		EBL	EBT	EBR	WBL	WBT	WBR	NBL	NBT	NBR	SBL	SBT	SBR	
US 169 & MN 210	Movement Delay (sec/veh)	42.0	42.2	22.8	45.2	43.9	31.2	45.0	44.1	22.3	34.3	32.9	10.6	37.3
	Total Delay (hr)	0.3	3.5	0.9	1.9	3.4	0.3	1.7	1.8	1.1	0.5	1.4	0.1	16.9
	Movement LOS	D	D	C	D	D	C	D	D	C	C	C	B	D
	Movement Volume	27	287	136	137	259	32	132	138	176	55	157	24	1560
	Movement 95th Queue (ft)	419	419	128	394	394	79	394	394	132	245	245	72	
	Storage Bay Distance (ft)	0	0	75	0	0	75	0	0	75	0	0	75	
	Approach Delay (sec/veh)	36.3			43.4			35.8			31.0			
Approach LOS	D			D			D			C				

2025 Modified Signal Timing + Right-Turn Lanes - SUN Peak Hour

Intersection	MOE	Eastbound Approach			Westbound Approach			Northbound Approach			Southbound Approach			Intersection Total
		EBL	EBT	EBR	WBL	WBT	WBR	NBL	NBT	NBR	SBL	SBT	SBR	
US 169 & MN 210	Movement Delay (sec/veh)	30.8	29.7	15.5	31.7	30.8	23.8	32.7	33.9	14.0	30.1	26.0	5.0	27.3
	Total Delay (hr)	0.2	2.6	0.6	2.1	2.1	0.2	0.9	0.8	0.5	0.3	0.5	0.0	10.8
	Movement LOS	C	C	B	C	C	C	C	C	B	C	C	A	C
	Movement Volume	26	306	138	217	229	27	97	79	117	30	70	18	1354
	Movement 95th Queue (ft)	311	311	127	278	278	68	183	183	119	114	114	38	
	Storage Bay Distance (ft)	0	0	75	0	0	75	0	0	75	0	0	75	
	Approach Delay (sec/veh)	25.6			30.8			25.6			23.8			
Approach LOS	C			C			C			C				

2025 Mini Roundabout - Weekday Peak Hours

Traffic Control	Intersection	Approach or Movement	AM Peak Hour										PM Peak Hour									
			EB		WB		NB		SB		Intersection		EB		WB		NB		SB		Intersection	
			Delay (s/v)	LOS	Delay (s/v)	LOS	Delay (s/v)	LOS	Delay (s/v)	LOS	Delay (s/v)	LOS	Delay (s/v)	LOS	Delay (s/v)	LOS	Delay (s/v)	LOS	Delay (s/v)	LOS	Delay (s/v)	LOS
Roundabout	US 169 & MN 210	Approach	2.5	A	2.3	A	1.9	A	1.8	A	2.1	A	3.4	A	3.2	A	2.3	A	2.6	A	2.9	A
		Left	2.5	A	2.5	A	1.6	A	1.8	A			3.3	A	3.5	A	2.5	A	2.7	A		
		Through	2.6	A	2.3	A	1.9	A	1.8	A			3.4	A	3.2	A	2.3	A	2.5	A		
		Right	2.3	A	2.4	A	1.9	A	1.8	A			3.3	A	3.1	A	2.1	A	3.0	A		

2025 Mini Roundabout - Weekend Peak Hours

Traffic Control	Intersection	Approach or Movement	FRI Peak Hour										SUN Peak Hour									
			EB		WB		NB		SB		Intersection		EB		WB		NB		SB		Intersection	
			Delay (s/v)	LOS	Delay (s/v)	LOS	Delay (s/v)	LOS	Delay (s/v)	LOS	Delay (s/v)	LOS	Delay (s/v)	LOS	Delay (s/v)	LOS	Delay (s/v)	LOS	Delay (s/v)	LOS	Delay (s/v)	LOS
Roundabout	US 169 & MN 210	Approach	5.0	A	3.9	A	3.0	A	3.5	A	4.0	A	3.6	A	2.7	A	1.9	A	3.1	A	2.9	A
		Left	5.0	A	3.8	A	3.1	A	3.5	A			3.5	A	3.4	A	2.0	A	3.0	A		
		Through	5.0	A	3.9	A	3.0	A	3.5	A			3.4	A	2.6	A	1.9	A	3.1	A		
		Right	5.0	A	3.9	A	2.7	A	3.5	A			3.7	A	2.8	A	1.8	A	3.2	A		

2025 Truck Route - AM Peak Hour

Intersection	MOE	Eastbound Approach			Westbound Approach			Northbound Approach			Southbound Approach			Intersection Total
		EBL	EBT	EBR	WBL	WBT	WBR	NBL	NBT	NBR	SBL	SBT	SBR	
US 169 & MN 210	Movement Delay (sec/veh)	23.2	23.7	13.2	26.0	23.2	20.5	27.1	25.6	15.0	19.7	19.1	7.4	21.4
	Total Delay (hr)	0.1	1.0	0.5	0.5	1.3	0.2	0.7	0.8	0.2	0.1	0.6	0.0	6.0
	Movement LOS	C	C	B	C	C	C	C	C	B	B	B	A	C
	Movement Volume	12	153	131	73	189	33	87	111	58	20	104	21	992
	Movement 95th Queue (ft)	174	174	51	160	160	44	185	185	53	103	103	40	
	Storage Bay Distance (ft)	0	0	25	0	0	25	0	0	25	0	0	25	
	Approach Delay (sec/veh)	19.0			23.6			23.7			17.5			
Approach LOS	B			C			C			B				

2025 Truck Route - PM Peak Hour

Intersection	MOE	Eastbound Approach			Westbound Approach			Northbound Approach			Southbound Approach			Intersection Total
		EBL	EBT	EBR	WBL	WBT	WBR	NBL	NBT	NBR	SBL	SBT	SBR	
US 169 & MN 210	Movement Delay (sec/veh)	27.5	28.9	17.9	29.5	28.1	22.8	32.4	30.0	20.6	23.2	22.8	8.9	26.2
	Total Delay (hr)	0.2	2.0	0.6	0.9	1.7	0.1	1.2	0.9	0.6	0.2	0.7	0.1	9.2
	Movement LOS	C	C	B	C	C	C	C	C	C	C	C	A	C
	Movement Volume	26	242	115	102	204	18	128	102	102	38	111	32	1220
	Movement 95th Queue (ft)	248	248	50	214	214	37	236	236	51	146	146	49	
	Storage Bay Distance (ft)	0	0	25	0	0	25	0	0	25	0	0	25	
	Approach Delay (sec/veh)	25.5			28.2			28.0			20.4			
Approach LOS	C			C			C			C				

2025 Truck Route - FRI Peak Hour

Intersection	MOE	Eastbound Approach			Westbound Approach			Northbound Approach			Southbound Approach			Intersection Total
		EBL	EBT	EBR	WBL	WBT	WBR	NBL	NBT	NBR	SBL	SBT	SBR	
US 169 & MN 210	Movement Delay (sec/veh)	39.6	37.5	26.3	59.5	55.0	49.4	43.2	43.4	32.7	38.0	37.2	18.0	41.8
	Total Delay (hr)	0.2	2.9	1.0	2.3	4.2	0.5	1.6	1.6	1.6	0.5	1.6	0.1	18.1
	Movement LOS	D	D	C	E	D	D	D	D	C	D	D	B	D
	Movement Volume	21	273	135	134	257	33	127	126	171	46	151	26	1500
	Movement 95th Queue (ft)	379	379	48	471	471	45	379	379	48	258	258	43	
	Storage Bay Distance (ft)	0	0	25	0	0	25	0	0	25	0	0	25	
	Approach Delay (sec/veh)	34.1			56.0			39.0			35.1			
Approach LOS	C			E			D			D				

2025 Truck Route - SUN Peak Hour

Intersection	MOE	Eastbound Approach			Westbound Approach			Northbound Approach			Southbound Approach			Intersection Total
		EBL	EBT	EBR	WBL	WBT	WBR	NBL	NBT	NBR	SBL	SBT	SBR	
US 169 & MN 210	Movement Delay (sec/veh)	30.8	27.0	18.8	43.7	40.1	39.9	35.4	34.0	22.1	28.8	28.4	9.3	31.9
	Total Delay (hr)	0.2	2.2	0.7	2.7	2.7	0.4	1.0	0.8	0.8	0.2	0.6	0.1	12.4
	Movement LOS	C	C	B	D	D	D	D	C	C	C	C	A	C
	Movement Volume	21	286	133	214	226	31	97	77	120	29	79	21	1334
	Movement 95th Queue (ft)	287	287	51	368	368	46	238	238	52	126	126	42	
	Storage Bay Distance (ft)	0	0	25	0	0	25	0	0	25	0	0	25	
	Approach Delay (sec/veh)	24.7			41.7			29.6			25.4			
Approach LOS	C			D			C			C				

Forecast Year 2030 All-Way Stop - AM Peak Hour

Intersection	MOE	Eastbound Approach			Westbound Approach			Northbound Approach			Southbound Approach			Intersection Total
		EBL	EBT	EBR	WBL	WBT	WBR	NBL	NBT	NBR	SBL	SBT	SBR	
US 169 & MN 210	Movement Delay (sec/veh)	12.2	14.8	12.5	29.0	32.2	24.7	15.7	19.5	12.8	9.1	11.2	7.0	19.2
	Total Delay (hr)	0.1	0.7	0.5	0.7	2.2	0.3	0.4	0.7	0.2	0.1	0.4	0.0	6.3
	Movement LOS	B	B	B	D	D	C	C	C	B	A	B	A	C
	Movement Volume	20	179	134	81	229	40	91	123	63	24	126	23	1133
	Movement 95th Queue (ft)	147	147	56	228	228	60	152	152	58	95	95	50	
	Storage Bay Distance (ft)	0	0	25	0	0	25	0	0	25	0	0	25	
	Approach Delay (sec/veh)	13.7			30.6			16.7			10.4			
	Approach LOS	B			D			C			B			

Forecast Year 2030 All-Way Stop - PM Peak Hour

Intersection	MOE	Eastbound Approach			Westbound Approach			Northbound Approach			Southbound Approach			Intersection Total
		EBL	EBT	EBR	WBL	WBT	WBR	NBL	NBT	NBR	SBL	SBT	SBR	
US 169 & MN 210	Movement Delay (sec/veh)	16.2	20.7	15.8	28.7	31.2	25.0	17.9	19.5	15.2	10.1	12.5	7.5	20.4
	Total Delay (hr)	0.1	1.5	0.5	0.9	2.0	0.1	0.7	0.6	0.5	0.1	0.4	0.1	7.5
	Movement LOS	C	C	C	D	D	C	C	C	C	B	B	A	C
	Movement Volume	31	252	117	102	222	18	135	105	109	43	108	36	1278
	Movement 95th Queue (ft)	183	183	52	217	217	47	150	150	56	97	97	58	
	Storage Bay Distance (ft)	0	0	25	0	0	25	0	0	25	0	0	25	
	Approach Delay (sec/veh)	18.9			30.1			17.5			11.0			
	Approach LOS	C			D			C			B			

Forecast Year 2030 All-Way Stop - FRI Peak Hour

Intersection	MOE	Eastbound Approach			Westbound Approach			Northbound Approach			Southbound Approach			Intersection Total
		EBL	EBT	EBR	WBL	WBT	WBR	NBL	NBT	NBR	SBL	SBT	SBR	
US 169 & MN 210	Movement Delay (sec/veh)	109.7	99.8	77.0	167.0	165.0	157.0	56.1	67.2	54.3	26.1	26.3	16.2	92.9
	Total Delay (hr)	0.8	8.7	3.1	7.6	13.7	1.7	2.3	2.7	2.9	0.4	1.3	0.1	45.3
	Movement LOS	F	F	F	F	F	F	F	F	F	D	D	C	F
	Movement Volume	25	304	141	151	272	36	140	141	185	57	171	29	1652
	Movement 95th Queue (ft)	949	949	53	1299	1299	58	598	598	56	200	200	54	
	Storage Bay Distance (ft)	0	0	25	0	0	25	0	0	25	0	0	25	
	Approach Delay (sec/veh)	93.5			165.0			58.7			25.1			
	Approach LOS	F			F			F			D			

Forecast Year 2030 All-Way Stop - SUN Peak Hour

Intersection	MOE	Eastbound Approach			Westbound Approach			Northbound Approach			Southbound Approach			Intersection Total
		EBL	EBT	EBR	WBL	WBT	WBR	NBL	NBT	NBR	SBL	SBT	SBR	
US 169 & MN 210	Movement Delay (sec/veh)	22.0	25.9	22.2	52.2	52.2	50.1	16.6	17.4	14.3	9.8	12.2	6.6	30.8
	Total Delay (hr)	0.2	2.4	0.9	3.5	3.8	0.4	0.5	0.4	0.5	0.1	0.3	0.0	13.0
	Movement LOS	C	D	C	F	F	F	C	C	B	A	B	A	D
	Movement Volume	27	319	145	224	241	29	102	81	128	32	79	25	1432
	Movement 95th Queue (ft)	260	260	52	423	423	55	132	132	55	75	75	46	
	Storage Bay Distance (ft)	0	0	25	0	0	25	0	0	25	0	0	25	
	Approach Delay (sec/veh)	24.6			52.1			15.9			10.6			
	Approach LOS	C			F			C			B			

Forecast Year 2030 Modified Signal Timing - AM Peak Hour

Intersection	MOE	Eastbound Approach			Westbound Approach			Northbound Approach			Southbound Approach			Intersection Total
		EBL	EBT	EBR	WBL	WBT	WBR	NBL	NBT	NBR	SBL	SBT	SBR	
US 169 & MN 210	Movement Delay (sec/veh)	27.9	30.7	19.5	31.3	30.0	23.4	34.7	35.7	20.6	24.9	26.0	10.5	28.2
	Total Delay (hr)	0.2	1.6	0.8	0.7	2.0	0.3	0.9	1.2	0.4	0.2	0.9	0.1	9.3
	Movement LOS	C	C	B	C	C	C	C	D	C	C	C	B	C
	Movement Volume	20	179	134	81	229	40	91	123	63	24	126	23	1133
	Movement 95th Queue (ft)	262	262	56	252	252	48	288	288	58	180	180	45	
	Storage Bay Distance (ft)	0	0	25	0	0	25	0	0	25	0	0	25	
	Approach Delay (sec/veh)	26.0			29.5			31.9			23.8			
Approach LOS	C			C			C			C				

Forecast Year 2030 Modified Signal Timing - PM Peak Hour

Intersection	MOE	Eastbound Approach			Westbound Approach			Northbound Approach			Southbound Approach			Intersection Total
		EBL	EBT	EBR	WBL	WBT	WBR	NBL	NBT	NBR	SBL	SBT	SBR	
US 169 & MN 210	Movement Delay (sec/veh)	31.3	38.1	27.0	32.3	31.7	24.9	38.0	38.7	27.3	29.3	28.6	10.0	32.4
	Total Delay (hr)	0.3	2.8	0.9	1.0	2.1	0.1	1.5	1.2	0.9	0.4	0.9	0.1	12.2
	Movement LOS	C	D	C	C	C	C	D	D	C	C	C	A	C
	Movement Volume	31	252	117	102	222	18	135	105	109	43	108	36	1278
	Movement 95th Queue (ft)	352	352	53	273	273	34	308	308	55	183	183	52	
	Storage Bay Distance (ft)	0	0	25	0	0	25	0	0	25	0	0	25	
	Approach Delay (sec/veh)	34.3			31.5			34.9			25.2			
Approach LOS	C			C			C			C				

Forecast Year 2030 Modified Signal Timing - FRI Peak Hour

Intersection	MOE	Eastbound Approach			Westbound Approach			Northbound Approach			Southbound Approach			Intersection Total
		EBL	EBT	EBR	WBL	WBT	WBR	NBL	NBT	NBR	SBL	SBT	SBR	
US 169 & MN 210	Movement Delay (sec/veh)	69.3	61.8	48.7	101.8	99.7	95.2	91.6	96.8	82.1	75.3	62.6	43.3	79.4
	Total Delay (hr)	0.5	5.4	2.0	4.6	8.2	1.1	3.8	4.0	4.4	1.2	3.0	0.3	38.5
	Movement LOS	E	E	D	F	F	F	F	F	F	E	E	D	E
	Movement Volume	25	304	141	151	272	36	140	141	185	57	171	29	1652
	Movement 95th Queue (ft)	607	607	55	883	883	47	884	884	60	448	448	46	
	Storage Bay Distance (ft)	0	0	25	0	0	25	0	0	25	0	0	25	
	Approach Delay (sec/veh)	58.3			100.0			89.4			63.2			
Approach LOS	E			F			F			E				

Forecast Year 2030 Modified Signal Timing - SUN Peak Hour

Intersection	MOE	Eastbound Approach			Westbound Approach			Northbound Approach			Southbound Approach			Intersection Total
		EBL	EBT	EBR	WBL	WBT	WBR	NBL	NBT	NBR	SBL	SBT	SBR	
US 169 & MN 210	Movement Delay (sec/veh)	44.7	40.0	31.1	55.5	53.7	50.1	45.1	46.4	29.4	37.0	37.2	14.8	43.2
	Total Delay (hr)	0.3	3.7	1.3	3.7	3.9	0.4	1.3	1.1	1.1	0.3	0.8	0.1	18.0
	Movement LOS	D	D	C	E	D	D	D	D	C	D	D	B	D
	Movement Volume	27	319	145	224	241	29	102	81	128	32	79	25	1432
	Movement 95th Queue (ft)	404	404	53	513	513	43	308	308	55	166	166	43	
	Storage Bay Distance (ft)	0	0	25	0	0	25	0	0	25	0	0	25	
	Approach Delay (sec/veh)	37.6			54.3			39.0			33.0			
Approach LOS	D			D			D			C				

Forecast Year 2030 Modified Signal Timing + Right-Turn Lanes - AM Peak Hour

Intersection	MOE	Eastbound Approach			Westbound Approach			Northbound Approach			Southbound Approach			Intersection Total
		EBL	EBT	EBR	WBL	WBT	WBR	NBL	NBT	NBR	SBL	SBT	SBR	
US 169 & MN 210	Movement Delay (sec/veh)	25.5	27.3	12.0	28.2	26.9	17.2	29.6	30.7	12.0	23.4	20.6	5.5	23.5
	Total Delay (hr)	0.1	1.4	0.5	0.7	1.8	0.2	0.8	1.1	0.2	0.2	0.7	0.0	7.7
	Movement LOS	C	C	B	C	C	B	C	C	B	C	C	A	C
	Movement Volume	20	179	134	81	229	40	91	123	63	24	126	23	1133
	Movement 95th Queue (ft)	239	239	120	229	229	76	240	240	109	149	149	58	
	Storage Bay Distance (ft)	0	0	75	0	0	75	0	0	75	0	0	75	
	Approach Delay (sec/veh)	21.0			26.1			26.1			19.0			
	Approach LOS	C			C			C			B			

Forecast Year 2030 Modified Signal Timing + Right-Turn Lanes - PM Peak Hour

Intersection	MOE	Eastbound Approach			Westbound Approach			Northbound Approach			Southbound Approach			Intersection Total
		EBL	EBT	EBR	WBL	WBT	WBR	NBL	NBT	NBR	SBL	SBT	SBR	
US 169 & MN 210	Movement Delay (sec/veh)	29.5	33.4	15.4	27.1	27.7	17.9	32.4	34.0	14.7	28.1	23.4	5.7	26.5
	Total Delay (hr)	0.3	2.4	0.5	0.8	1.8	0.1	1.3	1.0	0.5	0.3	0.7	0.1	9.8
	Movement LOS	C	C	B	C	C	B	C	C	B	C	C	A	C
	Movement Volume	31	252	117	102	222	18	135	105	109	43	108	36	1278
	Movement 95th Queue (ft)	282	282	121	231	231	39	247	247	129	147	147	63	
	Storage Bay Distance (ft)	0	0	75	0	0	75	0	0	75	0	0	75	
	Approach Delay (sec/veh)	27.8			27.0			27.4			21.1			
	Approach LOS	C			C			C			C			

Forecast Year 2030 Modified Signal Timing + Right-Turn Lanes - FRI Peak Hour

Intersection	MOE	Eastbound Approach			Westbound Approach			Northbound Approach			Southbound Approach			Intersection Total
		EBL	EBT	EBR	WBL	WBT	WBR	NBL	NBT	NBR	SBL	SBT	SBR	
US 169 & MN 210	Movement Delay (sec/veh)	46.2	45.1	24.5	47.2	45.6	29.5	45.4	44.7	24.8	39.1	36.3	11.0	39.3
	Total Delay (hr)	0.3	3.9	1.0	2.1	3.7	0.3	1.9	1.8	1.3	0.6	1.7	0.1	18.7
	Movement LOS	D	D	C	D	D	C	D	D	C	D	D	B	D
	Movement Volume	25	304	141	151	272	36	140	141	185	57	171	29	1652
	Movement 95th Queue (ft)	449	449	131	437	437	83	411	411	134	267	267	87	
	Storage Bay Distance (ft)	0	0	75	0	0	75	0	0	75	0	0	75	
	Approach Delay (sec/veh)	39.0			44.9			37.0			34.1			
	Approach LOS	D			D			D			C			

Forecast Year 2030 Modified Signal Timing + Right-Turn Lanes - SUN Peak Hour

Intersection	MOE	Eastbound Approach			Westbound Approach			Northbound Approach			Southbound Approach			Intersection Total
		EBL	EBT	EBR	WBL	WBT	WBR	NBL	NBT	NBR	SBL	SBT	SBR	
US 169 & MN 210	Movement Delay (sec/veh)	31.6	31.8	17.4	34.6	34.6	28.0	36.4	34.4	14.9	30.8	28.4	6.1	29.5
	Total Delay (hr)	0.2	2.9	0.7	2.3	2.5	0.2	1.1	0.8	0.5	0.3	0.6	0.0	12.1
	Movement LOS	C	C	B	C	C	C	D	C	B	C	C	A	C
	Movement Volume	27	319	145	224	241	29	102	81	128	32	79	25	1432
	Movement 95th Queue (ft)	351	351	130	306	306	85	209	209	122	120	120	61	
	Storage Bay Distance (ft)	0	0	75	0	0	75	0	0	75	0	0	75	
	Approach Delay (sec/veh)	27.5			34.2			27.0			24.9			
	Approach LOS	C			C			C			C			

2030 Mini Roundabout - Weekday Peak Hours

Traffic Control	Intersection	Approach or Movement	AM Peak Hour										PM Peak Hour									
			EB		WB		NB		SB		Intersection		EB		WB		NB		SB		Intersection	
			Delay (s/v)	LOS	Delay (s/v)	LOS	Delay (s/v)	LOS	Delay (s/v)	LOS	Delay (s/v)	LOS	Delay (s/v)	LOS	Delay (s/v)	LOS	Delay (s/v)	LOS	Delay (s/v)	LOS	Delay (s/v)	LOS
Roundabout	US 169 & MN 210	Approach	2.7	A	2.4	A	2.1	A	1.9	A	2.3	A	3.6	A	3.2	A	2.3	A	2.8	A	3.1	A
		Left	2.6	A	2.6	A	2.1	A	2.0	A	2.3	A	3.5	A	3.2	A	2.2	A	2.8	A	3.1	A
		Through	2.7	A	2.4	A	2.1	A	1.9	A	2.3	A	3.5	A	3.3	A	2.3	A	2.8	A	3.1	A
		Right	2.8	A	2.5	A	1.7	A	1.8	A	2.3	A	3.7	A	3.1	A	2.2	A	3.0	A	3.1	A

2030 Mini Roundabout - Weekend Peak Hours

Traffic Control	Intersection	Approach or Movement	FRI Peak Hour										SUN Peak Hour									
			EB		WB		NB		SB		Intersection		EB		WB		NB		SB		Intersection	
			Delay (s/v)	LOS	Delay (s/v)	LOS	Delay (s/v)	LOS	Delay (s/v)	LOS	Delay (s/v)	LOS	Delay (s/v)	LOS	Delay (s/v)	LOS	Delay (s/v)	LOS	Delay (s/v)	LOS	Delay (s/v)	LOS
Roundabout	US 169 & MN 210	Approach	5.8	A	4.4	A	3.3	A	4.1	A	4.5	A	4.0	A	2.8	A	2.3	A	3.5	A	3.2	A
		Left	5.8	A	4.5	A	3.6	A	4.0	A	4.5	A	3.9	A	3.0	A	2.4	A	3.4	A	3.2	A
		Through	5.7	A	4.4	A	3.2	A	4.1	A	4.5	A	4.0	A	2.8	A	2.2	A	3.5	A	3.2	A
		Right	5.8	A	4.3	A	2.8	A	4.1	A	4.5	A	4.0	A	2.8	A	2.2	A	3.5	A	3.2	A

Forecast Year 2030 Truck Route - AM Peak Hour

Intersection	MOE	Eastbound Approach			Westbound Approach			Northbound Approach			Southbound Approach			Intersection Total
		EBL	EBT	EBR	WBL	WBT	WBR	NBL	NBT	NBR	SBL	SBT	SBR	
US 169 & MN 210	Movement Delay (sec/veh)	24.4	26.7	16.0	33.2	27.8	24.4	28.8	30.4	17.8	24.2	20.6	7.0	24.8
	Total Delay (hr)	0.1	1.4	0.7	0.7	1.8	0.3	0.8	1.1	0.3	0.1	0.8	0.0	8.1
	Movement LOS	C	C	B	C	C	C	C	C	B	C	C	A	C
	Movement Volume	17	179	148	73	221	38	100	126	64	22	130	20	1138
	Movement 95th Queue (ft)	220	220	46	216	216	46	227	227	53	129	129	39	
	Storage Bay Distance (ft)	0	0	25	0	0	25	0	0	25	0	0	25	
	Approach Delay (sec/veh)	22.0			28.6			27.1			19.5			
Approach LOS	C			C			C			B				

Forecast Year 2030 Truck Route - PM Peak Hour

Intersection	MOE	Eastbound Approach			Westbound Approach			Northbound Approach			Southbound Approach			Intersection Total
		EBL	EBT	EBR	WBL	WBT	WBR	NBL	NBT	NBR	SBL	SBT	SBR	
US 169 & MN 210	Movement Delay (sec/veh)	30.1	30.1	18.6	30.7	30.0	24.0	32.6	29.2	21.4	22.3	22.5	9.2	26.9
	Total Delay (hr)	0.2	2.1	0.6	0.9	1.7	0.1	1.3	0.9	0.7	0.2	0.7	0.1	9.5
	Movement LOS	C	C	B	C	C	C	C	C	C	C	C	A	C
	Movement Volume	27	240	116	102	195	19	136	102	109	36	113	36	1231
	Movement 95th Queue (ft)	262	262	51	230	230	36	240	240	51	134	134	47	
	Storage Bay Distance (ft)	0	0	25	0	0	25	0	0	25	0	0	25	
	Approach Delay (sec/veh)	26.6			29.9			28.1			19.9			
Approach LOS	C			C			C			B				

Forecast Year 2030 Truck Route - FRI Peak Hour

Intersection	MOE	Eastbound Approach			Westbound Approach			Northbound Approach			Southbound Approach			Intersection Total
		EBL	EBT	EBR	WBL	WBT	WBR	NBL	NBT	NBR	SBL	SBT	SBR	
US 169 & MN 210	Movement Delay (sec/veh)	45.2	43.5	31.7	74.1	68.7	66.8	48.0	51.1	37.9	37.9	36.7	21.5	49.1
	Total Delay (hr)	0.3	3.5	1.3	3.0	5.5	0.8	1.9	1.9	1.9	0.6	1.6	0.2	22.5
	Movement LOS	D	D	C	E	E	E	D	D	D	D	D	C	D
	Movement Volume	26	283	146	139	272	40	136	132	179	53	159	28	1593
	Movement 95th Queue (ft)	415	415	49	584	584	49	444	444	49	258	258	46	
	Storage Bay Distance (ft)	0	0	25	0	0	25	0	0	25	0	0	25	
	Approach Delay (sec/veh)	39.8			70.2			44.9			35.2			
Approach LOS	D			E			D			D				

Forecast Year 2030 Truck Route - SUN Peak Hour

Intersection	MOE	Eastbound Approach			Westbound Approach			Northbound Approach			Southbound Approach			Intersection Total
		EBL	EBT	EBR	WBL	WBT	WBR	NBL	NBT	NBR	SBL	SBT	SBR	
US 169 & MN 210	Movement Delay (sec/veh)	29.2	31.2	23.1	62.4	57.8	60.8	41.2	40.6	26.7	32.3	33.0	10.9	41.1
	Total Delay (hr)	0.2	2.8	1.0	4.2	4.2	0.6	1.2	1.0	1.0	0.3	0.7	0.1	17.3
	Movement LOS	C	C	C	E	E	E	D	D	C	C	C	B	D
	Movement Volume	24	314	144	226	245	35	99	83	128	34	76	25	1433
	Movement 95th Queue (ft)	351	351	49	572	572	49	282	282	52	143	143	44	
	Storage Bay Distance (ft)	0	0	25	0	0	25	0	0	25	0	0	25	
	Approach Delay (sec/veh)	28.7			60.1			35.1			28.7			
Approach LOS	C			E			D			C				

Forecast Year 2050 All-Way Stop - AM Peak Hour

Intersection	MOE	Eastbound Approach			Westbound Approach			Northbound Approach			Southbound Approach			Intersection Total
		EBL	EBT	EBR	WBL	WBT	WBR	NBL	NBT	NBR	SBL	SBT	SBR	
US 169 & MN 210	Movement Delay (sec/veh)	17.2	21.3	20.5	60.8	61.9	59.0	31.9	35.1	24.0	13.4	16.8	8.1	34.6
	Total Delay (hr)	0.1	1.3	1.0	1.7	4.9	0.7	1.1	1.5	0.5	0.1	0.7	0.1	13.7
	Movement LOS	C	C	C	F	F	F	D	E	C	B	C	A	D
	Movement Volume	27	224	177	97	271	41	120	147	77	30	148	25	1384
	Movement 95th Queue (ft)	208	208	60	594	594	60	303	303	58	127	127	56	
	Storage Bay Distance (ft)	0	0	25	0	0	25	0	0	25	0	0	25	
	Approach Delay (sec/veh)	20.7			61.3			31.5			15.2			
Approach LOS	C			F			D			C				

Forecast Year 2050 All-Way Stop - PM Peak Hour

Intersection	MOE	Eastbound Approach			Westbound Approach			Northbound Approach			Southbound Approach			Intersection Total
		EBL	EBT	EBR	WBL	WBT	WBR	NBL	NBT	NBR	SBL	SBT	SBR	
US 169 & MN 210	Movement Delay (sec/veh)	62.0	66.5	55.7	92.4	89.7	74.4	36.2	39.9	34.0	18.0	20.8	11.0	56.7
	Total Delay (hr)	0.7	6.0	2.3	3.8	7.1	0.4	1.7	1.5	1.3	0.2	0.8	0.1	25.9
	Movement LOS	F	F	F	F	F	F	E	E	D	C	C	B	F
	Movement Volume	39	314	145	134	271	20	164	126	128	50	137	43	1571
	Movement 95th Queue (ft)	682	682	53	681	681	51	331	331	56	141	141	58	
	Storage Bay Distance (ft)	0	0	25	0	0	25	0	0	25	0	0	25	
	Approach Delay (sec/veh)	63.0			89.8			36.6			18.4			
Approach LOS	F			F			E			C				

Forecast Year 2050 All-Way Stop - FRI Peak Hour

Intersection	MOE	Eastbound Approach			Westbound Approach			Northbound Approach			Southbound Approach			Intersection Total
		EBL	EBT	EBR	WBL	WBT	WBR	NBL	NBT	NBR	SBL	SBT	SBR	
US 169 & MN 210	Movement Delay (sec/veh)	337.2	339.8	300.5	691.9	669.3	637.1	375.1	346.3	357.9	63.0	63.7	43.4	388.3
	Total Delay (hr)	3.4	35.5	14.4	37.5	69.3	7.6	19.4	18.6	23.1	1.4	3.7	0.4	234.3
	Movement LOS	F	F	F	F	F	F	F	F	F	F	F	E	F
	Movement Volume	33	364	164	172	329	39	175	183	222	78	208	32	1999
	Movement 95th Queue (ft)	2995	2995	52	5022	5022	57	2989	2989	55	422	422	55	
	Storage Bay Distance (ft)	0	0	25	0	0	25	0	0	25	0	0	25	
	Approach Delay (sec/veh)	328.2			674.2			359.4			61.5			
Approach LOS	F			F			F			F				

Forecast Year 2050 All-Way Stop - SUN Peak Hour

Intersection	MOE	Eastbound Approach			Westbound Approach			Northbound Approach			Southbound Approach			Intersection Total
		EBL	EBT	EBR	WBL	WBT	WBR	NBL	NBT	NBR	SBL	SBT	SBR	
US 169 & MN 210	Movement Delay (sec/veh)	71.8	82.8	74.1	433.6	402.5	439.5	22.9	24.6	19.9	14.2	14.9	7.4	176.9
	Total Delay (hr)	0.6	9.3	3.7	34.9	36.0	4.3	0.8	0.7	0.9	0.2	0.4	0.1	91.9
	Movement LOS	F	F	F	F	F	F	C	C	C	B	B	A	F
	Movement Volume	30	393	171	266	291	34	121	97	162	39	95	27	1726
	Movement 95th Queue (ft)	929	929	46	3465	3465	56	181	181	52	92	92	50	
	Storage Bay Distance (ft)	0	0	25	0	0	25	0	0	25	0	0	25	
	Approach Delay (sec/veh)	79.7			418.6			22.1			13.5			
Approach LOS	F			F			C			B				

Forecast Year 2050 Modified Signal Timing - AM Peak Hour

Intersection	MOE	Eastbound Approach			Westbound Approach			Northbound Approach			Southbound Approach			Intersection Total
		EBL	EBT	EBR	WBL	WBT	WBR	NBL	NBT	NBR	SBL	SBT	SBR	
US 169 & MN 210	Movement Delay (sec/veh)	37.3	43.1	36.2	54.7	51.7	47.8	55.6	58.9	37.7	40.0	34.5	17.1	45.7
	Total Delay (hr)	0.3	2.7	1.8	1.6	4.1	0.6	1.9	2.5	0.8	0.3	1.4	0.1	18.1
	Movement LOS	D	D	D	D	D	D	E	E	D	D	C	B	D
	Movement Volume	27	224	177	97	271	41	120	147	77	30	148	25	1384
	Movement 95th Queue (ft)	448	448	61	518	518	48	499	499	58	237	237	48	
	Storage Bay Distance (ft)	0	0	25	0	0	25	0	0	25	0	0	25	
	Approach Delay (sec/veh)	39.9			52.0			53.0			33.2			
	Approach LOS	D			D			D			C			

Forecast Year 2050 Modified Signal Timing - PM Peak Hour

Intersection	MOE	Eastbound Approach			Westbound Approach			Northbound Approach			Southbound Approach			Intersection Total
		EBL	EBT	EBR	WBL	WBT	WBR	NBL	NBT	NBR	SBL	SBT	SBR	
US 169 & MN 210	Movement Delay (sec/veh)	50.8	57.0	49.4	66.8	64.7	55.4	61.9	60.3	53.0	46.3	46.4	29.7	56.7
	Total Delay (hr)	0.6	5.2	2.1	2.8	5.2	0.3	2.9	2.2	2.0	0.6	1.8	0.4	26.1
	Movement LOS	D	E	D	E	E	E	E	E	D	D	D	C	E
	Movement Volume	39	314	145	134	271	20	164	126	128	50	137	43	1571
	Movement 95th Queue (ft)	588	588	55	547	547	36	499	499	58	283	283	54	
	Storage Bay Distance (ft)	0	0	25	0	0	25	0	0	25	0	0	25	
	Approach Delay (sec/veh)	54.3			64.9			58.7			43.3			
	Approach LOS	D			E			E			D			

Forecast Year 2050 Modified Signal Timing - FRI Peak Hour

Intersection	MOE	Eastbound Approach			Westbound Approach			Northbound Approach			Southbound Approach			Intersection Total
		EBL	EBT	EBR	WBL	WBT	WBR	NBL	NBT	NBR	SBL	SBT	SBR	
US 169 & MN 210	Movement Delay (sec/veh)	110.3	105.4	93.5	542.9	530.7	491.0	600.4	537.3	557.6	147.5	140.5	103.7	356.9
	Total Delay (hr)	1.1	11.1	4.5	29.3	54.1	5.9	30.7	28.4	35.3	3.2	8.2	1.0	212.8
	Movement LOS	F	F	F	F	F	F	F	F	F	F	F	F	F
	Movement Volume	33	364	164	172	329	39	172	180	217	78	208	32	1988
	Movement 95th Queue (ft)	1111	1111	56	4444	4444	44	4494	4494	60	989	989	47	
	Storage Bay Distance (ft)	0	0	25	0	0	25	0	0	25	0	0	25	
	Approach Delay (sec/veh)	102.2			531.7			564.1			138.5			
	Approach LOS	F			F			F			F			

Forecast Year 2050 Modified Signal Timing - SUN Peak Hour

Intersection	MOE	Eastbound Approach			Westbound Approach			Northbound Approach			Southbound Approach			Intersection Total
		EBL	EBT	EBR	WBL	WBT	WBR	NBL	NBT	NBR	SBL	SBT	SBR	
US 169 & MN 210	Movement Delay (sec/veh)	64.8	62.4	54.1	432.3	401.9	426.3	56.5	58.7	41.6	49.0	46.8	23.9	178.7
	Total Delay (hr)	0.6	7.1	2.7	34.6	35.4	4.1	2.0	1.7	2.0	0.5	1.3	0.2	92.2
	Movement LOS	E	E	D	F	F	F	E	E	D	D	D	C	F
	Movement Volume	30	393	171	266	291	34	121	97	162	39	95	27	1726
	Movement 95th Queue (ft)	715	715	54	3716	3716	44	434	434	55	221	221	46	
	Storage Bay Distance (ft)	0	0	25	0	0	25	0	0	25	0	0	25	
	Approach Delay (sec/veh)	60.1			417.0			50.7			43.5			
	Approach LOS	E			F			D			D			

Forecast Year 2050 Modified Signal Timing + Right-Turn Lanes - AM Peak Hour

Intersection	MOE	Eastbound Approach			Westbound Approach			Northbound Approach			Southbound Approach			Intersection Total
		EBL	EBT	EBR	WBL	WBT	WBR	NBL	NBT	NBR	SBL	SBT	SBR	
US 169 & MN 210	Movement Delay (sec/veh)	32.8	36.4	19.4	40.6	38.4	28.4	39.3	38.3	15.6	24.4	26.6	6.3	32.0
	Total Delay (hr)	0.3	2.3	1.0	1.2	3.0	0.3	1.4	1.6	0.3	0.2	1.1	0.0	12.7
	Movement LOS	C	D	B	D	D	C	D	D	B	C	C	A	C
	Movement Volume	27	224	177	97	271	41	120	147	77	30	148	25	1384
	Movement 95th Queue (ft)	350	350	128	431	431	89	332	332	123	186	186	63	
	Storage Bay Distance (ft)	0	0	75	0	0	75	0	0	75	0	0	75	
	Approach Delay (sec/veh)	29.1			37.9			33.6			23.8			
	Approach LOS	C			D			C			C			

Forecast Year 2050 Modified Signal Timing + Right-Turn Lanes - PM Peak Hour

Intersection	MOE	Eastbound Approach			Westbound Approach			Northbound Approach			Southbound Approach			Intersection Total
		EBL	EBT	EBR	WBL	WBT	WBR	NBL	NBT	NBR	SBL	SBT	SBR	
US 169 & MN 210	Movement Delay (sec/veh)	42.6	44.5	24.2	45.6	43.4	29.9	43.1	42.0	23.2	38.7	34.0	9.1	38.1
	Total Delay (hr)	0.5	4.0	1.0	1.9	3.4	0.2	2.0	1.6	0.9	0.5	1.3	0.1	17.4
	Movement LOS	D	D	C	D	D	C	D	D	C	D	C	A	D
	Movement Volume	39	314	145	134	271	20	164	126	128	50	137	43	1571
	Movement 95th Queue (ft)	470	470	133	399	399	65	387	387	135	215	215	98	
	Storage Bay Distance (ft)	0	0	75	0	0	75	0	0	75	0	0	75	
	Approach Delay (sec/veh)	38.4			43.5			36.7			30.4			
	Approach LOS	D			D			D			C			

Forecast Year 2050 Modified Signal Timing + Right-Turn Lanes - FRI Peak Hour

Intersection	MOE	Eastbound Approach			Westbound Approach			Northbound Approach			Southbound Approach			Intersection Total
		EBL	EBT	EBR	WBL	WBT	WBR	NBL	NBT	NBR	SBL	SBT	SBR	
US 169 & MN 210	Movement Delay (sec/veh)	90.3	84.4	62.8	274.5	274.5	229.0	315.3	292.0	269.8	89.8	77.1	44.7	191.8
	Total Delay (hr)	0.9	8.9	3.0	14.5	27.5	2.7	16.3	15.6	17.3	1.9	4.5	0.4	113.5
	Movement LOS	F	F	E	F	F	F	F	F	F	F	E	D	F
	Movement Volume	33	364	164	172	329	39	175	183	222	78	208	32	1999
	Movement 95th Queue (ft)	917	917	132	2473	2473	103	2753	2753	137	622	622	99	
	Storage Bay Distance (ft)	0	0	75	0	0	75	0	0	75	0	0	75	
	Approach Delay (sec/veh)	78.4			271.2			290.5			77.0			
	Approach LOS	E			F			F			E			

Forecast Year 2050 Modified Signal Timing + Right-Turn Lanes - SUN Peak Hour

Intersection	MOE	Eastbound Approach			Westbound Approach			Northbound Approach			Southbound Approach			Intersection Total
		EBL	EBT	EBR	WBL	WBT	WBR	NBL	NBT	NBR	SBL	SBT	SBR	
US 169 & MN 210	Movement Delay (sec/veh)	45.4	43.5	28.4	97.6	91.9	86.4	46.6	49.4	23.4	36.1	38.5	7.8	57.0
	Total Delay (hr)	0.4	4.9	1.4	7.7	8.0	0.8	1.7	1.4	1.1	0.4	1.0	0.1	28.9
	Movement LOS	D	D	C	F	F	F	D	D	C	D	D	A	E
	Movement Volume	30	393	171	266	291	34	121	97	162	39	95	27	1726
	Movement 95th Queue (ft)	538	538	133	1037	1037	106	345	345	131	169	169	74	
	Storage Bay Distance (ft)	0	0	75	0	0	75	0	0	75	0	0	75	
	Approach Delay (sec/veh)	39.2			94.1			37.4			32.8			
	Approach LOS	D			F			D			C			

2050 Mini Roundabout - Weekday Peak Hours

Traffic Control	Intersection	Approach or Movement	AM Peak Hour										PM Peak Hour									
			EB		WB		NB		SB		Intersection		EB		WB		NB		SB		Intersection	
			Delay (s/v)	LOS	Delay (s/v)	LOS	Delay (s/v)	LOS	Delay (s/v)	LOS	Delay (s/v)	LOS	Delay (s/v)	LOS	Delay (s/v)	LOS	Delay (s/v)	LOS	Delay (s/v)	LOS	Delay (s/v)	LOS
Roundabout	US 169 & MN 210	Approach	3.6	A	3.1	A	2.7	A	2.5	A	3.0	A	5.2	A	4.8	A	3.3	A	4.0	A	4.5	A
		Left	3.7	A	3.1	A	2.3	A	2.5	A			5.3	A	4.9	A	3.3	A	4.0	A		
		Through	3.7	A	2.9	A	2.8	A	2.6	A			5.0	A	4.7	A	3.3	A	4.1	A		
		Right	3.4	A	3.2	A	2.3	A	2.4	A			5.3	A	4.7	A	3.3	A	3.5	A		

2050 Mini Roundabout - Weekend Peak Hours

Traffic Control	Intersection	Approach or Movement	FRI Peak Hour										SUN Peak Hour									
			EB		WB		NB		SB		Intersection		EB		WB		NB		SB		Intersection	
			Delay (s/v)	LOS	Delay (s/v)	LOS	Delay (s/v)	LOS	Delay (s/v)	LOS	Delay (s/v)	LOS	Delay (s/v)	LOS	Delay (s/v)	LOS	Delay (s/v)	LOS	Delay (s/v)	LOS	Delay (s/v)	LOS
Roundabout	US 169 & MN 210	Approach	9.8	A	7.4	A	4.4	A	7.2	A	7.6	A	5.9	A	4.2	A	2.6	A	5.9	A	5.0	A
		Left	9.5	A	7.9	A	4.7	A	7.2	A			6.1	A	4.5	A	2.8	A	5.8	A		
		Through	10.1	B	7.5	A	4.3	A	7.3	A			6.0	A	4.2	A	2.5	A	5.9	A		
		Right	9.7	A	7.2	A	4.1	A	7.3	A			5.7	A	4.2	A	2.8	A	6.0	A		

Forecast Year 2050 Truck Route - AM Peak Hour

Intersection	MOE	Eastbound Approach			Westbound Approach			Northbound Approach			Southbound Approach			Intersection Total
		EBL	EBT	EBR	WBL	WBT	WBR	NBL	NBT	NBR	SBL	SBT	SBR	
US 169 & MN 210	Movement Delay (sec/veh)	27.4	31.0	19.8	40.9	35.4	31.2	34.1	33.2	22.2	24.0	24.2	10.8	29.8
	Total Delay (hr)	0.1	1.8	0.9	1.0	2.6	0.4	1.2	1.3	0.4	0.2	0.9	0.1	10.9
	Movement LOS	C	C	B	D	D	C	C	C	C	C	C	B	C
	Movement Volume	18	199	165	86	253	45	127	140	70	30	129	28	1290
	Movement 95th Queue (ft)	271	271	48	306	306	47	281	281	52	147	147	42	
	Storage Bay Distance (ft)	0	0	25	0	0	25	0	0	25	0	0	25	
	Approach Delay (sec/veh)	26.0			36.1			31.3			22.2			
	Approach LOS	C			D			C			C			

Forecast Year 2050 Truck Route - PM Peak Hour

Intersection	MOE	Eastbound Approach			Westbound Approach			Northbound Approach			Southbound Approach			Intersection Total
		EBL	EBT	EBR	WBL	WBT	WBR	NBL	NBT	NBR	SBL	SBT	SBR	
US 169 & MN 210	Movement Delay (sec/veh)	44.0	43.7	33.4	67.5	63.8	69.7	57.4	65.0	50.0	41.4	37.2	18.4	51.0
	Total Delay (hr)	0.4	3.8	1.4	2.6	5.2	0.5	2.7	2.3	1.8	0.6	1.5	0.2	23.0
	Movement LOS	D	D	C	E	E	E	E	E	D	D	D	B	D
	Movement Volume	32	304	143	132	280	26	165	123	129	51	144	46	1575
	Movement 95th Queue (ft)	450	450	49	559	559	42	603	603	51	264	264	49	
	Storage Bay Distance (ft)	0	0	25	0	0	25	0	0	25	0	0	25	
	Approach Delay (sec/veh)	40.6			65.3			57.4			34.5			
	Approach LOS	D			E			E			C			

Forecast Year 2050 Truck Route - FRI Peak Hour

Intersection	MOE	Eastbound Approach			Westbound Approach			Northbound Approach			Southbound Approach			Intersection Total
		EBL	EBT	EBR	WBL	WBT	WBR	NBL	NBT	NBR	SBL	SBT	SBR	
US 169 & MN 210	Movement Delay (sec/veh)	67.8	59.9	50.5	553.2	547.4	525.3	305.4	287.7	270.1	82.3	69.6	52.3	262.9
	Total Delay (hr)	0.6	6.0	2.5	28.4	55.5	7.0	14.3	13.3	17.8	1.4	3.8	0.5	151.1
	Movement LOS	E	E	D	F	F	F	F	F	F	F	E	D	F
	Movement Volume	30	346	169	168	332	45	161	164	228	61	196	32	1932
	Movement 95th Queue (ft)	659	659	47	4543	4543	44	2034	2034	51	463	463	46	
	Storage Bay Distance (ft)	0	0	25	0	0	25	0	0	25	0	0	25	
	Approach Delay (sec/veh)	57.4			547.4			285.6			70.4			
	Approach LOS	E			F			F			E			

Forecast Year 2050 Truck Route - SUN Peak Hour

Intersection	MOE	Eastbound Approach			Westbound Approach			Northbound Approach			Southbound Approach			Intersection Total
		EBL	EBT	EBR	WBL	WBT	WBR	NBL	NBT	NBR	SBL	SBT	SBR	
US 169 & MN 210	Movement Delay (sec/veh)	43.9	41.5	34.6	476.7	442.3	496.1	52.1	50.1	37.1	40.1	39.6	16.0	189.0
	Total Delay (hr)	0.4	4.5	1.7	38.8	40.5	5.9	1.8	1.5	1.7	0.4	1.1	0.1	98.4
	Movement LOS	D	D	C	F	F	F	D	D	D	D	D	B	F
	Movement Volume	28	380	172	269	299	43	122	100	159	37	97	28	1734
	Movement 95th Queue (ft)	478	478	46	3900	3900	46	398	398	50	183	183	46	
	Storage Bay Distance (ft)	0	0	25	0	0	25	0	0	25	0	0	25	
	Approach Delay (sec/veh)	39.6			461.2			45.3			35.6			
	Approach LOS	D			F			D			D			

APPENDIX G: SAFETY ANALYSIS RESULTS

US 169 & MN 210 (W JCT)
Crash Cost Analysis

	Right Angle	Left Turn	Rear End	Sideswipe	Run Off Road	Head On	Right Turn	Other	Total
All Crashes	2	6	3	9	1	1	1	5	23
Fatal	0	0	0	0	0	0	0	0	
A Injury	0	0	0	0	0	0	0	1	
B Injury	0	1	0	0	0	0	0	3	
C Injury	0	1	2	1	1	0	0	1	23
PDO	2	4	1	8	0	1	1	0	
Cross-Street Crashes	0	0	0	0	0	0	0	0	0
Fatal									
A Injury									
B Injury									
C Injury									0
PDO									
Alternative 0 (No Build)									
Total Crashes	2.0	6.0	3.0	9.0	1.0	1.0	1.0	5.0	28.0
Fatal	0.0	0.0	0.0	0.0	0.0	0.0	0.0	0.0	0.0
C Injury	0.0	0.0	0.0	0.0	0.0	0.0	0.0	1.0	1.0
B Injury	0.0	1.0	0.0	0.0	0.0	0.0	0.0	3.0	4.0
C Injury	0.0	1.0	2.0	1.0	1.0	0.0	0.0	1.0	6.0
PDO	2.0	4.0	1.0	8.0	0.0	1.0	1.0	0.0	17.0
									Crash Rate = 0.52
Alternative 1 All-Way Stop									
No Change									
Total Crashes	2.0	6.0	3.0	9.0	1.0	1.0	1.0	5.0	28.0
Fatal	0.0	0.0	0.0	0.0	0.0	0.0	0.0	0.0	0.0
A Injury	0.0	0.0	0.0	0.0	0.0	0.0	0.0	1.0	1.0
B Injury	0.0	1.0	0.0	0.0	0.0	0.0	0.0	3.0	4.0
C Injury	0.0	1.0	2.0	1.0	1.0	0.0	0.0	1.0	6.0
PDO	2.0	4.0	1.0	8.0	0.0	1.0	1.0	0.0	17.0
									Crash Rate = 0.52
Alternative 2 Modified Signal Timing									
No Change									
Total Crashes	2.0	6.0	3.0	9.0	1.0	1.0	1.0	5.0	28.0
Fatal	0.0	0.0	0.0	0.0	0.0	0.0	0.0	0.0	0.0
A Injury	0.0	0.0	0.0	0.0	0.0	0.0	0.0	1.0	1.0
B Injury	0.0	1.0	0.0	0.0	0.0	0.0	0.0	3.0	4.0
C Injury	0.0	1.0	2.0	1.0	1.0	0.0	0.0	1.0	6.0
PDO	2.0	4.0	1.0	8.0	0.0	1.0	1.0	0.0	17.0
									Crash Rate = 0.52
Alternative 2A Modified Signal Timing + RTLS									
Eliminate RT Sideswipes, Collision with Parked Cars									
Total Crashes	2.0	6.0	3.0	2.0	1.0	1.0	1.0	5.0	21.0
Fatal	0.0	0.0	0.0	0.0	0.0	0.0	0.0	0.0	0.0
A Injury	0.0	0.0	0.0	0.0	0.0	0.0	0.0	1.0	1.0
B Injury	0.0	1.0	0.0	0.0	0.0	0.0	0.0	3.0	4.0
C Injury	0.0	1.0	2.0	1.0	1.0	0.0	0.0	1.0	6.0
PDO	2.0	4.0	1.0	3.0	0.0	1.0	1.0	0.0	10.0
									Crash Rate = 0.39
Alternative 3 Mini Roundabout									
Use Statewide Average for Single-Lane RAB									
Total Crashes									
Fatal									
A Injury									
B Injury									
C Injury									
PDO									
									Crash Rate = 0.32
Alternative 4 Truck Route									
Eliminate crashes that involve a HCV									
Total Crashes	2.0	6.0	3.0	4.0	1.0	0.0	1.0	5.0	22.0
Fatal	0.0	0.0	0.0	0.0	0.0	0.0	0.0	0.0	0.0
A Injury	0.0	0.0	0.0	0.0	0.0	0.0	0.0	1.0	1.0
B Injury	0.0	1.0	0.0	0.0	0.0	0.0	0.0	3.0	4.0
C Injury	0.0	1.0	2.0	1.0	1.0	0.0	0.0	1.0	6.0
PDO	2.0	4.0	1.0	3.0	0.0	0.0	1.0	0.0	11.0
									Crash Rate = 0.40

2030 Annual Crash Costs

Scenario	Traffic Control	Severity	Severity Proportion	Crash Rate	Total Entering Volume	Average Crashes / Year (No.)	Cost / Crash (\$)	Cost / Year (\$)
Alternative 0 (No Build)	Traffic Signal	K	0.0%	0.52	5,570,020	0.000	\$ 15,900,000	\$ -
		A	3.6%			0.100	\$ 1,700,000	\$ 170,000.00
		B	14.3%			0.400	\$ 380,000	\$ 152,000.00
		C	21.4%			0.600	\$ 180,000	\$ 108,000.00
		PDO	60.7%			1.700	\$ 18,000	\$ 30,600.00
		Total	100%			2.800	\$ 460,600.00	
Alternative 1 All-Way Stop	0	K	0.0%	0.52	5,570,020	0.000	\$ 15,900,000	\$ -
		A	3.6%			0.100	\$ 1,700,000	\$ 170,000.00
		B	14.3%			0.400	\$ 380,000	\$ 152,000.00
		C	21.4%			0.600	\$ 180,000	\$ 108,000.00
		PDO	60.7%			1.700	\$ 18,000	\$ 30,600.00
		Total	100%			2.800	\$ 460,600.00	
Alternative 2 Modified Signal Timing	Traffic Signal	K	0.0%	0.52	5,570,020	0.000	\$ 15,900,000	\$ -
		A	3.6%			0.100	\$ 1,700,000	\$ 170,000.00
		B	14.3%			0.400	\$ 380,000	\$ 152,000.00
		C	21.4%			0.600	\$ 180,000	\$ 108,000.00
		PDO	60.7%			1.700	\$ 18,000	\$ 30,600.00
		Total	100%			2.800	\$ 460,600.00	
Alternative 2A Modified Signal Timing + RTLS	Traffic Signal	K	0.0%	0.39	5,570,020	0.000	\$ 15,900,000	\$ -
		A	4.8%			0.100	\$ 1,700,000	\$ 170,000.00
		B	19.0%			0.400	\$ 380,000	\$ 152,000.00
		C	28.6%			0.600	\$ 180,000	\$ 108,000.00
		PDO	47.6%			1.000	\$ 18,000	\$ 18,000.00
		Total	100%			2.100	\$ 448,000.00	
Alternative 3 Mini Roundabout	Roundabout	K	0.0%	0.32	5,570,020	0.000	\$ 15,900,000	\$ -
		A	1.0%			0.017	\$ 1,700,000	\$ 29,498.55
		B	6.8%			0.121	\$ 380,000	\$ 46,156.56
		C	16.8%			0.302	\$ 180,000	\$ 54,346.74
		PDO	75.5%			1.357	\$ 18,000	\$ 24,424.80
		Total	100%			1.798	\$ 154,426.65	
Alternative 4 Truck Route	Traffic Signal	K	0.0%	0.40	5,570,020	0.000	\$ 15,900,000	\$ -
		A	4.5%			0.100	\$ 1,700,000	\$ 170,000.00
		B	18.2%			0.400	\$ 380,000	\$ 152,000.00
		C	27.3%			0.600	\$ 180,000	\$ 108,000.00
		PDO	50.0%			1.100	\$ 18,000	\$ 19,800.00
		Total	100%			2.200	\$ 449,800.00	

Cost/Crash reflects MnDOT's Cost-Effectiveness & Benefit-Cost Analysis for Transportation Projects Appendix A, published July 2021. (http://www.dot.state.mn.us/planning/program/appendix_a.html)

2050 Annual Crash Costs

Scenario	Traffic Control	Severity	Severity Proportion	Crash Rate	Total Entering Volume	Average Crashes / Year (No.)	Cost / Crash (\$)	Cost / Year (\$)
Alternative 0 (No Build)	Traffic Signal	K	0.0%	0.52	6,154,022	0.000	\$ 15,900,000	N/A
		A	3.6%			0.113	\$ 1,700,000	\$ 192,576.00
		B	14.3%			0.453	\$ 380,000	\$ 172,185.60
		C	21.4%			0.680	\$ 180,000	\$ 122,342.40
		PDO	60.7%			1.926	\$ 18,000	\$ 34,663.68
		Total	100%			3.172	\$ 521,767.68	
Alternative 1 All-Way Stop	0	K	0.0%	0.52	6,154,022	0.000	\$ 15,900,000	N/A
		A	3.6%			0.113	\$ 1,700,000	\$ 192,576.00
		B	14.3%			0.453	\$ 380,000	\$ 172,185.60
		C	21.4%			0.680	\$ 180,000	\$ 122,342.40
		PDO	60.7%			1.926	\$ 18,000	\$ 34,663.68
		Total	100%			3.172	\$ 521,767.68	
Alternative 2 Modified Signal Timing	Traffic Signal	K	0.0%	0.52	6,154,022	0.000	\$ 15,900,000	N/A
		A	3.6%			0.113	\$ 1,700,000	\$ 192,576.00
		B	14.3%			0.453	\$ 380,000	\$ 172,185.60
		C	21.4%			0.680	\$ 180,000	\$ 122,342.40
		PDO	60.7%			1.926	\$ 18,000	\$ 34,663.68
		Total	100%			3.172	\$ 521,767.68	
Alternative 2A Modified Signal Timing + RTLS	Traffic Signal	K	0.0%	0.39	6,154,022	0.000	\$ 15,900,000	N/A
		A	4.8%			0.113	\$ 1,700,000	\$ 192,576.00
		B	19.0%			0.453	\$ 380,000	\$ 172,185.60
		C	28.6%			0.680	\$ 180,000	\$ 122,342.40
		PDO	47.6%			1.133	\$ 18,000	\$ 20,390.40
		Total	100%			2.379	\$ 507,494.40	
Alternative 3 Mini Roundabout	Roundabout	K	0.0%	0.32	6,154,022	0.000	\$ 15,900,000	N/A
		A	1.0%			0.019	\$ 1,700,000	\$ 32,591.40
		B	6.8%			0.134	\$ 380,000	\$ 50,995.95
		C	16.8%			0.334	\$ 180,000	\$ 60,044.85
		PDO	75.5%			1.499	\$ 18,000	\$ 26,985.68
		Total	100%			1.986	\$ 170,617.88	
Alternative 4 Truck Route	Traffic Signal	K	0.0%	0.40	6,154,022	0.000	\$ 15,900,000	N/A
		A	4.5%			0.113	\$ 1,700,000	\$ 192,576.00
		B	18.2%			0.453	\$ 380,000	\$ 172,185.60
		C	27.3%			0.680	\$ 180,000	\$ 122,342.40
		PDO	50.0%			1.246	\$ 18,000	\$ 22,429.44
		Total	100%			2.492	\$ 509,533.44	

Cost/Crash reflects MnDOT's Cost-Effectiveness & Benefit-Cost Analysis for Transportation Projects Appendix A, published July 2021. (http://www.dot.state.mn.us/planning/program/appendix_a.html)

US 169 & MN 210 (W JCT) - Present Value Crash Benefit - 2050 Forecast

Year	Annual Crash Cost						Crash Benefit						Present Value Crash Benefit					
	Alternative 0 (No Build)	Alternative 1 All-Way Stop	Alternative 2 Modified Signal Timing	Alternative 2A Modified Signal Timing + RTLs	Alternative 3 Mini Roundabout	Alternative 4 Truck Route	Alternative 0 (No Build)	Alternative 1 All-Way Stop	Alternative 2 Modified Signal Timing	Alternative 2A Modified Signal Timing + RTLs	Alternative 3 Mini Roundabout	Alternative 4 Truck Route	Alternative 0 (No Build)	Alternative 1 All-Way Stop	Alternative 2 Modified Signal Timing	Alternative 2A Modified Signal Timing + RTLs	Alternative 3 Mini Roundabout	Alternative 4 Truck Route
2030	\$ 460,600	\$ 460,600	\$ 460,600	\$ 448,000	\$ 154,427	\$ 449,800	\$ -	\$ -	\$ -	\$ 12,600	\$ 306,173	\$ 10,800	\$ -	\$ -	\$ -	\$ 12,600	\$ 306,173	\$ 10,800
2031	\$ 463,658	\$ 463,658	\$ 463,658	\$ 450,975	\$ 155,236	\$ 452,787	\$ -	\$ -	\$ -	\$ 12,684	\$ 308,422	\$ 10,872	\$ -	\$ -	\$ -	\$ 12,302	\$ 299,149	\$ 10,545
2032	\$ 466,717	\$ 466,717	\$ 466,717	\$ 453,949	\$ 156,046	\$ 455,773	\$ -	\$ -	\$ -	\$ 12,767	\$ 310,671	\$ 10,943	\$ -	\$ -	\$ -	\$ 12,011	\$ 292,269	\$ 10,295
2033	\$ 469,775	\$ 469,775	\$ 469,775	\$ 456,924	\$ 156,855	\$ 458,760	\$ -	\$ -	\$ -	\$ 12,851	\$ 312,920	\$ 11,015	\$ -	\$ -	\$ -	\$ 11,726	\$ 285,534	\$ 10,051
2034	\$ 472,834	\$ 472,834	\$ 472,834	\$ 459,899	\$ 157,665	\$ 461,747	\$ -	\$ -	\$ -	\$ 12,935	\$ 315,169	\$ 11,087	\$ -	\$ -	\$ -	\$ 11,448	\$ 278,938	\$ 9,812
2035	\$ 475,892	\$ 475,892	\$ 475,892	\$ 462,874	\$ 158,474	\$ 464,733	\$ -	\$ -	\$ -	\$ 13,018	\$ 317,417	\$ 11,159	\$ -	\$ -	\$ -	\$ 11,175	\$ 272,482	\$ 9,579
2036	\$ 478,950	\$ 478,950	\$ 478,950	\$ 465,848	\$ 159,284	\$ 467,720	\$ -	\$ -	\$ -	\$ 13,102	\$ 319,666	\$ 11,230	\$ -	\$ -	\$ -	\$ 10,909	\$ 266,161	\$ 9,351
2037	\$ 482,009	\$ 482,009	\$ 482,009	\$ 468,823	\$ 160,094	\$ 470,707	\$ -	\$ -	\$ -	\$ 13,186	\$ 321,915	\$ 11,302	\$ -	\$ -	\$ -	\$ 10,649	\$ 259,974	\$ 9,127
2038	\$ 485,067	\$ 485,067	\$ 485,067	\$ 471,798	\$ 160,903	\$ 473,693	\$ -	\$ -	\$ -	\$ 13,269	\$ 324,164	\$ 11,374	\$ -	\$ -	\$ -	\$ 10,394	\$ 253,919	\$ 8,909
2039	\$ 488,125	\$ 488,125	\$ 488,125	\$ 474,772	\$ 161,713	\$ 476,680	\$ -	\$ -	\$ -	\$ 13,353	\$ 326,413	\$ 11,445	\$ -	\$ -	\$ -	\$ 10,145	\$ 247,993	\$ 8,696
2040	\$ 491,184	\$ 491,184	\$ 491,184	\$ 477,747	\$ 162,522	\$ 479,667	\$ -	\$ -	\$ -	\$ 13,437	\$ 328,662	\$ 11,517	\$ -	\$ -	\$ -	\$ 9,902	\$ 242,193	\$ 8,487
2041	\$ 494,242	\$ 494,242	\$ 494,242	\$ 480,722	\$ 163,332	\$ 482,653	\$ -	\$ -	\$ -	\$ 13,520	\$ 330,910	\$ 11,589	\$ -	\$ -	\$ -	\$ 9,664	\$ 236,518	\$ 8,283
2042	\$ 497,301	\$ 497,301	\$ 497,301	\$ 483,697	\$ 164,141	\$ 485,640	\$ -	\$ -	\$ -	\$ 13,604	\$ 333,159	\$ 11,661	\$ -	\$ -	\$ -	\$ 9,431	\$ 230,966	\$ 8,084
2043	\$ 500,359	\$ 500,359	\$ 500,359	\$ 486,671	\$ 164,951	\$ 488,627	\$ -	\$ -	\$ -	\$ 13,688	\$ 335,408	\$ 11,732	\$ -	\$ -	\$ -	\$ 9,204	\$ 225,533	\$ 7,889
2044	\$ 503,417	\$ 503,417	\$ 503,417	\$ 489,646	\$ 165,761	\$ 491,613	\$ -	\$ -	\$ -	\$ 13,771	\$ 337,657	\$ 11,804	\$ -	\$ -	\$ -	\$ 8,982	\$ 220,219	\$ 7,699
2045	\$ 506,476	\$ 506,476	\$ 506,476	\$ 492,621	\$ 166,570	\$ 494,600	\$ -	\$ -	\$ -	\$ 13,855	\$ 339,906	\$ 11,876	\$ -	\$ -	\$ -	\$ 8,764	\$ 215,020	\$ 7,512
2046	\$ 509,534	\$ 509,534	\$ 509,534	\$ 495,596	\$ 167,380	\$ 497,587	\$ -	\$ -	\$ -	\$ 13,939	\$ 342,155	\$ 11,947	\$ -	\$ -	\$ -	\$ 8,552	\$ 209,934	\$ 7,331
2047	\$ 512,593	\$ 512,593	\$ 512,593	\$ 498,570	\$ 168,189	\$ 500,573	\$ -	\$ -	\$ -	\$ 14,022	\$ 344,403	\$ 12,019	\$ -	\$ -	\$ -	\$ 8,345	\$ 204,960	\$ 7,153
2048	\$ 515,651	\$ 515,651	\$ 515,651	\$ 501,545	\$ 168,999	\$ 503,560	\$ -	\$ -	\$ -	\$ 14,106	\$ 346,652	\$ 12,091	\$ -	\$ -	\$ -	\$ 8,142	\$ 200,096	\$ 6,979
2049	\$ 518,709	\$ 518,709	\$ 518,709	\$ 504,520	\$ 169,808	\$ 506,547	\$ -	\$ -	\$ -	\$ 14,190	\$ 348,901	\$ 12,163	\$ -	\$ -	\$ -	\$ 7,944	\$ 195,338	\$ 6,809
2050	\$ 521,768	\$ 521,768	\$ 521,768	\$ 507,494	\$ 170,618	\$ 509,533	\$ -	\$ -	\$ -	\$ 14,273	\$ 351,150	\$ 12,234	\$ -	\$ -	\$ -	\$ 7,751	\$ 190,686	\$ 6,644
	\$ 10,314,861	\$ 10,314,861	\$ 10,314,861	\$ 10,032,691	\$ 3,412,968	\$ 10,073,001	\$ -	\$ -	\$ -	\$ 282,169	\$ 6,901,893	\$ 241,860	\$ -	\$ -	\$ -	\$ 210,040	\$ 5,134,058	\$ 180,034

Discount Rate 3.1%
 Construction Year 2030
 Design Year 2050

APPENDIX H: DETAILED COST ESTIMATES

**ENGINEER'S CONCEPTUAL OPINION OF PROBABLE COST
US 169 & MN 210 (W JCT.) - Mini Roundabout**

Date Prepared:
October 14, 2025

Item #	Description	Unit	Unit Price	Quantity	Total
Roadway Paving					
2104.502	Remove Signal System	EACH	\$20,000.00	1	\$20,000
2104.503	Remove Curb & Gutter	LIN FT	\$8.00	900	\$7,200
2104.507	Remove Bituminous Pavement	SQ YD	\$10.00	2800	\$28,000
2104.518	Remove Concrete Walk	SQ FT	\$3.00	7800	\$23,400
2106.507	Excavation - Common	CU YD	\$12.00	2100	\$25,200
2106.507	Common Embankment (CV)	CU YD	\$5.00	1100	\$5,500
2106.507	Select Granular Embankment (CV)	CU YD	\$25.00	1300	\$32,500
2211.507	Aggregate Base (CV) Class 6	CU YD	\$40.00	1000	\$40,000
2360.504	Type SP 12.5 Wearing Course Mix	TON	\$100.00	800	\$80,000
2521.518	6" Concrete Walk	SQ FT	\$15.00	10500	\$157,500
2531.503	Concrete Curb and Gutter	LIN FT	\$35.00	1400	\$49,000
2531.618	Truncated Domes	SQ FT	\$75.00	300	\$22,500
Subtotal Paving and Grading Costs					\$448,300
Drainage and Erosion					
	Drainage			10%	\$49,000
	Turf Establishment & Erosion Control			5%	\$25,000
Subtotal Drainage and Erosion Costs					\$74,000
Signing and Striping					
	Signing & Pavement Marking			6%	\$29,000
Subtotal Signing and Striping Costs					\$29,000
Temp Traffic Control / Mobilization / Staging					
	Temporary Pavement & Drainage			5%	\$25,000
2563.601	Traffic Control			7%	\$34,000
2021.501	Mobilization			10%	\$49,000
Subtotal Temp Traffic Control / Mobilization / Staging					\$108,000
Traffic Signals / Lighting / Maintenance					
	Lighting			15%	\$74,000
Subtotal Traffic Signals / Lighting / Maintenance					\$74,000
Indirect Costs & Contingency					
Construction Subtotal					\$775,800
30% Contingency					\$233,000
2025 Construction Cost Plus Contingency					\$1,008,800
2030 Inflation Adjustment Factor (Assume 5% Annually)				5%	
2030 Construction Cost Plus Contingency					\$1,287,513

Notes and Assumptions:

- Pavement Section is 7" Bit, 8" Agg Base Class 6, 15" Select Granular
- Concrete Median is 6" Concrete Walk, 14" Agg Base Class 6, 15" Select Granular
- Concrete Sidewalk is 6" Concrete Walk, 6" Agg Base Class 6
- Density of Bituminous to be 113 lb/sy*in
- Utility costs not included in estimate.
- All existing concrete walk within limits of Mini-RAB to be removed and replaced.
- R/W and Easement Costs not included in estimate.

APPENDIX I: TRUCK TURNING MOVEMENTS

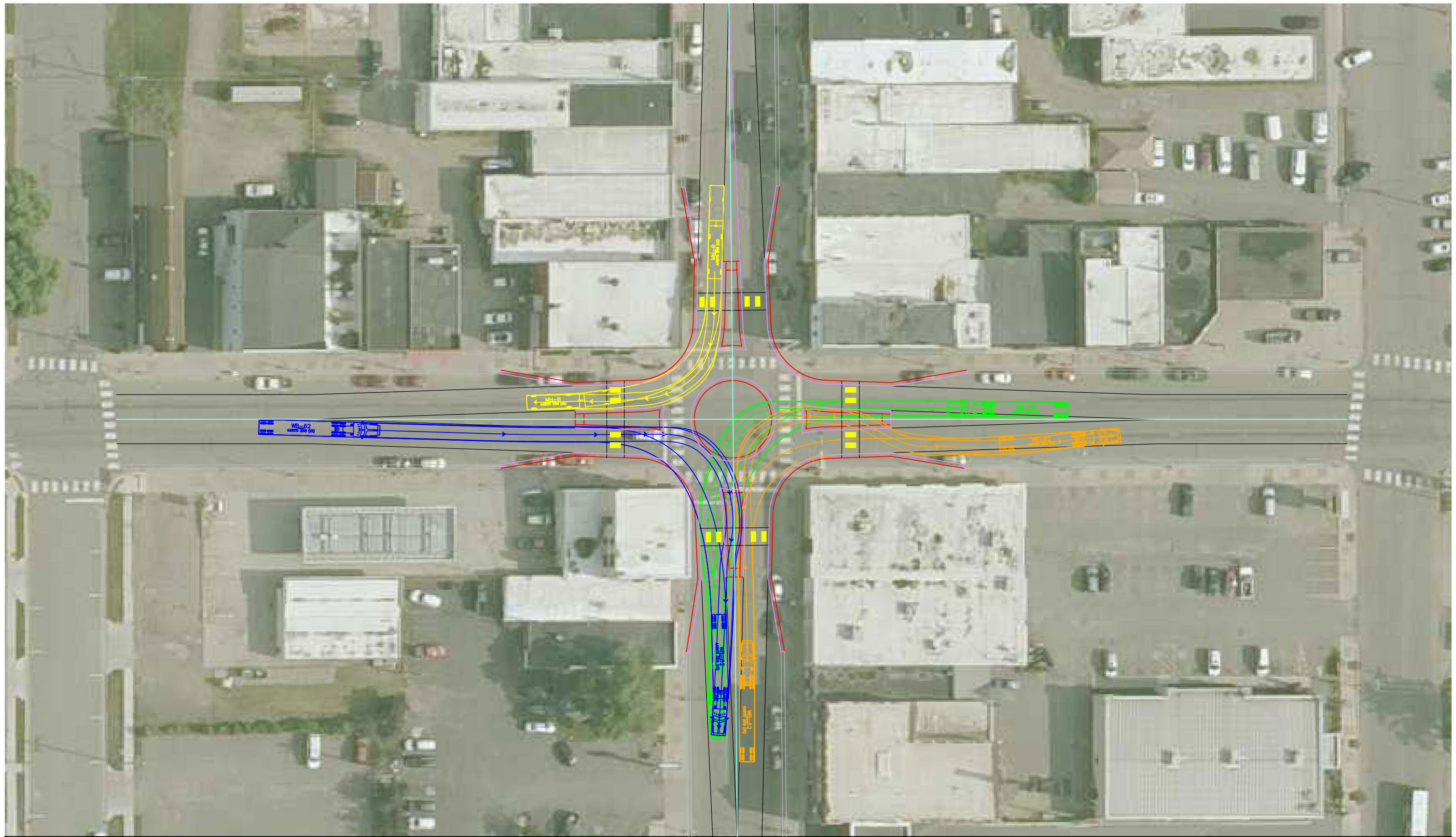

US 169 & MN 210 (W JCT) ICE

Appendix I
Truck Turning Movements



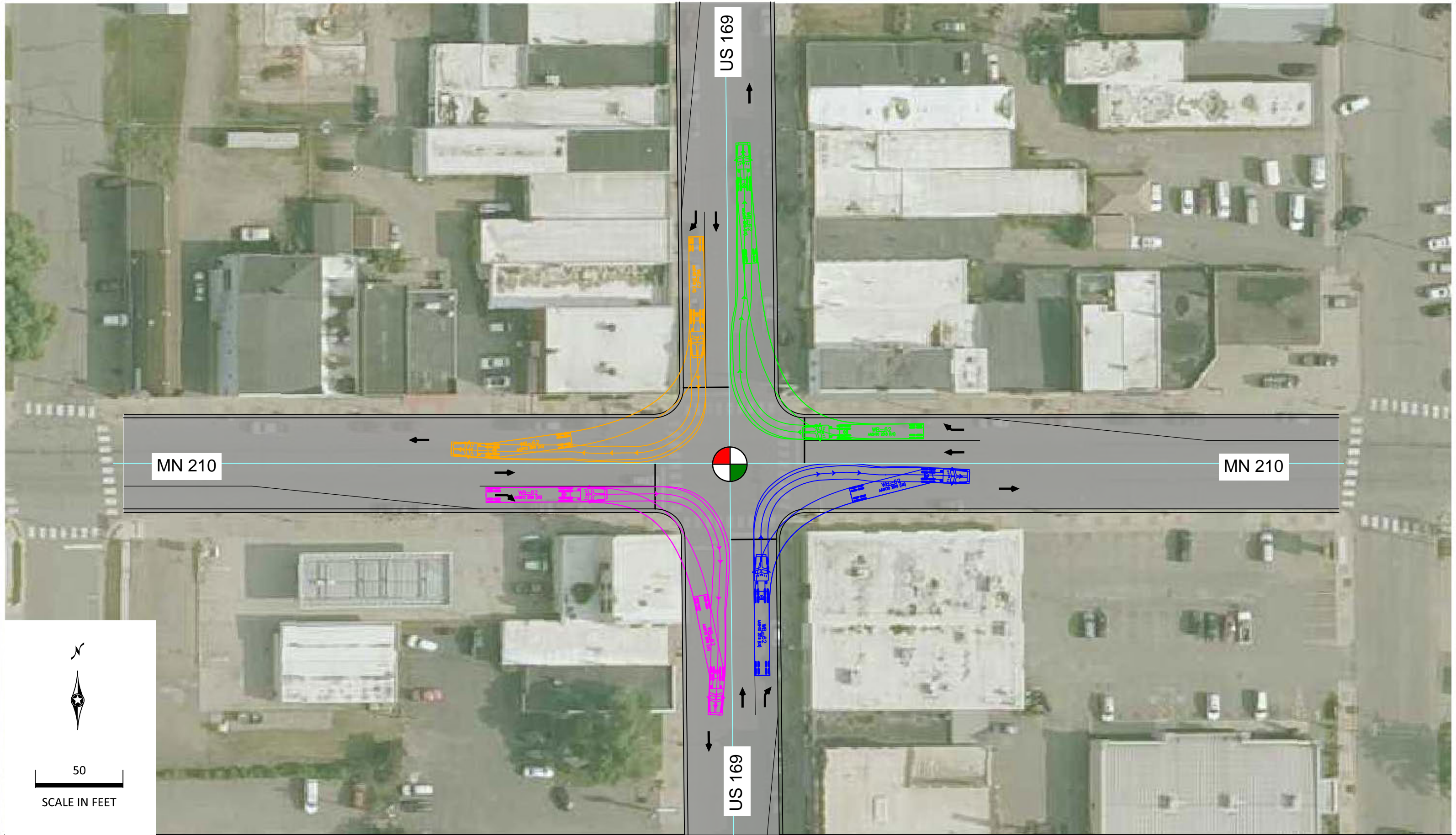

US 169 & MN 210 (W JCT) ICE

APPENDIX J: BENEFIT/COST ANALYSIS RESULTS

Daily and Annual Vehicle Hours Traveled (Weekday Peak Hours)

2030 Vehicle Hours Traveled (VHT) - Weekday Peak Hours

Time Period	Grouping	Percent of Grouping by Volume	2030 ALT 0 Total Delay (Veh-Hr)	2030 ALT 1 Total Delay (Veh-Hr)	2030 ALT 2 Total Delay (Veh-Hr)	2030 ALT 2A Total Delay (Veh-Hr)	2030 ALT 3 Total Delay (Veh-Hr)	2030 ALT 4 Total Delay (Veh-Hr)
12:00 AM	AM OFF	2.7%	0.22	0.17	0.24	0.20	0.02	0.22
1:00 AM	AM OFF	1.8%	0.15	0.11	0.16	0.14	0.01	0.14
2:00 AM	AM OFF	1.5%	0.13	0.09	0.14	0.12	0.01	0.12
3:00 AM	AM OFF	1.5%	0.13	0.09	0.14	0.12	0.01	0.12
4:00 AM	AM OFF	6.1%	0.51	0.39	0.56	0.47	0.04	0.50
5:00 AM	AM OFF	19.1%	1.61	1.21	1.76	1.47	0.14	1.55
6:00 AM	AM	39.5%	3.32	2.49	3.63	3.04	0.28	3.20
7:00 AM	AM	100.0%	8.40	6.30	9.20	7.70	0.72	8.10
8:00 AM	AM	87.4%	7.34	5.51	8.04	6.73	0.63	7.08
9:00 AM	OFF	88.7%	7.45	5.59	8.16	6.83	0.64	7.18
10:00 AM	OFF	95.4%	8.01	6.01	8.78	7.35	0.69	7.73
11:00 AM	OFF	96.5%	8.11	6.08	8.88	7.43	0.70	7.82
12:00 PM	OFF	89.3%	9.91	6.78	10.71	8.75	0.99	8.48
1:00 PM	OFF	82.3%	9.14	6.26	9.88	8.07	0.91	7.82
2:00 PM	OFF	83.0%	9.22	6.31	9.96	8.14	0.92	7.89
3:00 PM	PM	100.0%	11.10	7.60	12.00	9.80	1.11	9.50
4:00 PM	PM	98.8%	10.97	7.51	11.86	9.69	1.09	9.39
5:00 PM	PM	77.5%	8.60	5.89	9.30	7.60	0.86	7.36
6:00 PM	PM	54.8%	6.08	4.16	6.57	5.37	0.61	5.20
7:00 PM	PM OFF	40.9%	4.54	3.11	4.91	4.01	0.45	3.89
8:00 PM	PM OFF	27.4%	3.04	2.08	3.29	2.68	0.30	2.60
9:00 PM	PM OFF	22.2%	2.46	1.69	2.66	2.17	0.25	2.11
10:00 PM	PM OFF	10.2%	1.13	0.77	1.22	1.00	0.11	0.97
11:00 PM	PM OFF	3.9%	0.43	0.30	0.47	0.38	0.04	0.37
2030 Daily Vehicle Hours Traveled (VHT)			122.0	86.5	132.5	109.3	11.5	109.3
2030 Annual Vehicle Hours Traveled (VHT)			41390.8	29345.1	44964.7	37063.3	3913.4	37093.8

2050 Vehicle Hours Traveled (VHT) - Weekday Peak Hours

Time Period	Grouping	Percent of Grouping by Volume	2050 ALT 0 Total Delay (Veh-Hr)	2050 ALT 1 Total Delay (Veh-Hr)	2050 ALT 2 Total Delay (Veh-Hr)	2050 ALT 2A Total Delay (Veh-Hr)	2050 ALT 3 Total Delay (Veh-Hr)	2050 ALT 4 Total Delay (Veh-Hr)
12:00 AM	AM OFF	3.6%	0.59	0.50	0.66	0.46	0.04	0.40
1:00 AM	AM OFF	2.5%	0.40	0.34	0.45	0.31	0.03	0.27
2:00 AM	AM OFF	2.0%	0.32	0.27	0.36	0.25	0.02	0.22
3:00 AM	AM OFF	2.2%	0.36	0.31	0.41	0.29	0.03	0.25
4:00 AM	AM OFF	7.0%	1.13	0.96	1.27	0.88	0.08	0.77
5:00 AM	AM OFF	19.4%	3.15	2.68	3.54	2.47	0.22	2.14
6:00 AM	AM	39.8%	6.45	5.49	7.25	5.06	0.46	4.38
7:00 AM	AM	100.0%	16.20	13.80	18.20	12.70	1.15	11.00
8:00 AM	AM	87.5%	14.18	12.08	15.93	11.12	1.01	9.63
9:00 AM	OFF	88.0%	14.25	12.14	16.01	11.17	1.01	9.68
10:00 AM	OFF	95.3%	15.44	13.15	17.34	12.10	1.10	10.48
11:00 AM	OFF	95.9%	15.54	13.24	17.46	12.18	1.10	10.55
12:00 PM	OFF	89.4%	22.79	23.24	23.24	15.55	1.74	20.73
1:00 PM	OFF	82.1%	20.94	21.35	21.35	14.29	1.60	19.05
2:00 PM	OFF	83.3%	21.24	21.65	21.65	14.49	1.63	19.32
3:00 PM	PM	100.0%	25.50	26.00	26.00	17.40	1.95	23.20
4:00 PM	PM	99.1%	25.27	25.77	25.77	17.24	1.93	22.99
5:00 PM	PM	77.8%	19.83	20.22	20.22	13.53	1.52	18.04
6:00 PM	PM	55.0%	14.02	14.29	14.29	9.56	1.07	12.75
7:00 PM	PM OFF	41.1%	10.47	10.68	10.68	7.15	0.80	9.53
8:00 PM	PM OFF	27.7%	7.06	7.20	7.20	4.82	0.54	6.42
9:00 PM	PM OFF	22.3%	5.68	5.80	5.80	3.88	0.44	5.17
10:00 PM	PM OFF	10.6%	2.71	2.76	2.76	1.85	0.21	2.47
11:00 PM	PM OFF	4.7%	1.19	1.22	1.22	0.81	0.09	1.08
2050 Daily Vehicle Hours Traveled (VHT)			264.7	255.1	279.0	189.6	19.8	220.5
2050 Annual Vehicle Hours Traveled (VHT)			89801.1	86553.6	94662.2	64309.2	6704.9	74811.2

Daily and Annual Vehicle Hours Traveled (Friday Peak Hour)

2030 Vehicle Hours Traveled (VHT) - Friday Peak Hour

Time Period	Grouping	Percent of Grouping by Volume	2030 ALT 0 Total Delay (Veh-Hr)	2030 ALT 1 Total Delay (Veh-Hr)	2030 ALT 2 Total Delay (Veh-Hr)	2030 ALT 2A Total Delay (Veh-Hr)	2030 ALT 3 Total Delay (Veh-Hr)	2030 ALT 4 Total Delay (Veh-Hr)
12:00 AM	AM OFF	2.7%	0.23	0.17	0.25	0.21	0.02	0.22
1:00 AM	AM OFF	1.8%	0.15	0.11	0.17	0.14	0.01	0.15
2:00 AM	AM OFF	1.5%	0.13	0.10	0.14	0.12	0.01	0.12
3:00 AM	AM OFF	1.5%	0.13	0.10	0.14	0.12	0.01	0.12
4:00 AM	AM OFF	6.2%	0.52	0.39	0.57	0.48	0.04	0.50
5:00 AM	AM OFF	19.5%	1.64	1.23	1.79	1.50	0.14	1.58
6:00 AM	AM	44.7%	3.75	2.81	4.11	3.44	0.32	3.62
7:00 AM	AM	100.0%	8.40	6.30	9.20	7.70	0.71	8.10
8:00 AM	AM	109.9%	9.23	6.93	10.11	8.46	0.78	8.90
9:00 AM	OFF	108.5%	9.11	6.83	9.98	8.35	0.77	8.79
10:00 AM	OFF	82.4%	32.61	37.31	31.71	15.57	1.70	18.69
11:00 AM	OFF	84.7%	33.55	38.37	32.61	16.01	1.75	19.23
12:00 PM	OFF	92.6%	36.68	41.96	35.66	17.51	1.92	21.03
1:00 PM	OFF	92.1%	36.49	41.74	35.48	17.42	1.91	20.92
2:00 PM	OFF	88.3%	34.96	39.99	33.99	16.68	1.83	20.04
3:00 PM	PM	100.0%	39.60	45.30	38.50	18.90	2.07	22.70
4:00 PM	PM	94.9%	37.59	43.00	36.55	17.94	1.96	21.55
5:00 PM	PM	79.4%	31.44	35.97	30.57	15.01	1.64	18.02
6:00 PM	PM	92.3%	7.76	5.82	8.49	7.11	0.65	7.48
7:00 PM	PM OFF	47.5%	3.99	2.99	4.37	3.66	0.34	3.85
8:00 PM	PM OFF	31.8%	2.67	2.00	2.92	2.45	0.22	2.57
9:00 PM	PM OFF	25.7%	2.16	1.62	2.37	1.98	0.18	2.08
10:00 PM	PM OFF	11.8%	0.99	0.74	1.09	0.91	0.08	0.96
11:00 PM	PM OFF	4.5%	0.38	0.28	0.42	0.35	0.03	0.37
2030 Daily Vehicle Hours Traveled (VHT)			334.2	362.1	331.2	182.0	19.1	211.6
2030 Annual Vehicle Hours Traveled (VHT)			4344.1	4706.9	4305.4	2366.0	248.3	2750.7

2050 Vehicle Hours Traveled (VHT) - Friday Peak Hour

Time Period	Grouping	Percent of Grouping by Volume	2050 ALT 0 Total Delay (Veh-Hr)	2050 ALT 1 Total Delay (Veh-Hr)	2050 ALT 2 Total Delay (Veh-Hr)	2050 ALT 2A Total Delay (Veh-Hr)	2050 ALT 3 Total Delay (Veh-Hr)	2050 ALT 4 Total Delay (Veh-Hr)
12:00 AM	AM OFF	3.7%	0.60	0.51	0.67	0.47	0.04	0.41
1:00 AM	AM OFF	2.5%	0.41	0.35	0.46	0.32	0.03	0.28
2:00 AM	AM OFF	2.0%	0.32	0.28	0.36	0.25	0.02	0.22
3:00 AM	AM OFF	2.3%	0.37	0.32	0.42	0.29	0.03	0.25
4:00 AM	AM OFF	7.1%	1.15	0.98	1.29	0.90	0.08	0.78
5:00 AM	AM OFF	19.8%	3.21	2.74	3.61	2.52	0.22	2.18
6:00 AM	AM	44.7%	7.24	6.17	8.13	5.67	0.50	4.91
7:00 AM	AM	100.0%	16.20	13.80	18.20	12.70	1.13	11.00
8:00 AM	AM	110.0%	17.82	15.18	20.02	13.97	1.24	12.10
9:00 AM	OFF	108.4%	17.55	14.95	19.72	13.76	1.22	11.92
10:00 AM	OFF	82.1%	182.52	192.13	174.65	93.23	3.50	124.01
11:00 AM	OFF	84.7%	188.47	198.39	180.34	96.27	3.61	128.05
12:00 PM	OFF	92.4%	205.44	216.24	196.57	104.94	3.94	139.57
1:00 PM	OFF	92.2%	205.11	215.90	196.25	104.77	3.93	139.35
2:00 PM	OFF	88.1%	195.96	206.27	187.50	100.10	3.76	133.14
3:00 PM	PM	100.0%	222.40	234.10	212.80	113.60	4.26	151.10
4:00 PM	PM	94.8%	210.94	222.04	201.84	107.75	4.04	143.32
5:00 PM	PM	79.3%	176.36	185.63	168.74	90.08	3.38	119.82
6:00 PM	PM	92.7%	15.01	12.79	16.87	11.77	1.04	10.19
7:00 PM	PM OFF	47.4%	7.68	6.54	8.63	6.02	0.53	5.22
8:00 PM	PM OFF	32.0%	5.18	4.41	5.82	4.06	0.36	3.51
9:00 PM	PM OFF	25.7%	4.17	3.55	4.68	3.27	0.29	2.83
10:00 PM	PM OFF	12.3%	1.99	1.69	2.23	1.56	0.14	1.35
11:00 PM	PM OFF	5.4%	0.87	0.75	0.98	0.69	0.06	0.59
2050 Daily Vehicle Hours Traveled (VHT)			1687.0	1755.7	1630.8	888.9	37.4	1146.1
2050 Annual Vehicle Hours Traveled (VHT)			21930.7	22824.1	21200.2	11556.3	485.7	14899.4

Daily and Annual Vehicle Hours Traveled (Sunday Peak Hour)

2030 Vehicle Hours Traveled (VHT) - Sunday Peak Hour

Time Period	Grouping	Percent of Grouping by Volume	2030 ALT 0 Total Delay (Veh-Hr)	2030 ALT 1 Total Delay (Veh-Hr)	2030 ALT 2 Total Delay (Veh-Hr)	2030 ALT 2A Total Delay (Veh-Hr)	2030 ALT 3 Total Delay (Veh-Hr)	2030 ALT 4 Total Delay (Veh-Hr)
12:00 AM	AM OFF	2.1%	0.38	0.28	0.39	0.26	0.02	0.37
1:00 AM	AM OFF	1.4%	0.25	0.19	0.26	0.18	0.01	0.25
2:00 AM	AM OFF	1.2%	0.21	0.16	0.22	0.15	0.01	0.21
3:00 AM	AM OFF	1.2%	0.21	0.16	0.22	0.15	0.01	0.21
4:00 AM	AM OFF	4.9%	0.87	0.64	0.89	0.60	0.04	0.85
5:00 AM	AM OFF	15.4%	2.72	2.00	2.78	1.89	0.14	2.65
6:00 AM	AM	10.3%	1.82	1.33	1.86	1.26	0.09	1.76
7:00 AM	AM	28.9%	5.12	3.76	5.23	3.56	0.26	4.97
8:00 AM	AM	46.7%	8.27	6.07	8.46	5.75	0.42	8.04
9:00 AM	OFF	66.0%	11.67	8.57	11.94	8.11	0.59	11.34
10:00 AM	OFF	91.4%	16.17	11.88	16.54	11.24	0.81	15.72
11:00 AM	OFF	98.0%	17.35	12.74	17.74	12.05	0.87	16.86
12:00 PM	OFF	100.0%	17.70	13.00	18.10	12.30	0.89	17.20
1:00 PM	OFF	87.7%	15.52	11.40	15.87	10.78	0.78	15.08
2:00 PM	OFF	76.8%	13.59	9.98	13.90	9.44	0.68	13.21
3:00 PM	PM	71.4%	12.63	9.28	12.92	8.78	0.64	12.28
4:00 PM	PM	62.7%	11.11	8.16	11.36	7.72	0.56	10.79
5:00 PM	PM	62.2%	11.01	8.08	11.25	7.65	0.55	10.69
6:00 PM	PM	49.6%	8.77	6.44	8.97	6.10	0.44	8.53
7:00 PM	PM OFF	37.5%	6.63	4.87	6.78	4.61	0.33	6.44
8:00 PM	PM OFF	25.1%	4.44	3.26	4.54	3.08	0.22	4.31
9:00 PM	PM OFF	20.3%	3.59	2.64	3.67	2.50	0.18	3.49
10:00 PM	PM OFF	9.3%	1.65	1.21	1.69	1.15	0.08	1.60
11:00 PM	PM OFF	3.6%	0.63	0.46	0.64	0.44	0.03	0.61
2030 Daily Vehicle Hours Traveled (VHT)			172.3	126.6	176.2	119.7	8.7	167.5
2030 Annual Vehicle Hours Traveled (VHT)			2240.2	1645.3	2290.8	1556.7	112.7	2176.9

2050 Vehicle Hours Traveled (VHT) - Sunday Peak Hour

Time Period	Grouping	Percent of Grouping by Volume	2050 ALT 0 Total Delay (Veh-Hr)	2050 ALT 1 Total Delay (Veh-Hr)	2050 ALT 2 Total Delay (Veh-Hr)	2050 ALT 2A Total Delay (Veh-Hr)	2050 ALT 3 Total Delay (Veh-Hr)	2050 ALT 4 Total Delay (Veh-Hr)
12:00 AM	AM OFF	2.9%	3.19	2.68	2.69	0.85	0.05	2.88
1:00 AM	AM OFF	2.0%	2.17	1.82	1.83	0.58	0.03	1.96
2:00 AM	AM OFF	1.6%	1.72	1.45	1.45	0.46	0.03	1.55
3:00 AM	AM OFF	1.8%	1.98	1.66	1.67	0.52	0.03	1.78
4:00 AM	AM OFF	5.6%	6.13	5.15	5.17	1.63	0.10	5.52
5:00 AM	AM OFF	15.6%	17.12	14.38	14.42	4.54	0.27	15.41
6:00 AM	AM	10.8%	11.81	9.92	9.96	3.13	0.18	10.64
7:00 AM	AM	29.3%	32.06	26.93	27.02	8.50	0.50	28.87
8:00 AM	AM	47.1%	51.47	43.24	43.38	13.65	0.80	46.35
9:00 AM	OFF	66.3%	72.55	60.94	61.14	19.23	1.13	65.32
10:00 AM	OFF	91.5%	100.14	84.12	84.40	26.55	1.56	90.16
11:00 AM	OFF	97.8%	107.04	89.92	90.21	28.37	1.67	96.37
12:00 PM	OFF	100.0%	109.40	91.90	92.20	29.00	1.70	98.50
1:00 PM	OFF	88.1%	96.37	80.96	81.22	25.55	1.50	86.77
2:00 PM	OFF	76.4%	83.53	70.17	70.40	22.14	1.30	75.21
3:00 PM	PM	71.6%	78.36	65.83	66.04	20.77	1.22	70.55
4:00 PM	PM	63.2%	69.17	58.10	58.29	18.33	1.08	62.27
5:00 PM	PM	62.5%	68.34	57.40	57.59	18.11	1.06	61.53
6:00 PM	PM	49.6%	54.22	45.55	45.70	14.37	0.84	48.82
7:00 PM	PM OFF	37.4%	40.94	34.39	34.50	10.85	0.64	36.86
8:00 PM	PM OFF	25.2%	27.59	23.18	23.25	7.31	0.43	24.84
9:00 PM	PM OFF	20.3%	22.22	18.67	18.73	5.89	0.35	20.01
10:00 PM	PM OFF	9.7%	10.60	8.91	8.93	2.81	0.17	9.55
11:00 PM	PM OFF	4.3%	4.66	3.92	3.93	1.24	0.07	4.20
2050 Daily Vehicle Hours Traveled (VHT)			1072.8	901.2	904.1	284.4	16.7	965.9
2050 Annual Vehicle Hours Traveled (VHT)			13946.4	11715.5	11753.7	3696.9	217.2	12556.8

US 169 & MN 210 (W JCT) --- Benefit / Cost Analysis for Alternative 1 All-Way Stop 2050 Forecast

BASE 2030	Total
DELAY (Stop)	47,975

2050 No Improvement	Total	2030 No Improvement	Total
DELAY (Stop)	125,678	DELAY (Stop)	47,975

2050 Improvement	Total	2030 Improvement	Total
DELAY (Alt)	121,093	DELAY (Alt)	35,697

2050 Changes:	Total
DELAY	(4,585) -3.6%

Category	COST ITEM				
	1	2	3	4	5
Capital Value (\$)	-	\$0	\$0	-	\$0
Remaining Life (%) - 20yr	44%	84%	27%	44%	96%
Remaining Cap. Value	\$ -	\$ -	\$ -	\$ -	\$ -

Note: Assume Expected Life of 30 Years. Analysis Period is 20 years.

B/C Analysis Summary	
BENEFITS Value(Discounted)	
1. Travel Time Savings:	\$ 5,521,373
TOTAL	\$ 5,521,373

COSTS Value(Discounted)	
1. Roadway/Interchange	\$ -
2. Bridges	\$ -
3. Maintenance	\$ (2,948)
4. Contingency Costs	\$ -
5. Right-of-way (ROW)	\$ -
Remaining Capital	\$ -
TOTAL	\$ (2,948)

Benefit/Cost Analysis Results	
20-Yr Operation Benefit	\$ 5,521,373
20-Yr Safety Benefit	\$ -
COSTS	\$ 10,000
B/C Ratio:	552.137

Cost Category	Improvement Description	Estimated NA	Estimated NA	Estimated NA
1	Roadway Paving	\$0	\$0	\$0
1	Drainage and Erosion	\$0	\$0	\$0
1	Misc	\$0	\$0	\$0
2	Bridge	\$0	\$0	\$0
2				
3	Traffic Signal/Lighting	\$0	\$0	\$0
3				
3				
Total Estimated Construction Costs		\$0	\$0	\$0
4	Indirect Costs & Contingency	\$0	\$0	\$0
5	Right-of-Way/Easement Costs	\$0	\$0	\$0
4	Professional Services	\$0	\$0	\$0
Total Project Costs		\$0	\$0	\$0

YEAR	Annual VHT		Annualized Savings		Discounted Value (3.1%)
	2050 No Improvement	2050 Improvement	Improvement w/ VHT Savings	'00 cost per hour 26.00	
2030	47,975	35,697	12,278	\$ 533,060.92	\$ 533,060.92
2031	51,860	39,967	11,893	\$ 516,361.37	\$ 500,835.47
2032	55,745	44,237	11,508	\$ 499,661.83	\$ 470,066.00
2033	59,631	48,507	11,124	\$ 482,962.28	\$ 440,694.08
2034	63,516	52,777	10,739	\$ 466,262.74	\$ 412,663.49
2035	67,401	57,046	10,354	\$ 449,563.20	\$ 385,920.12
2036	71,286	61,316	9,970	\$ 432,863.65	\$ 360,411.90
2037	75,171	65,586	9,585	\$ 416,164.11	\$ 336,088.74
2038	79,056	69,856	9,201	\$ 399,464.56	\$ 312,902.43
2039	82,941	74,125	8,816	\$ 382,765.02	\$ 290,806.60
2040	86,827	78,395	8,431	\$ 366,065.48	\$ 269,756.63
2041	90,712	82,665	8,047	\$ 349,365.93	\$ 249,709.60
2042	94,597	86,935	7,662	\$ 332,666.39	\$ 230,624.23
2043	98,482	91,205	7,277	\$ 315,966.84	\$ 212,460.83
2044	102,367	95,474	6,893	\$ 299,267.30	\$ 195,181.19
2045	106,252	99,744	6,508	\$ 282,567.76	\$ 178,748.59
2046	110,138	104,014	6,124	\$ 265,868.21	\$ 163,127.72
2047	114,023	108,284	5,739	\$ 249,168.67	\$ 148,284.62
2048	117,908	112,554	5,354	\$ 232,469.13	\$ 134,186.65
2049	121,793	116,823	4,970	\$ 215,769.58	\$ 120,802.40
2050	125,678	121,093	4,585	\$ 199,070.04	\$ 108,101.72
TOTAL				\$ 7,154,314	\$ 5,521,373

COST 1: Roadways/Interchange Construction		
YEAR	CHANGE with Improvement	Discounted Value (3.1%)
2030	\$ -	\$ -
2031	\$ -	\$ -
2032	\$ -	\$ -
2033	\$ -	\$ -
2034	\$ -	\$ -
2035	\$ -	\$ -
2036	\$ -	\$ -
2037	\$ -	\$ -
2038	\$ -	\$ -
2039	\$ -	\$ -
2040	\$ -	\$ -
2041	\$ -	\$ -
2042	\$ -	\$ -
2043	\$ -	\$ -
2044	\$ -	\$ -
2045	\$ -	\$ -
2046	\$ -	\$ -
2047	\$ -	\$ -
2048	\$ -	\$ -
2049	\$ -	\$ -
2050	\$ -	\$ -
TOTAL	\$ -	\$ -

COST 2: Bridge		
YEAR	CHANGE with Improvement	Discounted Value (3.1%)
2030	\$ -	\$ -
2031	\$ -	\$ -
2032	\$ -	\$ -
2033	\$ -	\$ -
2034	\$ -	\$ -
2035	\$ -	\$ -
2036	\$ -	\$ -
2037	\$ -	\$ -
2038	\$ -	\$ -
2039	\$ -	\$ -
2040	\$ -	\$ -
2041	\$ -	\$ -
2042	\$ -	\$ -
2043	\$ -	\$ -
2044	\$ -	\$ -
2045	\$ -	\$ -
2046	\$ -	\$ -
2047	\$ -	\$ -
2048	\$ -	\$ -
2049	\$ -	\$ -
2050	\$ -	\$ -
TOTAL	\$ -	\$ -

Note: Trucks on average account for approximately 6% of network traffic. Passenger vehicle occupancy assumed to be 1.68.

MnDOT Office of Investment Management, Benefit Cost Analysis Trucks (Value of Time) \$ 39.30

Standard Values, Appendix A, Fiscal Year 2022

COST 3: Maintenance & Operation			COST 4: Contingency Construction Costs			COST 5: Right of Way (ROW)		
YEAR	CHANGE with Improvement	Discounted Value (3.1%)	YEAR	CHANGE with Improvement	Discounted Value (3.1%)	YEAR	CHANGE with Improvement	Discounted Value (3.1%)
2030	\$ -	\$ -	2030	\$ -	\$ -	2030	\$ -	\$ -
2031	\$ (200)	\$ (194)	2031	\$ -	\$ -	2031	\$ -	\$ -
2032	\$ (200)	\$ (188)	2032	\$ -	\$ -	2032	\$ -	\$ -
2033	\$ (200)	\$ (182)	2033	\$ -	\$ -	2033	\$ -	\$ -
2034	\$ (200)	\$ (177)	2034	\$ -	\$ -	2034	\$ -	\$ -
2035	\$ (200)	\$ (172)	2035	\$ -	\$ -	2035	\$ -	\$ -
2036	\$ (200)	\$ (167)	2036	\$ -	\$ -	2036	\$ -	\$ -
2037	\$ (200)	\$ (162)	2037	\$ -	\$ -	2037	\$ -	\$ -
2038	\$ (200)	\$ (157)	2038	\$ -	\$ -	2038	\$ -	\$ -
2039	\$ (200)	\$ (152)	2039	\$ -	\$ -	2039	\$ -	\$ -
2040	\$ (200)	\$ (147)	2040	\$ -	\$ -	2040	\$ -	\$ -
2041	\$ (200)	\$ (143)	2041	\$ -	\$ -	2041	\$ -	\$ -
2042	\$ (200)	\$ (139)	2042	\$ -	\$ -	2042	\$ -	\$ -
2043	\$ (200)	\$ (134)	2043	\$ -	\$ -	2043	\$ -	\$ -
2044	\$ (200)	\$ (130)	2044	\$ -	\$ -	2044	\$ -	\$ -
2045	\$ (200)	\$ (127)	2045	\$ -	\$ -	2045	\$ -	\$ -
2046	\$ (200)	\$ (123)	2046	\$ -	\$ -	2046	\$ -	\$ -
2047	\$ (200)	\$ (119)	2047	\$ -	\$ -	2047	\$ -	\$ -
2048	\$ (200)	\$ (115)	2048	\$ -	\$ -	2048	\$ -	\$ -
2049	\$ (200)	\$ (112)	2049	\$ -	\$ -	2049	\$ -	\$ -
2050	\$ (200)	\$ (109)	2050	\$ -	\$ -	2050	\$ -	\$ -
TOTAL	\$ (4,000)	\$ (2,948)	TOTAL	\$ -	\$ -	TOTAL	\$ -	\$ -

Note: Assume maintenance and operation costs of the to be -200 per year.

Remaining Capital Value		
YEAR	Remaining Capital Value	Discounted Value (3.1%)
2030	\$ -	\$ -
2031	\$ -	\$ -
2032	\$ -	\$ -
2033	\$ -	\$ -
2034	\$ -	\$ -
2035	\$ -	\$ -
2036	\$ -	\$ -
2037	\$ -	\$ -
2038	\$ -	\$ -
2039	\$ -	\$ -
2040	\$ -	\$ -
2041	\$ -	\$ -
2042	\$ -	\$ -
2043	\$ -	\$ -
2044	\$ -	\$ -
2045	\$ -	\$ -
2046	\$ -	\$ -
2047	\$ -	\$ -
2048	\$ -	\$ -
2049	\$ -	\$ -
2050	\$ -	\$ -
TOTAL	\$ -	\$ -

US 169 & MN 210 (W JCT) --- Benefit / Cost Analysis for Alternative 2 Modified Signal Timing 2050 Forecast

BASE 2030	Total
DELAY (Stop)	47,975

2050 No Improvement	Total	2030 No Improvement	Total
DELAY (Stop)	125,678	DELAY (Stop)	47,975

2050 Improvement	Total	2030 Improvement	Total
DELAY (Alt)	127,616	DELAY (Alt)	51,561

2050 Changes:	Total
DELAY	1,938 1.5%

Category	COST ITEM				
	1 Roadway	2 Bridge	3 Traffic Signal/Lighting	4 Contingency Construction Costs	5 ROW
Capital Value (\$)	-	\$0	\$0	-	\$0
Remaining Life (%)-20yr	44%	84%	27%	44%	96%
Remaining Cap. Value	\$ -	\$ -	\$ -	\$ -	\$ -

Note: Assume Expected Life of 30 Years. Analysis Period is 20 years.

B/C Analysis Summary	
BENEFITS	Value(Discounted)
1. Travel Time Savings:	\$ (2,055,889)
TOTAL	\$ (2,055,889)

COSTS		Value(Discounted)
1. Roadway/Interchange	\$	-
2. Bridges	\$	-
3. Maintenance	\$	(38,169)
4. Contingency Costs	\$	-
5. Right-of-way (ROW)	\$	-
Remaining Capital	\$	-
TOTAL	\$	(38,169)

Benefit/Cost Analysis Results	
20-Yr Operation Benefit	\$ (2,055,889)
20-Yr Safety Benefit	\$ -
COSTS	\$ 500,000
B/C Ratio*	-4.112

Category	Improvement Description	Estimated NA	Estimated NA	Estimated NA
1	Roadway Paving	\$0	\$0	\$0
1	Drainage and Erosion	\$0	\$0	\$0
1	Misc	\$0	\$0	\$0
2	Bridge	\$0	\$0	\$0
2				
3	Traffic Signal/Lighting	\$0	\$0	\$0
3				
3				
Total Estimated Construction Costs		\$0	\$0	\$0
4	Indirect Costs & Contingency	\$0	\$0	\$0
5	Right-of-Way/Easement Costs	\$0	\$0	\$0
4	Professional Services	\$0	\$0	\$0
Total Project Costs		\$0	\$0	\$0

YEAR	Annual VHT		Annualized Savings		Discounted Value (3.1%)
	2050 No Improvement	2050 Improvement	Improvement w/ VHT Savings	'00 cost per hour 26.00	
2030	47,975	51,561	-3586	155,687.63	155,687.63
2031	51,675	55,183	-3507	152,280.67	147,701.91
2032	55,375	58,804	-3429	148,873.72	140,055.67
2033	59,076	62,426	-3350	145,466.77	132,735.71
2034	62,776	66,048	-3272	142,059.81	125,729.32
2035	66,476	69,669	-3194	138,652.86	119,024.26
2036	70,176	73,291	-3115	135,245.90	112,608.75
2037	73,876	76,913	-3037	131,838.95	106,471.43
2038	77,576	80,534	-2958	128,432.00	100,601.37
2039	81,276	84,156	-2880	125,025.04	94,988.06
2040	84,977	87,778	-2801	121,618.09	89,621.36
2041	88,677	91,399	-2723	118,211.13	84,491.51
2042	92,377	95,021	-2644	114,804.18	79,589.12
2043	96,077	98,643	-2566	111,397.23	74,905.16
2044	99,777	102,264	-2487	107,990.27	70,430.91
2045	103,477	105,886	-2409	104,583.32	66,158.01
2046	107,177	109,508	-2330	101,176.37	62,078.39
2047	110,878	113,129	-2252	97,769.41	58,184.28
2048	114,578	116,751	-2173	94,362.46	54,468.23
2049	118,278	120,373	-2094	90,955.51	50,928.17
2050	121,978	124,000	-2015	87,548.56	47,559.10
2051	125,678	127,626	-1936	84,141.60	44,317.86
TOTAL				(2,706,261)	(2,055,889)

COST 1: Roadways/Interchange Construction		
YEAR	CHANGE with Improvement	Discounted Value (3.1%)
2030	\$ -	\$ -
2031	\$ -	\$ -
2032	\$ -	\$ -
2033	\$ -	\$ -
2034	\$ -	\$ -
2035	\$ -	\$ -
2036	\$ -	\$ -
2037	\$ -	\$ -
2038	\$ -	\$ -
2039	\$ -	\$ -
2040	\$ -	\$ -
2041	\$ -	\$ -
2042	\$ -	\$ -
2043	\$ -	\$ -
2044	\$ -	\$ -
2045	\$ -	\$ -
2046	\$ -	\$ -
2047	\$ -	\$ -
2048	\$ -	\$ -
2049	\$ -	\$ -
2050	\$ -	\$ -
2051	\$ -	\$ -
TOTAL	\$ -	\$ -

COST 2: Bridge		
YEAR	CHANGE with Improvement	Discounted Value (3.1%)
2030	\$ -	\$ -
2031	\$ -	\$ -
2032	\$ -	\$ -
2033	\$ -	\$ -
2034	\$ -	\$ -
2035	\$ -	\$ -
2036	\$ -	\$ -
2037	\$ -	\$ -
2038	\$ -	\$ -
2039	\$ -	\$ -
2040	\$ -	\$ -
2041	\$ -	\$ -
2042	\$ -	\$ -
2043	\$ -	\$ -
2044	\$ -	\$ -
2045	\$ -	\$ -
2046	\$ -	\$ -
2047	\$ -	\$ -
2048	\$ -	\$ -
2049	\$ -	\$ -
2050	\$ -	\$ -
2051	\$ -	\$ -
TOTAL	\$ -	\$ -

Note: Trucks on average account for approximately 6% of network traffic. Passenger vehicle occupancy assumed to be 1.68.

MnDOT Office of Investment Management, Benefit Cost Analysis Trucks (Value of Time) \$ 39.30

Standard Values, Appendix A, Fiscal Year 2022

COST 3: Maintenance & Operation			COST 4: Contingency Construction Costs			COST 5: Right of Way (ROW)		
YEAR	CHANGE with Improvement	Discounted Value (3.1%)	YEAR	CHANGE with Improvement	Discounted Value (3.1%)	YEAR	CHANGE with Improvement	Discounted Value (3.1%)
2030	\$ -	\$ -	2030	\$ -	\$ -	2030	\$ -	\$ -
2031	\$ (2,500)	\$ (2,425)	2031	\$ -	\$ -	2031	\$ -	\$ -
2032	\$ (2,500)	\$ (2,352)	2032	\$ -	\$ -	2032	\$ -	\$ -
2033	\$ (2,500)	\$ (2,281)	2033	\$ -	\$ -	2033	\$ -	\$ -
2034	\$ (2,500)	\$ (2,213)	2034	\$ -	\$ -	2034	\$ -	\$ -
2035	\$ (2,500)	\$ (2,146)	2035	\$ -	\$ -	2035	\$ -	\$ -
2036	\$ (2,500)	\$ (2,082)	2036	\$ -	\$ -	2036	\$ -	\$ -
2037	\$ (2,500)	\$ (2,019)	2037	\$ -	\$ -	2037	\$ -	\$ -
2038	\$ (2,500)	\$ (1,958)	2038	\$ -	\$ -	2038	\$ -	\$ -
2039	\$ (2,500)	\$ (1,899)	2039	\$ -	\$ -	2039	\$ -	\$ -
2040	\$ (2,500)	\$ (1,842)	2040	\$ -	\$ -	2040	\$ -	\$ -
2041	\$ (2,500)	\$ (1,787)	2041	\$ -	\$ -	2041	\$ -	\$ -
2042	\$ (2,500)	\$ (1,733)	2042	\$ -	\$ -	2042	\$ -	\$ -
2043	\$ (2,500)	\$ (1,681)	2043	\$ -	\$ -	2043	\$ -	\$ -
2044	\$ (2,500)	\$ (1,630)	2044	\$ -	\$ -	2044	\$ -	\$ -
2045	\$ (2,500)	\$ (1,581)	2045	\$ -	\$ -	2045	\$ -	\$ -
2046	\$ (2,500)	\$ (1,534)	2046	\$ -	\$ -	2046	\$ -	\$ -
2047	\$ (2,500)	\$ (1,488)	2047	\$ -	\$ -	2047	\$ -	\$ -
2048	\$ (2,500)	\$ (1,443)	2048	\$ -	\$ -	2048	\$ -	\$ -
2049	\$ (2,500)	\$ (1,400)	2049	\$ -	\$ -	2049	\$ -	\$ -
2050	\$ (2,500)	\$ (1,358)	2050	\$ -	\$ -	2050	\$ -	\$ -
2051	\$ (2,500)	\$ (1,317)	2051	\$ -	\$ -	2051	\$ -	\$ -
TOTAL	\$ (62,500)	\$ (38,169)	TOTAL	\$ -	\$ -	TOTAL	\$ -	\$ -

Note: Assume maintenance and operation costs of the Traffic Signal to be -2500 per year.

Remaining Capital Value		
YEAR	Remaining Capital Value	Discounted Value (3.1%)
2030	\$ -	\$ -
2031	\$ -	\$ -
2032	\$ -	\$ -
2033	\$ -	\$ -
2034	\$ -	\$ -
2035	\$ -	\$ -
2036	\$ -	\$ -
2037	\$ -	\$ -
2038	\$ -	\$ -
2039	\$ -	\$ -
2040	\$ -	\$ -
2041	\$ -	\$ -
2042	\$ -	\$ -
2043	\$ -	\$ -
2044	\$ -	\$ -
2045	\$ -	\$ -
2046	\$ -	\$ -
2047	\$ -	\$ -
2048	\$ -	\$ -
2049	\$ -	\$ -
2050	\$ -	\$ -
2051	\$ -	\$ -
TOTAL	\$ -	\$ -

US 169 & MN 210 (W JCT) --- Benefit / Cost Analysis for Alternative 2A Modified Signal Timing + RTLs 2050 Forecast

BASE 2030	Total
DELAY (Stop)	47,975

2050 No Improvement	Total	2030 No Improvement	Total
DELAY (Stop)	125,678	DELAY (Stop)	47,975

2050 Improvement	Total	2030 Improvement	Total
DELAY (Alt)	79,562	DELAY (Alt)	40,986

2050 Changes:	Total
DELAY	(46,116) -36.7%

B/C Analysis Summary	
BENEFITS Value(Discounted)	
1. Travel Time Savings:	\$ 16,256,551
TOTAL	\$ 16,256,551

COSTS Value(Discounted)	
1. Roadway/Interchange	\$ -
2. Bridges	\$ -
3. Maintenance	\$ (638,169)
4. Contingency Costs	\$ -
5. Right-of-way (ROW)	\$ -
Remaining Capital	\$ -
TOTAL	\$ (638,169)

Benefit/Cost Analysis Results	
20-Yr Operation Benefit	\$ 16,256,551
20-Yr Safety Benefit	\$ 210,040
COSTS	\$ 600,000
B/C Ratio*	27.444

Category	Improvement Description	Estimated NA	Estimated NA	Estimated NA
1	Roadway Paving	\$0	\$0	\$0
1	Drainage and Erosion	\$0	\$0	\$0
1	Misc	\$0	\$0	\$0
2	Bridge	\$0	\$0	\$0
2				
3	Traffic Signal/Lighting	\$0	\$0	\$0
3				
3				
Total Estimated Construction Costs		\$0	\$0	\$0
4	Indirect Costs & Contingency	\$0	\$0	\$0
5	Right-of-Way/Easement Costs	\$0	\$0	\$0
4	Professional Services	\$0	\$0	\$0
Total Project Costs		\$0	\$0	\$0

Category	COST ITEM				
	1 Roadway	2 Bridge	3 Traffic Signal/Lighting	4 Contingency Construction Costs	5 ROW
Capital Value (\$)	-	\$0	\$0	\$-	\$0
Remaining Life (%)-20yr	44%	84%	27%	44%	96%
Remaining Cap. Value	\$-	\$-	\$-	\$-	\$-

Note: Assume Expected Life of 30 Years. Analysis Period is 20 years.

BENEFIT 1: Travel Time Savings (VHT)					
YEAR	Annual VHT		Annualized Savings		Discounted Value (3.1%)
	2050 No Improvement	2050 Improvement	Improvement w/ VHT Savings	'00 cost per hour 26.00	
2030	47,975	40,986	6989	\$ 303,443.22	\$ 303,443.22
2031	51,675	42,823	8852	\$ 384,337.10	\$ 372,780.89
2032	55,375	44,660	10715	\$ 465,230.98	\$ 437,674.55
2033	59,076	46,497	12579	\$ 546,124.86	\$ 498,328.76
2034	62,776	48,334	14442	\$ 627,018.75	\$ 554,939.79
2035	66,476	50,171	16305	\$ 707,912.63	\$ 607,695.94
2036	70,176	52,008	18168	\$ 788,806.51	\$ 656,777.85
2037	73,876	53,845	20031	\$ 869,700.39	\$ 702,358.77
2038	77,576	55,682	21894	\$ 950,594.28	\$ 744,604.87
2039	81,276	57,519	23758	\$ 1,031,488.16	\$ 783,675.48
2040	84,977	59,356	25621	\$ 1,112,382.04	\$ 819,723.37
2041	88,677	61,193	27484	\$ 1,193,275.92	\$ 852,894.98
2042	92,377	63,030	29347	\$ 1,274,169.80	\$ 883,330.70
2043	96,077	64,867	31210	\$ 1,355,063.69	\$ 911,165.06
2044	99,777	66,704	33073	\$ 1,435,957.57	\$ 936,526.98
2045	103,477	68,541	34937	\$ 1,516,851.45	\$ 959,539.97
2046	107,177	70,378	36800	\$ 1,597,745.33	\$ 980,322.37
2047	110,878	72,215	38663	\$ 1,678,639.22	\$ 998,987.50
2048	114,578	74,052	40526	\$ 1,759,533.10	\$ 1,015,643.90
2049	81,276	57,519	23758	\$ 1,031,488.16	\$ 577,496.83
2050	84,977	59,356	25621	\$ 1,112,382.04	\$ 604,060.81
2051	125,678	79,562	46116	\$ 2,002,214.74	\$ 1,054,577.94
TOTAL				\$ 23,744,360	\$ 16,256,551

COST 1: Roadways/Interchange Construction		
YEAR	CHANGE with Improvement	Discounted Value (3.1%)
2030	\$ -	\$ -
2031	\$ -	\$ -
2032	\$ -	\$ -
2033	\$ -	\$ -
2034	\$ -	\$ -
2035	\$ -	\$ -
2036	\$ -	\$ -
2037	\$ -	\$ -
2038	\$ -	\$ -
2039	\$ -	\$ -
2040	\$ -	\$ -
2041	\$ -	\$ -
2042	\$ -	\$ -
2043	\$ -	\$ -
2044	\$ -	\$ -
2045	\$ -	\$ -
2046	\$ -	\$ -
2047	\$ -	\$ -
2048	\$ -	\$ -
2049	\$ -	\$ -
2050	\$ -	\$ -
2051	\$ -	\$ -
TOTAL	\$ -	\$ -

COST 2: Bridge		
YEAR	CHANGE with Improvement	Discounted Value (3.1%)
2030	\$ -	\$ -
2031	\$ -	\$ -
2032	\$ -	\$ -
2033	\$ -	\$ -
2034	\$ -	\$ -
2035	\$ -	\$ -
2036	\$ -	\$ -
2037	\$ -	\$ -
2038	\$ -	\$ -
2039	\$ -	\$ -
2040	\$ -	\$ -
2041	\$ -	\$ -
2042	\$ -	\$ -
2043	\$ -	\$ -
2044	\$ -	\$ -
2045	\$ -	\$ -
2046	\$ -	\$ -
2047	\$ -	\$ -
2048	\$ -	\$ -
2049	\$ -	\$ -
2050	\$ -	\$ -
2051	\$ -	\$ -
TOTAL	\$ -	\$ -

Note: Trucks on average account for approximately 6% of network traffic. Passenger vehicle occupancy assumed to be 1.68.

MnDOT Office of Investment Management, Benefit Cost Analysis Trucks (Value of Time) \$ 39.30

Standard Values, Appendix A, Fiscal Year 2022

COST 3: Maintenance & Operation			COST 4: Contingency Construction Costs			COST 5: Right of Way (ROW)		
YEAR	CHANGE with Improvement	Discounted Value (3.1%)	YEAR	CHANGE with Improvement	Discounted Value (3.1%)	YEAR	CHANGE with Improvement	Discounted Value (3.1%)
2030	\$ (600,000)	(600,000)	2030	\$ -	-	2030	\$ -	-
2031	\$ (2,500)	(2,425)	2031	\$ -	-	2031	\$ -	-
2032	\$ (2,500)	(2,352)	2032	\$ -	-	2032	\$ -	-
2033	\$ (2,500)	(2,281)	2033	\$ -	-	2033	\$ -	-
2034	\$ (2,500)	(2,213)	2034	\$ -	-	2034	\$ -	-
2035	\$ (2,500)	(2,146)	2035	\$ -	-	2035	\$ -	-
2036	\$ (2,500)	(2,082)	2036	\$ -	-	2036	\$ -	-
2037	\$ (2,500)	(2,019)	2037	\$ -	-	2037	\$ -	-
2038	\$ (2,500)	(1,958)	2038	\$ -	-	2038	\$ -	-
2039	\$ (2,500)	(1,899)	2039	\$ -	-	2039	\$ -	-
2040	\$ (2,500)	(1,842)	2040	\$ -	-	2040	\$ -	-
2041	\$ (2,500)	(1,787)	2041	\$ -	-	2041	\$ -	-
2042	\$ (2,500)	(1,733)	2042	\$ -	-	2042	\$ -	-
2043	\$ (2,500)	(1,681)	2043	\$ -	-	2043	\$ -	-
2044	\$ (2,500)	(1,630)	2044	\$ -	-	2044	\$ -	-
2045	\$ (2,500)	(1,581)	2045	\$ -	-	2045	\$ -	-
2046	\$ (2,500)	(1,534)	2046	\$ -	-	2046	\$ -	-
2047	\$ (2,500)	(1,488)	2047	\$ -	-	2047	\$ -	-
2048	\$ (2,500)	(1,443)	2048	\$ -	-	2048	\$ -	-
2049	\$ (2,500)	(1,400)	2049	\$ -	-	2049	\$ -	-
2050	\$ (2,500)	(1,358)	2050	\$ -	-	2050	\$ -	-
2051	\$ (2,500)	(1,317)	2051	\$ -	-	2051	\$ -	-
TOTAL	\$ (652,500)	(638,169)	TOTAL	\$ -	\$ -	TOTAL	\$ -	\$ -

Note: Assume maintenance and operation costs of the Traffic Signal to be -2500 per year.

Remaining Capital Value		
YEAR	Remaining Capital Value	Discounted Value (3.1%)
2030	\$ -	\$ -
2031	\$ -	\$ -
2032	\$ -	\$ -
2033	\$ -	\$ -
2034	\$ -	\$ -
2035	\$ -	\$ -
2036	\$ -	\$ -
2037	\$ -	\$ -
2038	\$ -	\$ -
2039	\$ -	\$ -
2040	\$ -	\$ -
2041	\$ -	\$ -
2042	\$ -	\$ -
2043	\$ -	\$ -
2044	\$ -	\$ -
2045	\$ -	\$ -
2046	\$ -	\$ -
2047	\$ -	\$ -
2048	\$ -	\$ -
2049	\$ -	\$ -
2050	\$ -	\$ -
2051	\$ -	\$ -
TOTAL	\$ -	\$ -

US 169 & MN 210 (W JCT) --- Benefit / Cost Analysis for Alternative 3 Mini Roundabout 2050 Forecast

BASE 2030	Total
DELAY (Stop)	47,975

2050 No Improvement	Total	2030 No Improvement	Total
DELAY (Stop)	125,678	DELAY (Stop)	47,975

2050 Improvement	Total	2030 Improvement	Total
DELAY (Alt)	7,408	DELAY (Alt)	4,274

2050 Changes:	Total
DELAY	(118,270) -94.1%

Category	COST ITEM				
	1	2	3	4	5
	Roadway	Bridge	Traffic Signal/ Lighting	Contingency Construction Costs	ROW
Capital Value (\$)	630,300	\$0	\$103,000	\$ 293,320	\$0
Remaining Life (%)-20yr	44%	84%	27%	44%	96%
Remaining Cap. Value	\$ 277,332	\$ -	\$ 27,810	\$ 129,061	\$ -

Note: Assume Expected Life of 30 Years. Analysis Period is 20 years.

B/C Analysis Summary	
BENEFITS	Value(Discounted)
1. Travel Time Savings:	\$ 52,440,180
TOTAL	\$ 52,440,180

COSTS		Value(Discounted)
1. Roadway/Interchange	\$	(630,300)
2. Bridges	\$	-
3. Maintenance	\$	(157,963)
4. Contingency Costs	\$	(293,320)
5. Right-of-way (ROW)	\$	-
Remaining Capital	\$	228,697
TOTAL	\$	(852,886)

Benefit/Cost Analysis Results	
20-Yr Operation Benefit	\$ 52,440,180
20-Yr Safety Benefit	\$ 5,134,058
COSTS	\$ 852,886
B/C Ratio*	67.505

Category	Improvement Description	Estimated	Estimated	Estimated
		NA	NA	NA
1	Roadway Paving	\$448,300	\$0	\$0
1	Drainage and Erosion	\$74,000	\$0	\$0
1	Misc	\$108,000	\$0	\$0
2	Bridge	\$0	\$0	\$0
2				
3	Traffic Signal/Lighting	\$103,000	\$0	\$0
3				
3				
Total Estimated Construction Costs		\$733,300	\$0	\$0
4	Indirect Costs & Contingency	\$219,990	\$0	\$0
5	Right-of-Way/Easement Costs	\$0	\$0	\$0
4	Professional Services	\$73,330	\$0	\$0
Total Project Costs		\$1,026,620	\$0	\$0

YEAR	Annual VHT		Annualized Savings		Discounted Value (3.1%)
	2050 No Improvement	2050 Improvement	Improvement w/ VHT Savings	'00 cost per hour 26.00	
2030	47,975	4,274	43701	\$ 1,897,359.40	\$ 1,897,359.40
2031	51,675	4,424	47252	\$ 2,051,531.29	\$ 1,989,846.06
2032	55,375	4,573	50803	\$ 2,205,703.17	\$ 2,075,055.60
2033	59,076	4,722	54353	\$ 2,359,875.05	\$ 2,153,342.01
2034	62,776	4,871	57904	\$ 2,514,046.94	\$ 2,225,044.60
2035	66,476	5,020	61455	\$ 2,668,218.82	\$ 2,290,488.51
2036	70,176	5,170	65006	\$ 2,822,390.71	\$ 2,349,985.28
2037	73,876	5,319	68557	\$ 2,976,562.59	\$ 2,403,833.38
2038	77,576	5,468	72108	\$ 3,130,734.47	\$ 2,452,318.72
2039	81,276	5,617	75659	\$ 3,284,906.36	\$ 2,495,715.10
2040	84,977	5,766	79210	\$ 3,439,078.24	\$ 2,534,284.71
2041	88,677	5,916	82761	\$ 3,593,250.12	\$ 2,568,278.59
2042	92,377	6,065	86312	\$ 3,747,422.01	\$ 2,597,937.02
2043	96,077	6,214	89863	\$ 3,901,593.89	\$ 2,623,490.00
2044	99,777	6,363	93414	\$ 4,055,765.77	\$ 2,645,157.60
2045	103,477	6,513	96965	\$ 4,209,937.66	\$ 2,663,150.35
2046	107,177	6,662	100516	\$ 4,364,109.54	\$ 2,677,669.66
2047	110,878	6,811	104067	\$ 4,518,281.42	\$ 2,688,908.15
2048	114,578	6,960	107618	\$ 4,672,453.31	\$ 2,697,049.98
2049	81,276	5,617	75659	\$ 3,284,906.36	\$ 1,839,112.74
2050	84,977	5,766	79210	\$ 3,439,078.24	\$ 1,867,535.00
2051	125,678	7,408	118270	\$ 5,134,968.96	\$ 2,704,617.49
TOTAL				\$ 74,272,174	\$ 52,440,180

COST 1: Roadways/Interchange Construction		
YEAR	CHANGE with Improvement	Discounted Value (3.1%)
2030	\$(630,300)	\$(630,300)
2031	\$-	\$-
2032	\$-	\$-
2033	\$-	\$-
2034	\$-	\$-
2035	\$-	\$-
2036	\$-	\$-
2037	\$-	\$-
2038	\$-	\$-
2039	\$-	\$-
2040	\$-	\$-
2041	\$-	\$-
2042	\$-	\$-
2043	\$-	\$-
2044	\$-	\$-
2045	\$-	\$-
2046	\$-	\$-
2047	\$-	\$-
2048	\$-	\$-
2049	\$-	\$-
2050	\$-	\$-
2051	\$-	\$-
TOTAL	\$ (630,300)	\$ (630,300)

COST 2: Bridge		
YEAR	CHANGE with Improvement	Discounted Value (3.1%)
2030	\$-	\$-
2031	\$-	\$-
2032	\$-	\$-
2033	\$-	\$-
2034	\$-	\$-
2035	\$-	\$-
2036	\$-	\$-
2037	\$-	\$-
2038	\$-	\$-
2039	\$-	\$-
2040	\$-	\$-
2041	\$-	\$-
2042	\$-	\$-
2043	\$-	\$-
2044	\$-	\$-
2045	\$-	\$-
2046	\$-	\$-
2047	\$-	\$-
2048	\$-	\$-
2049	\$-	\$-
2050	\$-	\$-
2051	\$-	\$-
TOTAL	\$ -	\$ -

Note: Trucks on average account for approximately 6% of network traffic. Passenger vehicle occupancy assumed to be 1.68.

MnDOT Office of Investment Management, Benefit Cost Analysis Trucks (Value of Time) \$ 39.30
Standard Values, Appendix A, Fiscal Year 2022

COST 3: Maintenance & Operation			COST 4: Contingency Construction Costs			COST 5: Right of Way (ROW)		
YEAR	CHANGE with Improvement	Discounted Value (3.1%)	YEAR	CHANGE with Improvement	Discounted Value (3.1%)	YEAR	CHANGE with Improvement	Discounted Value (3.1%)
2030	\$(103,000)	\$(103,000)	2030	\$(293,320)	\$(293,320)	2030	\$-	\$-
2031	\$(3,600)	\$(3,492)	2031	\$-	\$-	2031	\$-	\$-
2032	\$(3,600)	\$(3,387)	2032	\$-	\$-	2032	\$-	\$-
2033	\$(3,600)	\$(3,285)	2033	\$-	\$-	2033	\$-	\$-
2034	\$(3,600)	\$(3,186)	2034	\$-	\$-	2034	\$-	\$-
2035	\$(3,600)	\$(3,090)	2035	\$-	\$-	2035	\$-	\$-
2036	\$(3,600)	\$(2,997)	2036	\$-	\$-	2036	\$-	\$-
2037	\$(3,600)	\$(2,907)	2037	\$-	\$-	2037	\$-	\$-
2038	\$(3,600)	\$(2,820)	2038	\$-	\$-	2038	\$-	\$-
2039	\$(3,600)	\$(2,735)	2039	\$-	\$-	2039	\$-	\$-
2040	\$(3,600)	\$(2,653)	2040	\$-	\$-	2040	\$-	\$-
2041	\$(3,600)	\$(2,573)	2041	\$-	\$-	2041	\$-	\$-
2042	\$(3,600)	\$(2,496)	2042	\$-	\$-	2042	\$-	\$-
2043	\$(3,600)	\$(2,421)	2043	\$-	\$-	2043	\$-	\$-
2044	\$(3,600)	\$(2,348)	2044	\$-	\$-	2044	\$-	\$-
2045	\$(3,600)	\$(2,277)	2045	\$-	\$-	2045	\$-	\$-
2046	\$(3,600)	\$(2,209)	2046	\$-	\$-	2046	\$-	\$-
2047	\$(3,600)	\$(2,142)	2047	\$-	\$-	2047	\$-	\$-
2048	\$(3,600)	\$(2,078)	2048	\$-	\$-	2048	\$-	\$-
2049	\$(3,600)	\$(2,016)	2049	\$-	\$-	2049	\$-	\$-
2050	\$(3,600)	\$(1,955)	2050	\$-	\$-	2050	\$-	\$-
2051	\$(3,600)	\$(1,896)	2051	\$-	\$-	2051	\$-	\$-
TOTAL	\$ (178,600)	\$ (157,963)	TOTAL	\$ (293,320)	\$ (293,320)	TOTAL	\$ -	\$ -

Note: Assume maintenance and operation costs of the Roundabout to be -3600 per year.

Remaining Capital Value		
YEAR	Remaining Capital Value	Discounted Value (3.1%)
2030	\$-	\$-
2031	\$-	\$-
2032	\$-	\$-
2033	\$-	\$-
2034	\$-	\$-
2035	\$-	\$-
2036	\$-	\$-
2037	\$-	\$-
2038	\$-	\$-
2039	\$-	\$-
2040	\$-	\$-
2041	\$-	\$-
2042	\$-	\$-
2043	\$-	\$-
2044	\$-	\$-
2045	\$-	\$-
2046	\$-	\$-
2047	\$-	\$-
2048	\$-	\$-
2049	\$-	\$-
2050	\$-	\$-
2051	\$434,203	\$228,697
TOTAL	\$ 434,203	\$ 228,697

US 169 & MN 210 (W JCT)

Alternative 3 Mini Roundabout
(Assume Install in 2030)

ALTERNATIVE COST ESTIMATE - 7/1/2021

	Concept Layout: Roundabout
	Estimated Costs
Bridge	\$0
Roadway Paving / Construction	\$448,300
Drainage and Erosion	\$74,000
Traffic Signal/Lighting	\$103,000
Misc	\$108,000
Total Estimated Construction Costs	\$733,300
Indirect Costs & Contingency	\$219,990
Right-of-Way/Easement Costs	\$0
Professional Services	\$73,330
Total Project Costs	\$1,310,256

Notes:

US 169 & MN 210 (W JCT) --- Benefit / Cost Analysis for Alternative 4 Truck Route 2050 Forecast

BASE 2030	Total
DELAY (Stop)	47,975

2050 No Improvement	Total	2030 No Improvement	Total
DELAY (Stop)	125,678	DELAY (Stop)	47,975

2050 Improvement	Total	2030 Improvement	Total
DELAY (Alt)	102,267	DELAY (Alt)	42,021

2050 Changes:	Total
DELAY	(23,411) -18.6%

Category	COST ITEM				
	1	2	3	4	5
	Roadway	Bridge	Traffic Signal/ Lighting	Contingency Construction Costs	ROW
Capital Value (\$)	-	\$0	\$0	-	\$0
Remaining Life (%) - 20yr	44%	84%	27%	44%	96%
Remaining Cap. Value	\$ -	\$ -	\$ -	\$ -	\$ -

Note: Assume Expected Life of 30 Years. Analysis Period is 20 years.

B/C Analysis Summary	
BENEFITS	Value(Discounted)
1. Travel Time Savings:	\$ 9,255,800
TOTAL	\$ 9,255,800

COSTS		Value(Discounted)
1. Roadway/Interchange	\$	-
2. Bridges	\$	-
3. Maintenance	\$	-
4. Contingency Costs	\$	-
5. Right-of-way (ROW)	\$	-
Remaining Capital	\$	-
TOTAL	\$	-

Benefit/Cost Analysis Results	
20-Yr Operation Benefit	\$ 9,255,800
20-Yr Safety Benefit	\$ 180,034
COSTS	\$ 10,000
B/C Ratio*	943.583

Category	Improvement Description	Estimated	Estimated	Estimated
		NA	NA	NA
1	Roadway Paving	\$0	\$0	\$0
1	Drainage and Erosion	\$0	\$0	\$0
1	Misc	\$0	\$0	\$0
2	Bridges	\$0	\$0	\$0
2				
3	Traffic Signal/Lighting	\$0	\$0	\$0
3				
3				
Total Estimated Construction Costs		\$0	\$0	\$0
4	Indirect Costs & Contingency	\$0	\$0	\$0
5	Right-of-Way/Easement Costs	\$0	\$0	\$0
4	Professional Services	\$0	\$0	\$0
Total Project Costs		\$0	\$0	\$0

YEAR	Annual VHT		Annualized Savings		Discounted Value (3.1%)
	2050 No Improvement	2050 Improvement	Improvement w/ VHT Savings	'00 cost per hour 26.00	
2030	47,975	42,021	5954	\$ 258,493.96	\$ 258,493.96
2031	51,675	44,890	6785	\$ 294,586.16	\$ 285,728.58
2032	55,375	47,759	7616	\$ 330,678.37	\$ 311,091.72
2033	59,076	50,628	8448	\$ 366,770.58	\$ 334,671.32
2034	62,776	53,497	9279	\$ 402,862.79	\$ 356,551.68
2035	66,476	56,366	10110	\$ 438,954.99	\$ 376,813.69
2036	70,176	59,234	10941	\$ 475,047.20	\$ 395,534.87
2037	73,876	62,103	11773	\$ 511,139.41	\$ 412,789.56
2038	77,576	64,972	12604	\$ 547,231.62	\$ 428,649.04
2039	81,276	67,841	13435	\$ 583,323.82	\$ 443,181.61
2040	84,977	70,710	14267	\$ 619,416.03	\$ 456,452.71
2041	88,677	73,579	15098	\$ 655,508.24	\$ 468,525.07
2042	92,377	76,448	15929	\$ 691,600.45	\$ 479,458.79
2043	96,077	79,316	16760	\$ 727,692.65	\$ 489,311.41
2044	99,777	82,185	17592	\$ 763,784.86	\$ 498,138.07
2045	103,477	85,054	18423	\$ 799,877.07	\$ 505,991.55
2046	107,177	87,923	19254	\$ 835,969.28	\$ 512,922.41
2047	110,878	90,792	20086	\$ 872,061.48	\$ 518,979.01
2048	114,578	93,661	20917	\$ 908,153.69	\$ 524,207.68
2049	81,276	67,841	13435	\$ 583,323.82	\$ 326,584.13
2050	84,977	70,710	14267	\$ 619,416.03	\$ 336,363.71
2051	125,678	102,267	23411	\$ 1,016,430.31	\$ 535,359.65
TOTAL				\$ 13,302,323	\$ 9,255,800

COST 1: Roadways/Interchange Construction		
YEAR	CHANGE with Improvement	Discounted Value (3.1%)
2030	\$ -	\$ -
2031	\$ -	\$ -
2032	\$ -	\$ -
2033	\$ -	\$ -
2034	\$ -	\$ -
2035	\$ -	\$ -
2036	\$ -	\$ -
2037	\$ -	\$ -
2038	\$ -	\$ -
2039	\$ -	\$ -
2040	\$ -	\$ -
2041	\$ -	\$ -
2042	\$ -	\$ -
2043	\$ -	\$ -
2044	\$ -	\$ -
2045	\$ -	\$ -
2046	\$ -	\$ -
2047	\$ -	\$ -
2048	\$ -	\$ -
2049	\$ -	\$ -
2050	\$ -	\$ -
2051	\$ -	\$ -
TOTAL	\$ -	\$ -

COST 2: Bridge		
YEAR	CHANGE with Improvement	Discounted Value (3.1%)
2030	\$ -	\$ -
2031	\$ -	\$ -
2032	\$ -	\$ -
2033	\$ -	\$ -
2034	\$ -	\$ -
2035	\$ -	\$ -
2036	\$ -	\$ -
2037	\$ -	\$ -
2038	\$ -	\$ -
2039	\$ -	\$ -
2040	\$ -	\$ -
2041	\$ -	\$ -
2042	\$ -	\$ -
2043	\$ -	\$ -
2044	\$ -	\$ -
2045	\$ -	\$ -
2046	\$ -	\$ -
2047	\$ -	\$ -
2048	\$ -	\$ -
2049	\$ -	\$ -
2050	\$ -	\$ -
2051	\$ -	\$ -
TOTAL	\$ -	\$ -

Note: Trucks on average account for approximately 6% of network traffic. Passenger vehicle occupancy assumed to be 1.68.

MnDOT Office of Investment Management, Benefit Cost Analysis Trucks (Value of Time) \$ 39.30

Standard Values, Appendix A, Fiscal Year 2022

COST 3: Maintenance & Operation			COST 4: Contingency Construction Costs			COST 5: Right of Way (ROW)		
YEAR	CHANGE with Improvement	Discounted Value (3.1%)	YEAR	CHANGE with Improvement	Discounted Value (3.1%)	YEAR	CHANGE with Improvement	Discounted Value (3.1%)
2030	\$ -	\$ -	2030	\$ -	\$ -	2030	\$ -	\$ -
2031	\$ -	\$ -	2031	\$ -	\$ -	2031	\$ -	\$ -
2032	\$ -	\$ -	2032	\$ -	\$ -	2032	\$ -	\$ -
2033	\$ -	\$ -	2033	\$ -	\$ -	2033	\$ -	\$ -
2034	\$ -	\$ -	2034	\$ -	\$ -	2034	\$ -	\$ -
2035	\$ -	\$ -	2035	\$ -	\$ -	2035	\$ -	\$ -
2036	\$ -	\$ -	2036	\$ -	\$ -	2036	\$ -	\$ -
2037	\$ -	\$ -	2037	\$ -	\$ -	2037	\$ -	\$ -
2038	\$ -	\$ -	2038	\$ -	\$ -	2038	\$ -	\$ -
2039	\$ -	\$ -	2039	\$ -	\$ -	2039	\$ -	\$ -
2040	\$ -	\$ -	2040	\$ -	\$ -	2040	\$ -	\$ -
2041	\$ -	\$ -	2041	\$ -	\$ -	2041	\$ -	\$ -
2042	\$ -	\$ -	2042	\$ -	\$ -	2042	\$ -	\$ -
2043	\$ -	\$ -	2043	\$ -	\$ -	2043	\$ -	\$ -
2044	\$ -	\$ -	2044	\$ -	\$ -	2044	\$ -	\$ -
2045	\$ -	\$ -	2045	\$ -	\$ -	2045	\$ -	\$ -
2046	\$ -	\$ -	2046	\$ -	\$ -	2046	\$ -	\$ -
2047	\$ -	\$ -	2047	\$ -	\$ -	2047	\$ -	\$ -
2048	\$ -	\$ -	2048	\$ -	\$ -	2048	\$ -	\$ -
2049	\$ -	\$ -	2049	\$ -	\$ -	2049	\$ -	\$ -
2050	\$ -	\$ -	2050	\$ -	\$ -	2050	\$ -	\$ -
2051	\$ -	\$ -	2051	\$ -	\$ -	2051	\$ -	\$ -
TOTAL	\$ -	\$ -	TOTAL	\$ -	\$ -	TOTAL	\$ -	\$ -

Note: Assume maintenance and operation costs of the Traffic Signal to be per year.

Remaining Capital Value		
YEAR	Remaining Capital Value	Discounted Value (3.1%)
2030	\$ -	\$ -
2031	\$ -	\$ -
2032	\$ -	\$ -
2033	\$ -	\$ -
2034	\$ -	\$ -
2035	\$ -	\$ -
2036	\$ -	\$ -
2037	\$ -	\$ -
2038	\$ -	\$ -
2039	\$ -	\$ -
2040	\$ -	\$ -
2041	\$ -	\$ -
2042	\$ -	\$ -
2043	\$ -	\$ -
2044	\$ -	\$ -
2045	\$ -	\$ -
2046	\$ -	\$ -
2047	\$ -	\$ -
2048	\$ -	\$ -
2049	\$ -	\$ -
2050	\$ -	\$ -
2051	\$ -	\$ -
TOTAL	\$ -	\$ -